

A1. 主体関係 / Machine body / Maschinengehäuse /  
 Corps de la machine / Cuerpo de la máquina

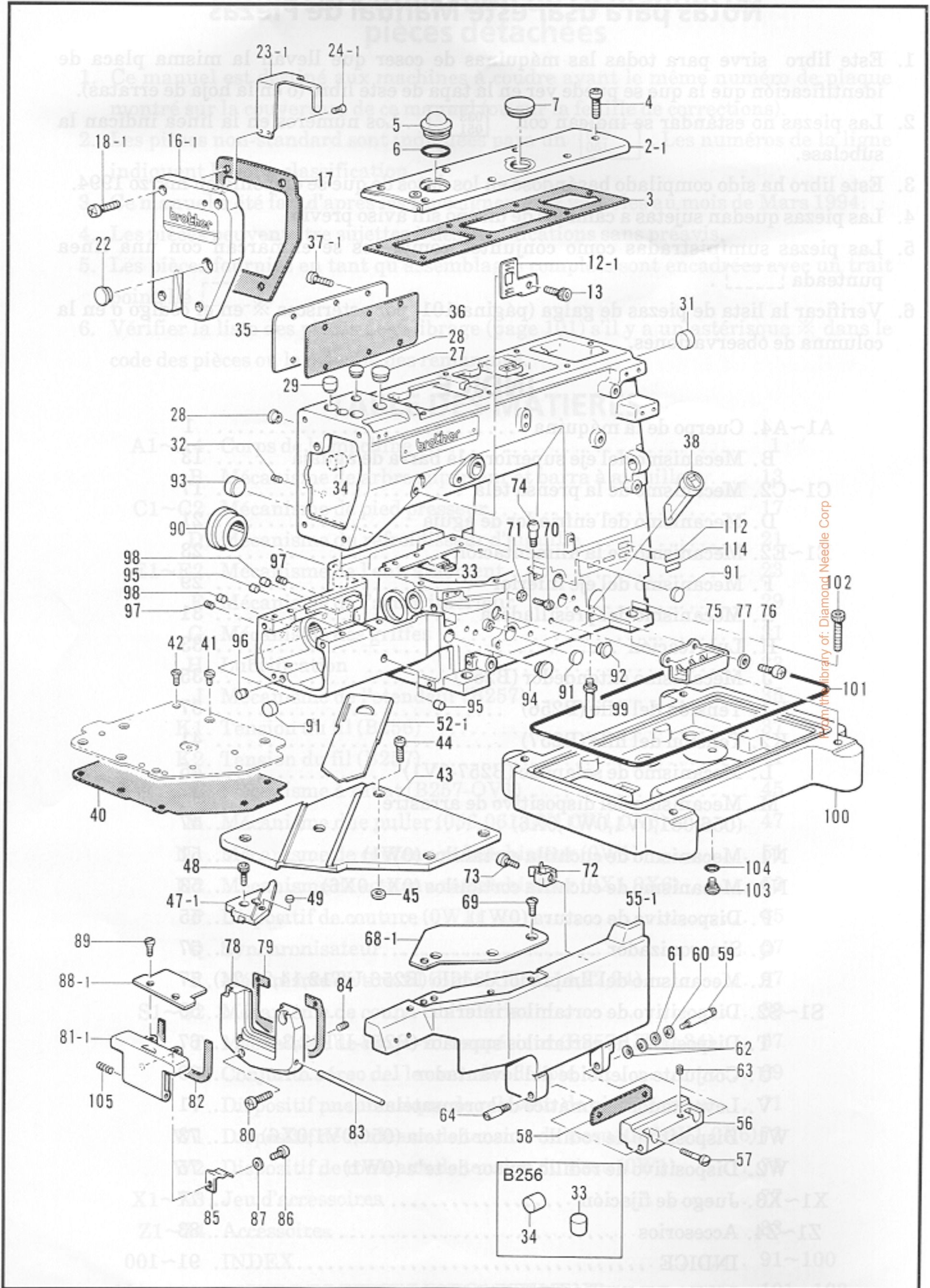

A1. 主体関係 / Machine body / Maschinengehäuse /  
Corps de la machine / Cuerpo de la máquina

| REF.NO. | CODE      | Q'TY | ヒンメイ           | NAME OF PARTS                 | RM |
|---------|-----------|------|----------------|-------------------------------|----|
| 2-1     | S08627001 | 1    | ウフフタ           | TOP COVER                     |    |
| 3       | S08628000 | 1    | ウフフタバツキン       | TOP COVER PACKING             |    |
| 4       | 062681012 | 7    | ナベコ437-40X10   | SCREW, PAN M4.37-40X10        |    |
| 5       | S02606000 | 1    | ユリヨウケイマド       | OIL GAUGE WINDOW              |    |
| 6       | 081014670 | 1    | リングPW14        | O RING, PW14                  |    |
| 7       | 159150009 | 1    | カマジクメクラセン      | OIL CAP                       |    |
| 12-1    | S08629009 | 1    | ハリイトクリカバー      | NEEDLE THREAD TAKE-UP COVER   |    |
| 13      | 018060822 | 1    | アナボルト6X8       | BOLT, SOCKET M6X8             |    |
| 16-1    | S08630201 | 1    | メンイタ           | FACE PLATE                    |    |
| 17      | S08631000 | 1    | メンイタバツキン       | FACE PLATE PACKING            |    |
| 18-1    | 062681612 | 4    | ナベコ437-40X16   | SCREW, PAN M4.37-40X16        |    |
| 22      | 117934009 | 1    | メクラセン          | OIL CAP                       |    |
| 23-1    | S08632009 | 1    | ハリボウテンピンカバー    | NEEDLE BAR TAKE-UP COVER      |    |
| 24-1    | 102843004 | 2    | サラネジ3.57       | SCREW, FLAT M3.57             |    |
| 27      | 104449009 | 1    | メクラセン          | OIL CAP                       |    |
| 28      | 104450109 | 2    | メクラセン          | OIL CAP                       |    |
| 29      | 154841009 | 1    | メクラセン          | OIL CAP                       |    |
| 31      | S00313009 | 1    | メクラセン          | OIL CAP                       |    |
| 32      | 014060622 | 1    | アナトメネジ6X6クボミ   | SET SCREW, SOCKET (CP) M6X6   |    |
| 35      | S28007001 | 1    | ガワイタ           | REAR COVER                    |    |
| 36      | S28008000 | 1    | ガワイタバツキン       | REAR COVER PACKING            |    |
| 37-1    | 062680812 | 6    | ナベコ437-40X8    | SCREW, PAN M4.37-40X8         |    |
| 38      | 148084001 | 1    | オイルゲージマド       | OIL GAUGE WINDOW              |    |
| 40      | S28011000 | 1    | ベットウワカバーパツキン   | BED UPPER COVER PACKING       |    |
| 41      | 107407003 | 5    | シメネジ4.37       | SCREW, M4.37                  |    |
| 42      | 107272002 | 2    | サラネジ4.37       | SCREW, FLAT M4.37             |    |
| 43      | S28012001 | 1    | クロスプレートA       | CLOTH PLATE (A)               |    |
| 44      | 060681212 | 4    | バインド437-40X12  | SCREW, BIND M4.37-40X12       |    |
| 45      | S28014000 | 4    | クロスプレートパツキン    | CLOTH PLATE PACKING           |    |
| 47-1    | S28765001 | 1    | クロスプレートSA      | CLOTH PLATE (SA)              |    |
| 48      | 018681232 | 2    | アナボルト437-40X12 | BOLT, SOCKET M4.37-40X12      |    |
| 49      | S28820000 | 1    | ホジヨイタアテゴム      | SUPPORT PLATE RUBBER          |    |
| 52-1    | S28492001 | 1    | スベリイタE         | SLIDE PLATE (E)               |    |
| 55-1    | S28027001 | 1    | マエカバーA         | FRONT COVER (A)               |    |
| 56      | S28031001 | 1    | マエカバーササエ       | FRONT COVER SUPPORT           |    |
| 57      | 102424004 | 2    | シメネジ4.37       | SCREW, M4.37                  |    |
| 58      | S28157000 | 1    | マエカバーササエパツキン   | FRONT COVER SUPPORT PACKING   |    |
| 59      | S28032001 | 1    | マエカバーササエジクR    | FRONT COVER SUPPORT SHAFT (R) |    |
| 60      | 048040342 | 1    | トメワE4          | RETAINING RING, E4            |    |
| 61      | 025050132 | 1    | ヒラザガネシヨウ5      | WASHER, PLAIN S 5             |    |
| 62      | 146598001 | 2    | バネザガネ          | WASHER, SPRING                |    |
| 63      | 014680622 | 1    | アナトメネジ4.37クボミ  | SET SCREW, SOCKET (CP) M4.37  |    |
| 64      | S28033000 | 1    | マエカバーササエジクL    | FRONT COVER SUPPORT SHAFT (L) |    |
| 68-1    | S28814001 | 1    | ホジヨイタB         | SUPPORT PLATE (B)             |    |
| 69      | 107231002 | 3    | サラネジ4.76       | SCREW, FLAT M4.76             |    |
| 70      | 154574001 | 1    | ボルト4.37        | BOLT, M4.37                   |    |
| 71      | 105234003 | 1    | ナツト4.37        | NUT, M4.37                    |    |
| 72      | S28034101 | 1    | カバートメバネ        | COVER SET SPRING              |    |
| 73      | 062710612 | 1    | ナベコ476-32X6    | SCREW, PAN M4.76-32X6         |    |
| 74      | S28035001 | 1    | バネウケネジ         | SCREW                         |    |
| 75      | S28812000 | 1    | シタイトテンピンカバー    | LOOPER THREAD TAKE-UP COVER   |    |
| 76      | 062680812 | 2    | ナベコ437-40X8    | SCREW, PAN M4.37-40X8         |    |
| 77      | 100645003 | 2    | ザガネ            | WASHER                        |    |
| 78      | S28036001 | 1    | ヨコカバーササエA      | SIDE COVER SUPPORT (A)        |    |
| 79      | S28037000 | 1    | ヨコカバーササエパツキン   | SIDE COVER SUPPORT PACKING    |    |
| 80      | 062681612 | 3    | ナベコ437-40X16   | SCREW, PAN M4.37-40X16        |    |
| 81-1    | S28038001 | 1    | ヨコカバーA         | SIDE COVER (A)                |    |
| 82      | S28039000 | 1    | ヨコカバーパツキン      | SIDE COVER PACKING            |    |
| 83      | S28040000 | 1    | ヨコカバーササエジク     | SIDE COVER SUPPORT SHAFT      |    |

From the library of: Diamond Needle Corp

A1. 主体関係 / Machine body / Maschinengehäuse /  
 Corps de la machine / Cuerpo de la máquina

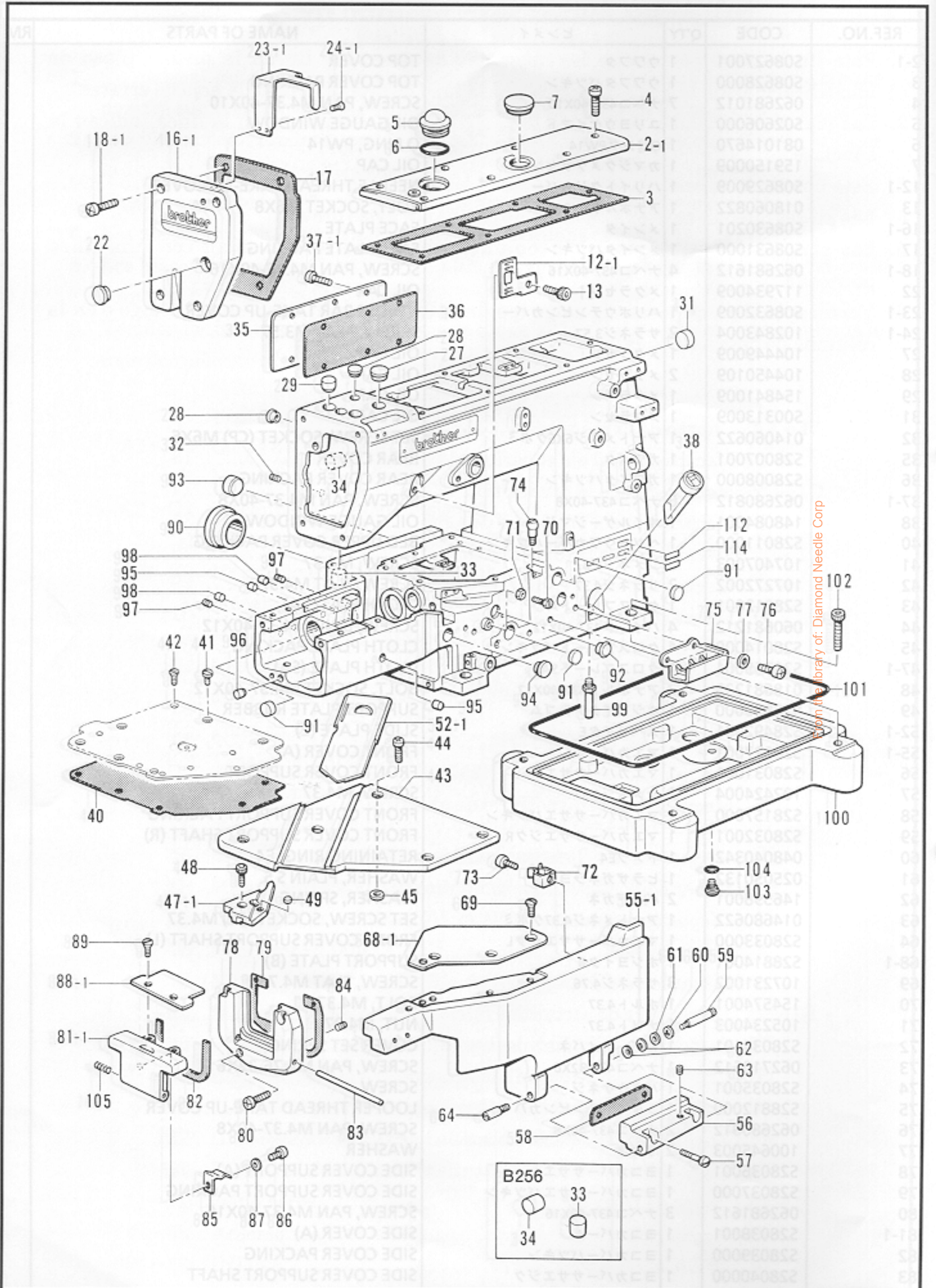

FROM THE LIBRARY OF: Diamond Needle Corp

A1. 主体関係 / Machine body / Maschinengehäuse /  
Corps de la machine / Cuerpo de la máquina

| REF.NO. | CODE      | Q'TY | ヒンメイ              | NAME OF PARTS                | RM |
|---------|-----------|------|-------------------|------------------------------|----|
| 84      | 148294001 | 2    | アナトメネジ3.57クボミ     | SET SCREW, SOCKET (CP) M3.57 |    |
| 85      | S28156001 | 1    | ヨコカバートメバネ         | SIDE COVER SET SPRING        |    |
| 86      | 062680712 | 1    | ナベコ437-40X7       | SCREW, PAN M4.37-40X7        |    |
| 87      | 100645003 | 1    | ザガネ               | WASHER                       |    |
| 88-1    | S28041001 | 1    | ヨコカバーウワイタA        | SIDE COVER UPPER PLATE (A)   |    |
| 89      | S01696002 | 2    | サラネジ3.57X6        | SCREW, FLAT M3.57X6          |    |
| 90      | S28043009 | 1    | メクラセン             | OIL CAP                      |    |
| 91      | S28044009 | 3    | メクラセン             | OIL CAP                      |    |
| 92      | 104449009 | 1    | メクラセン             | OIL CAP                      |    |
| 93      | 140066009 | 1    | メクラセン             | OIL CAP                      |    |
| 94      | 104450109 | 1    | メクラセン             | OIL CAP                      |    |
| 95      | 142274009 | 2    | メクラセン             | OIL CAP                      |    |
| 96      | 156217009 | 1    | メクラセン             | OIL CAP                      |    |
| 97      | 014060622 | 2    | アナトメネジ6X6クボミ      | SET SCREW, SOCKET (CP) M6X6  |    |
| 98      | 142274009 | 2    | メクラセン             | OIL CAP                      |    |
| 99      | 104830101 | 4    | キヤクチュウS           | BED LEG (S)                  |    |
| 100     | S28045000 | 1    | アブラウケ             | OIL RESERVOIR                |    |
| 101     | S28046000 | 1    | オリング              | O RING                       |    |
| 102     | 018081622 | 4    | アナボルト8X16         | BOLT, SOCKET M8X16           |    |
| 103     | 110641002 | 1    | ダンネジ9.52          | STUD SCREW, M9.52            |    |
| 104     | 109203001 | 1    | オリング              | O RING                       |    |
| 105     | S28850001 | 1    | ヨコカバーササエジクバネ      | SPRING                       |    |
| 112     | ※         | 1    | シヨウラベル            | LABEL                        |    |
| 114     | S10696027 | 1    | ソウチヒヨウジラベル (UT11) | DEVICE LABEL (UT11)          |    |
| 114     | S10696029 | 1    | ソウチヒヨウジラベル (UT13) | DEVICE LABEL (UT13)          |    |
| 114     | S10696033 | 1    | ソウチヒヨウジラベル (UT21) | DEVICE LABEL (UT21)          |    |
| 114     | S10696035 | 1    | ソウチヒヨウジラベル (UT23) | DEVICE LABEL (UT23)          |    |
|         |           |      | <B256>            |                              |    |
| 33      | 154841009 | 1    | メクラセン             | OIL CAP                      |    |
| 34      | 156887001 | 1    | メクラセン17           | OIL CAP 17                   |    |
| 114     | S10696028 | 1    | ソウチヒヨウジラベル (UT12) | DEVICE LABEL (UT12)          |    |
| 114     | S10696030 | 1    | ソウチヒヨウジラベル (UT14) | DEVICE LABEL (UT14)          |    |
| 114     | S10696034 | 1    | ソウチヒヨウジラベル (UT22) | DEVICE LABEL (UT22)          |    |
| 114     | S10696036 | 1    | ソウチヒヨウジラベル (UT24) | DEVICE LABEL (UT24)          |    |
|         |           |      | <B257>            |                              |    |
| 114     | S10696031 | 1    | ソウチヒヨウジラベル (UT32) | DEVICE LABEL (UT32)          |    |
| 114     | S10696032 | 1    | ソウチヒヨウジラベル (UT34) | DEVICE LABEL (UT34)          |    |
| 114     | S10696037 | 1    | ソウチヒヨウジラベル (UT42) | DEVICE LABEL (UT42)          |    |
| 114     | S10696038 | 1    | ソウチヒヨウジラベル (UT44) | DEVICE LABEL (UT44)          |    |
|         |           |      | <オプションパーツ>        | <OPTION PARTS>               |    |
| 114     | S10696039 | 1    | ソウチヒヨウジラベル (CS1)  | DEVICE LABEL (CS1)           |    |
|         |           |      | <033>             |                              |    |
| 128     | S28052001 | 1    | ガイドL              | GUIDE (L)                    |    |
| 129     | S28053001 | 1    | ガイドR              | GUIDE (R)                    |    |
| 130     | S10072001 | 2    | ネジ                | SCREW M4.75                  |    |

A2. 主体関係 / Machine body / Maschinengehäuse /  
 Corps de la machine / Cuerpo de la máquina

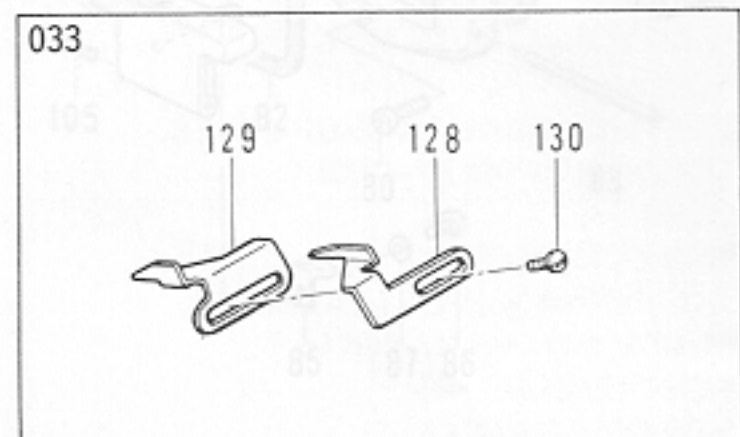
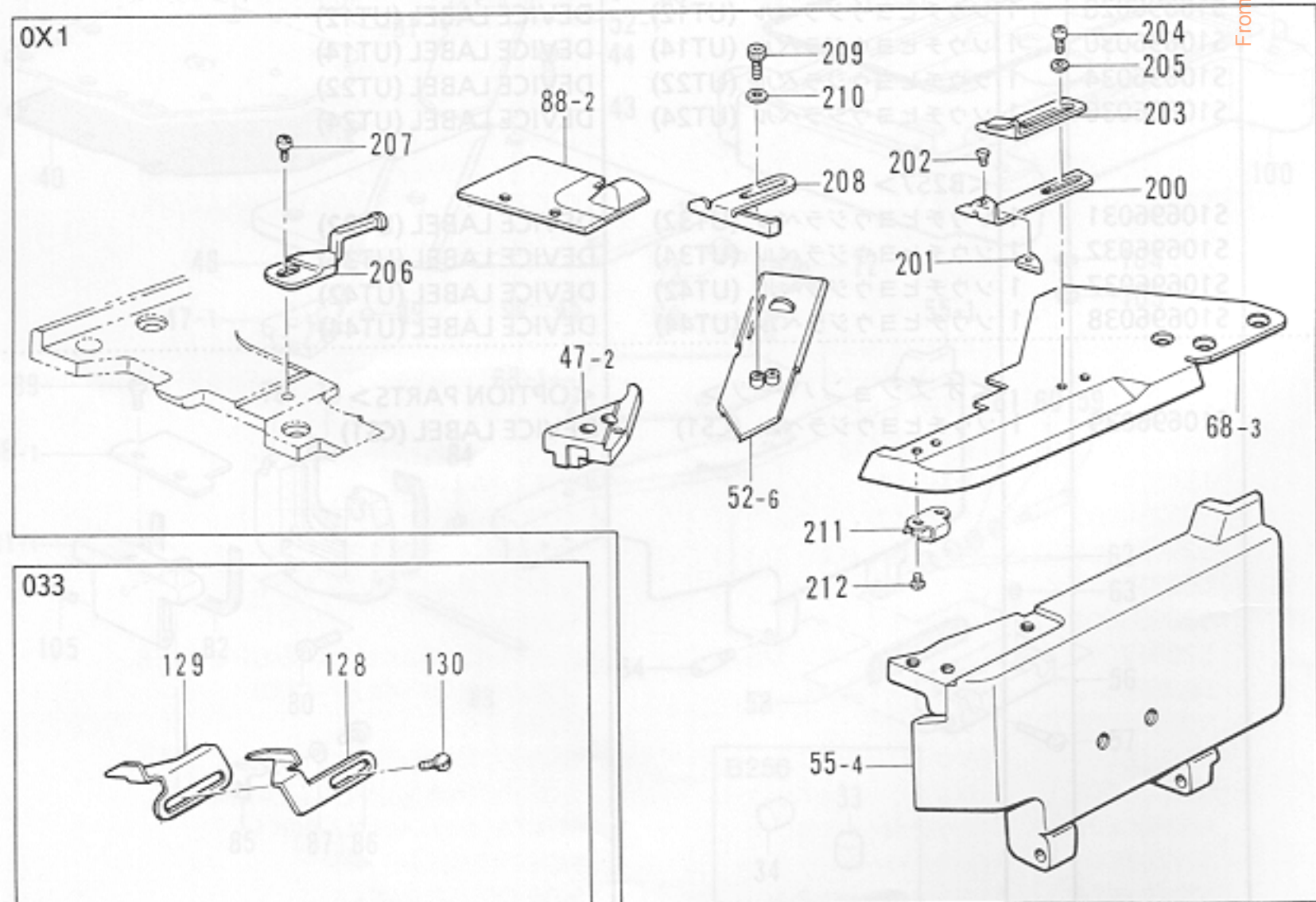
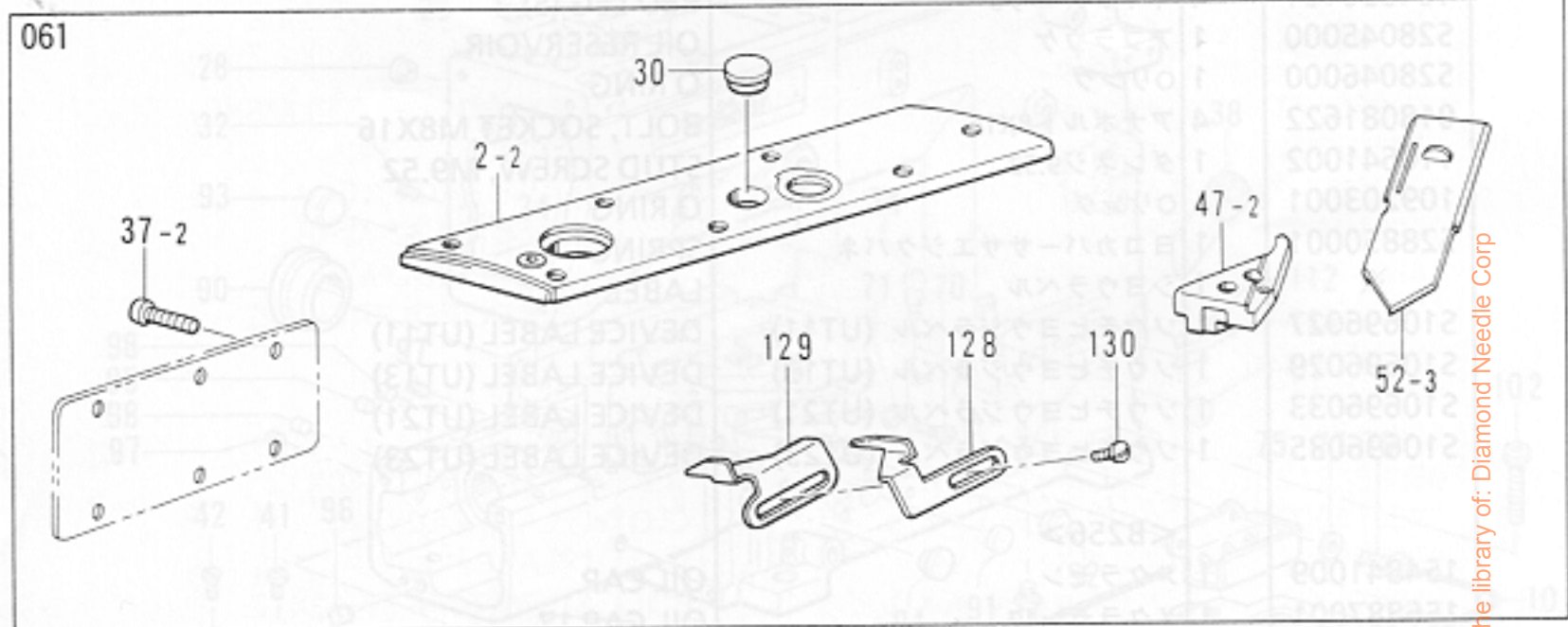
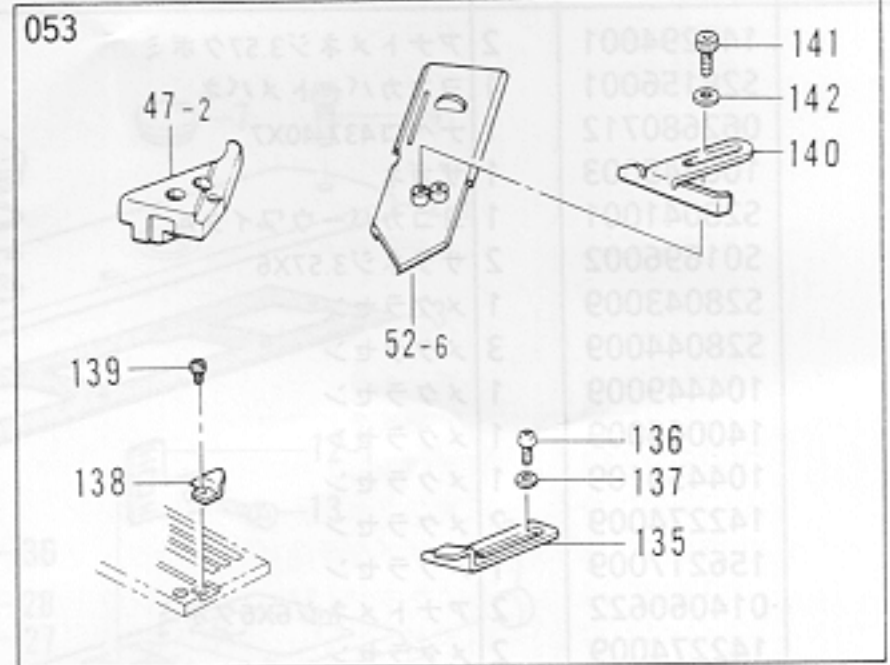
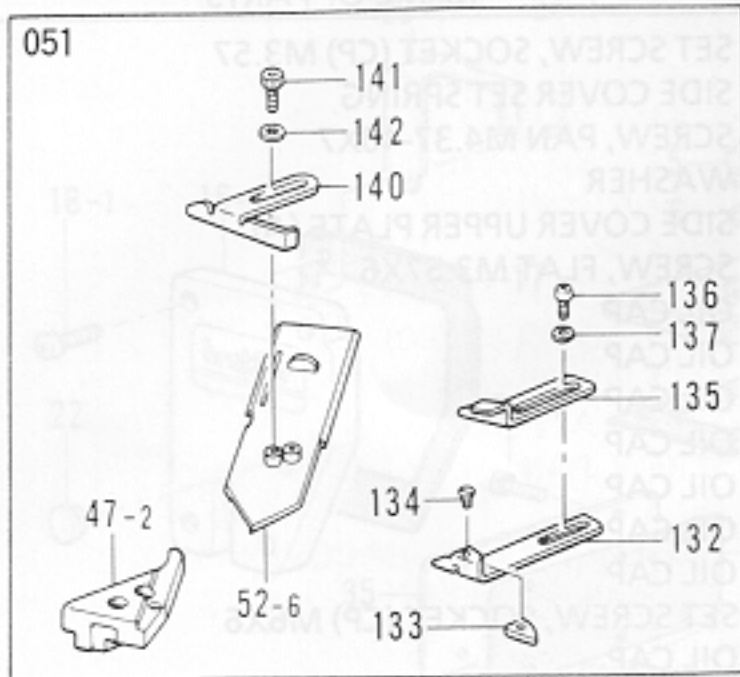

From the library of: Diamond Needle Corp

A2. 主体関係 / Machine body / Maschinengehäuse /  
Corps de la machine / Cuerpo de la máquina

| REF.NO. | CODE      | Q'TY | ヒンメイ         | NAME OF PARTS              | RM |
|---------|-----------|------|--------------|----------------------------|----|
|         |           |      | <051>        |                            |    |
| 47-2    | S28766001 | 1    | クロスプレートSB    | CLOTH PLATE (SB)           |    |
| 52-6    | S28024001 | 1    | スベリイタD       | SLIDE PLATE (D)            |    |
| 132     | S28054001 | 1    | ヘムヌイガイドL     | HEM SEWING GUIDE (L)       |    |
| 133     | S28055001 | 1    | ガイドチップ       | GUIDE TIP                  |    |
| 134     | 100360003 | 1    | サラネジ2.38     | SCREW, FLAT M2.38          |    |
| 135     | S28056001 | 1    | ヘムヌイガイドR     | HEM SEWING GUIDE (R)       |    |
| 136     | 062711212 | 2    | ナベコ476-32X12 | SCREW, PAN M4.76-32X12     |    |
| 137     | 113431002 | 2    | ザガネ          | WASHER                     |    |
| 140     | S28500001 | 1    | ヌノガイドRA      | CLOTH GUIDE (RA)           |    |
| 141     | 018680822 | 2    | アナボルト4.37X8  | BOLT, SOCKET M4.37X8       |    |
| 142     | 100645003 | 2    | ザガネ          | WASHER                     |    |
|         |           |      | <053>        |                            |    |
| 47-2    | S28766001 | 1    | クロスプレートSB    | CLOTH PLATE (SB)           |    |
| 52-6    | S28024001 | 1    | スベリイタD       | SLIDE PLATE (D)            |    |
| 135     | S28056001 | 1    | ヘムヌイガイドR     | HEM SEWING GUIDE (R)       |    |
| 136     | 062711212 | 2    | ナベコ476-32X12 | SCREW, PAN M4.76-32X12     |    |
| 137     | 113431002 | 2    | ザガネ          | WASHER                     |    |
| 138     | S28822001 | 1    | ヘムヌイガイドS     | HEM SEWING GUIDE (S)       |    |
| 139     | S01295001 | 1    | シメネジ2.38X3.5 | SCREW, M2.38X3.5           |    |
| 140     | S28500001 | 1    | ヌノガイドRA      | CLOTH GUIDE (RA)           |    |
| 141     | 018680822 | 2    | アナボルト4.37X8  | BOLT, SOCKET M4.37X8       |    |
| 142     | 100645003 | 2    | ザガネ          | WASHER                     |    |
|         |           |      | <061>        |                            |    |
| 2-2     | S12703001 | 1    | ウワフタ         | TOP COVER                  |    |
| 30      | 159150009 | 1    | カマジクメクラセン    | OIL CAP                    |    |
| 37-2    | 062681012 | 6    | ナベコ437-40X10 | SCREW, PAN M4.37-40X10     |    |
| 47-2    | S28766001 | 1    | クロスプレートSB    | CLOTH PLATE (SB)           |    |
| 52-3    | S28021001 | 1    | スベリイタB       | SLIDE PLATE (B)            |    |
| 128     | S28052001 | 1    | ガイドL         | GUIDE (L)                  |    |
| 129     | S28053001 | 1    | ガイドR         | GUIDE (R)                  |    |
| 130     | 110072001 | 2    | シメネジ4.76     | SCREW, M4.76               |    |
|         |           |      | <0X1>        |                            |    |
| 47-2    | S28766001 | 1    | クロスプレートSB    | CLOTH PLATE (SB)           |    |
| 52-6    | S28024001 | 1    | スベリイタD       | SLIDE PLATE (D)            |    |
| 55-4    | S28030001 | 1    | マエカバーC       | FRONT COVER (C)            |    |
| 68-3    | S28060001 | 1    | ホジヨイタ        | SUPPORT PLATE              |    |
| 88-2    | S28042001 | 1    | ヨコカバーウワイタB   | SIDE COVER UPPER PLATE (B) |    |
| 200     | S28054001 | 1    | ヘムヌイガイドL     | HEM SEWING GUIDE (L)       |    |
| 201     | S28055001 | 1    | ガイドチップ       | GUIDE TIP                  |    |
| 202     | 100360003 | 1    | サラネジ2.38     | SCREW, FLAT M2.38          |    |
| 203     | S28056001 | 1    | ヘムヌイガイドR     | HEM SEWING GUIDE (R)       |    |
| 204     | 062680612 | 2    | ナベコ4.37-40X6 | SCREW, PAN M4.37-40X6      |    |
| 205     | 100645003 | 2    | ザガネ          | WASHER                     |    |
| 206     | S28059101 | 1    | ホジヨアンナイ      | SUB GUIDE                  |    |
| 207     | 062680512 | 1    | ナベコ437-40X5  | SCREW, PAN M4.37-40X5      |    |
| 208     | S28523001 | 1    | ヌノガイドRB      | CLOTH GUIDE (RB)           |    |
| 209     | 018680822 | 2    | アナボルト4.37X8  | BOLT, SOCKET M4.37X8       |    |
| 210     | 100645003 | 2    | ザガネ          | WASHER                     |    |
| 211     | S28831001 | 1    | ホジヨイタバネ      | SUPPORT PLATE SPRING       |    |
| 212     | 100105005 | 2    | シメネジ2.38     | SCREW, M2.38               |    |
|         |           |      | <033>        |                            |    |
| 128     | S28052001 | 1    | ガイドL         | GUIDE (L)                  |    |
| 129     | S28053001 | 1    | ガイドR         | GUIDE (R)                  |    |
| 130     | 110072001 | 2    | シメネジ4.76     | SCREW, M4.76               |    |

A3. 主体関係 / Machine body / Maschinengehäuse /  
 Corps de la machine / Cuerpo de la máquina

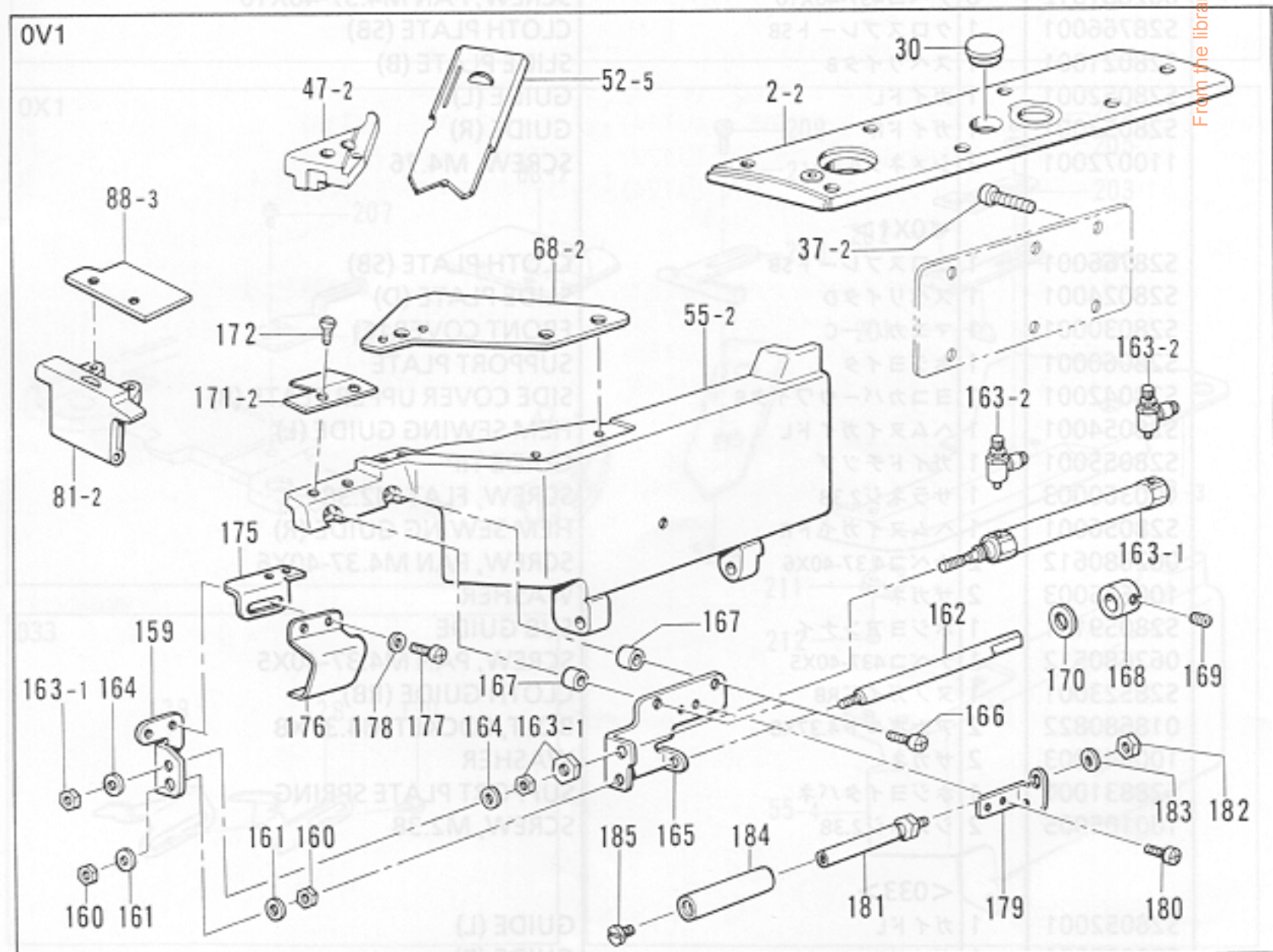
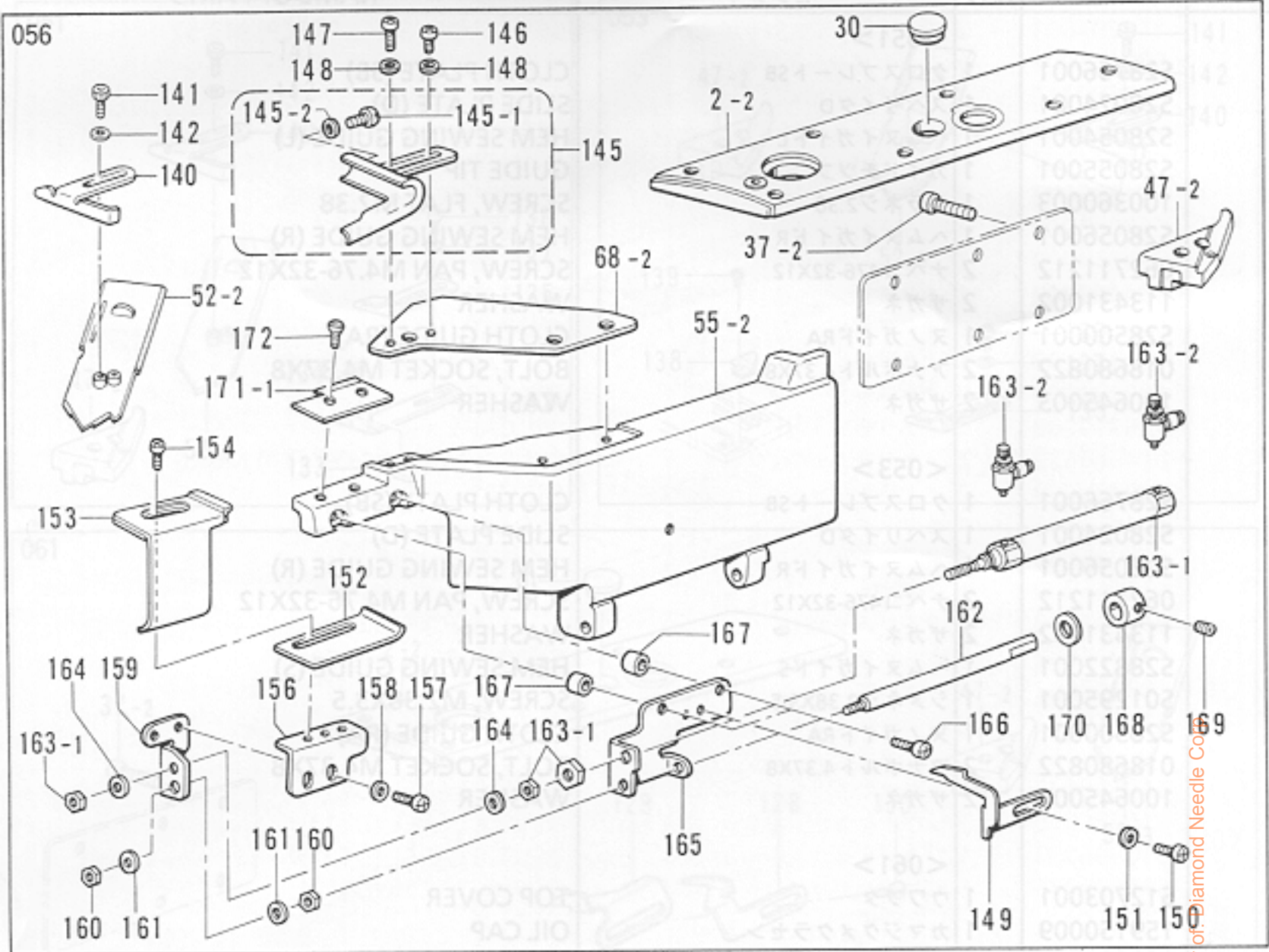

From the library of: Diamond Needle Co.

A3. 主体関係 / Machine body / Maschinengehäuse /  
Corps de la machine / Cuerpo de la máquina

| REF.NO. | CODE      | Q'TY | ヒンメイ          | NAME OF PARTS                | RM |
|---------|-----------|------|---------------|------------------------------|----|
|         |           |      | <056,0V1>     |                              |    |
| 2-2     | S12703001 | 1    | ウフフタ          | TOP COVER                    |    |
| 30      | 159150009 | 1    | カマジクメクラセン     | OIL CAP                      |    |
| 37-2    | 062681012 | 6    | ナベコ437-40X10  | SCREW, PAN M4.37-40X10       |    |
| 47-2    | S28766001 | 1    | クロスプレートSB     | CLOTH PLATE (SB)             |    |
| 55-2    | S28495001 | 1    | マエカバーD        | FRONT COVER (D)              |    |
| 68-2    | S28815001 | 1    | ホジヨイタC        | SUPPORT PLATE (C)            |    |
| 159     | S28506001 | 1    | ゴムガイドクドウイタ    | RUBBER GUIDE DRIVING PLATE   |    |
| 160     | 021500106 | 2    | 1シユナツト5       | NUT, 1 M5                    |    |
| 161     | 025050236 | 2    | ヒラザガネチユウ5     | WASHER, PLAIN M 5            |    |
| 162     | S28507000 | 1    | ガイドジク         | GUIDE SHAFT                  |    |
| 163     | S28508000 | 1    | エアーシリンダクミ     | AIR CYLINDER ASSY            |    |
| 163-1   | S28509000 | 1    | エアーシリンダ       | AIR CYLINDER                 |    |
| 163-2   | S23671000 | 2    | スピードコントローラ    | SPEED CONTROLLER             |    |
| 164     | 025040236 | 2    | ヒラザガネチユウ4     | WASHER, PLAIN M4             |    |
| 165     | S28510001 | 1    | シリンダドダイ       | SYLINDER BRACKET             |    |
| 166     | 062711612 | 2    | ナベコ476-32X16  | SCREW, PAN M4.76-32X16       |    |
| 167     | 153195001 | 2    | コロ            | ROLLER                       |    |
| 168     | 147402001 | 1    | セットカラー        | SET COLLAR                   |    |
| 169     | 014680422 | 1    | アナトメネジ4.37クボミ | SET SCREW, SOCKET (CP) M4.37 |    |
| 170     | 154599000 | 1    | ソレノイドクツシヨン    | SOLENOID CUSHION             |    |
| 172     | 107272002 | 2    | サラネジ4.37      | SCREW, FLAT M4.37            |    |
|         |           |      | <056>         |                              |    |
| 52-2    | S28493001 | 1    | スベリイタF        | SLIDE PLATE (F)              |    |
| 140     | S28500001 | 1    | ヌノガイドRA       | CLOTH GUIDE (RA)             |    |
| 141     | 018680822 | 2    | アナボルト4.37X8   | BOLT, SOCKET M4.37X8         |    |
| 142     | 100645003 | 2    | ザガネ           | WASHER                       |    |
| 145     | S28866001 | 1    | バインダーRクミ      | BINDER (R) ASSY              |    |
| 145-1   | 062670412 | 2    | ナベコ357-40X4   | SCREW, PAN M3.57-40X4        |    |
| 145-2   | 105161004 | 2    | ザガネ           | WASHER                       |    |
| 146     | 062710612 | 1    | ナベコ476-32X6   | SCREW, PAN M4.76-32X6        |    |
| 147     | 062711212 | 1    | ナベコ476-32X12  | SCREW, PAN M4.76-32X12       |    |
| 148     | 148847001 | 2    | ザガネ           | WASHER                       |    |
| 149     | S28502001 | 1    | ヌノガイドL        | CLOTH GUIDE (L)              |    |
| 150     | 062680812 | 2    | ナベコ437-40X8   | SCREW, PAN M4.37-40X8        |    |
| 151     | 100645003 | 2    | ザガネ           | WASHER                       |    |
| 152     | S28503000 | 1    | バインダーL        | BINDER (L)                   |    |
| 153     | S28504000 | 1    | ゴムガイド         | RUBBER GUIDE                 |    |
| 154     | 060680712 | 2    | バインド437-40X7  | SCREW, BIND M4.37-40X7       |    |
| 156     | S28505001 | 1    | ゴムガイドトリツケダイ   | RUBBER GUIDE SET BRACKET     |    |
| 157     | 062680812 | 2    | ナベコ437-40X8   | SCREW, PAN M4.37-40X8        |    |
| 158     | 100645003 | 2    | ザガネ           | WASHER                       |    |
| 171-1   | S28819001 | 1    | スベリイタS        | SLIDE PLATE (S)              |    |
|         |           |      | <0V1>         |                              |    |
| 52-5    | S28494001 | 1    | スベリイタG        | SLIDE PLATE (G)              |    |
| 81-2    | S28496001 | 1    | ヨコカバーB        | SIDE COVER (B)               |    |
| 88-3    | S28497001 | 1    | ヨコカバーウワイタC    | SIDE COVER UPPER PLATE (C)   |    |
| 171-2   | S28818001 | 1    | スベリイタS        | SLIDE PLATE (S)              |    |
| 175     | S28515001 | 1    | ジヨウギトリツケダイ    | RULLER SET BASE              |    |
| 176     | S28516001 | 1    | シリンダカバー       | CYLINDER COVER               |    |
| 177     | 062680812 | 2    | ナベコ437-40X8   | SCREW, PAN M4.37-40X8        |    |
| 178     | 025680133 | 2    | ヒラザガネシヨウ4.37  | WASHER, PLAIN S 4.37         |    |
| 179     | S28517001 | 1    | ホジヨローラササエ     | SUB ROLLER SUPPORT           |    |
| 180     | 062680812 | 2    | ナベコ437-40X8   | SCREW, PAN M4.37-40X8        |    |
| 181     | S28518001 | 1    | ホジヨローラジク      | SUB ROLLER SHAFT             |    |
| 182     | 105234003 | 1    | ナツト4.37       | NUT, M4.37                   |    |
| 183     | 100645003 | 1    | ザガネ           | WASHER                       |    |
| 184     | S28519000 | 1    | ホジヨローラ        | SUB ROLLER                   |    |
| 185     | 148834001 | 1    | シメネジ3.57      | SCREW, M3.57                 |    |

From the library of: Diamond Needle Corp



A4. 主体関係 / Machine body / Maschinengehäuse /  
Corps de la machine / Cuerpo de la máquina

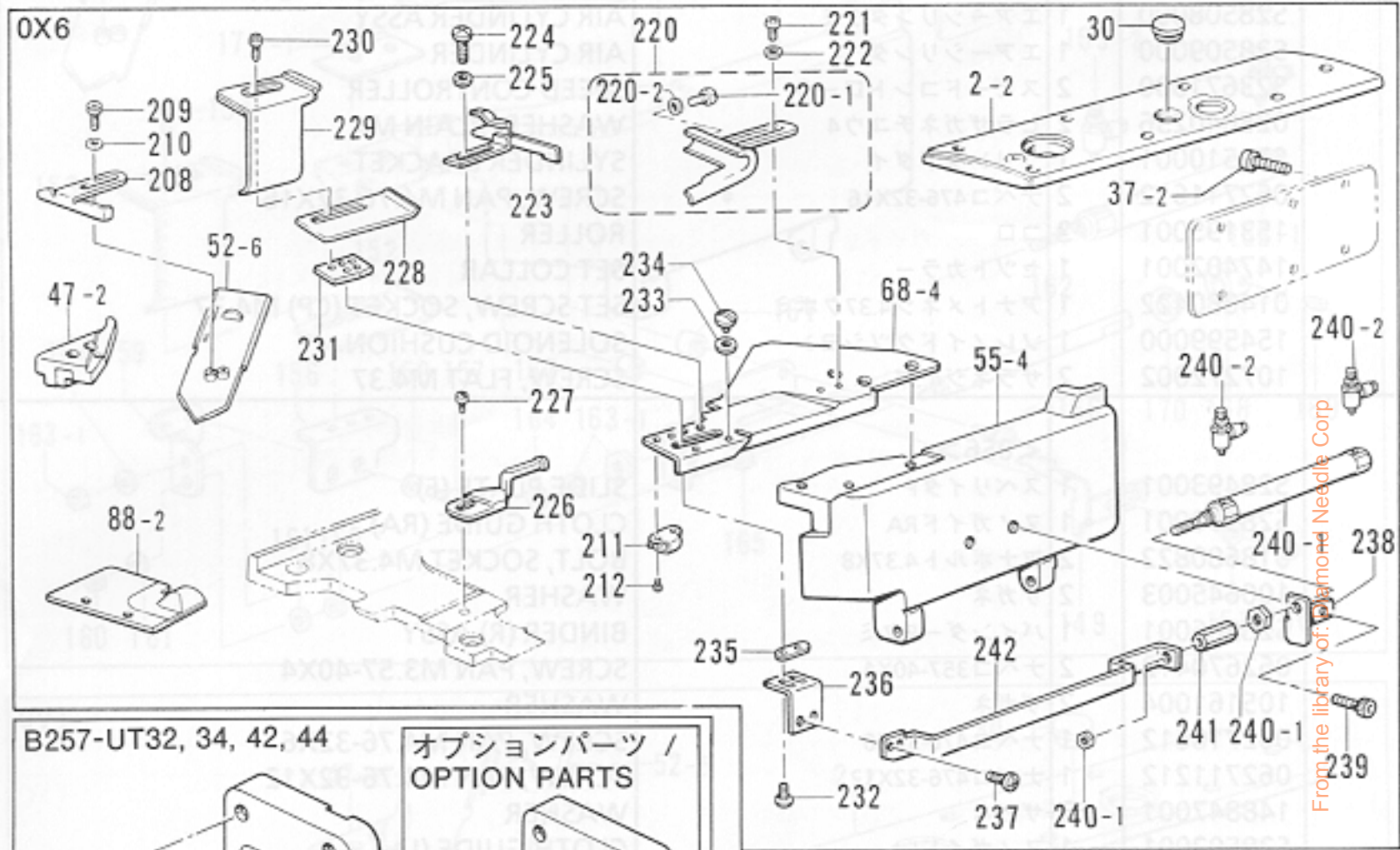
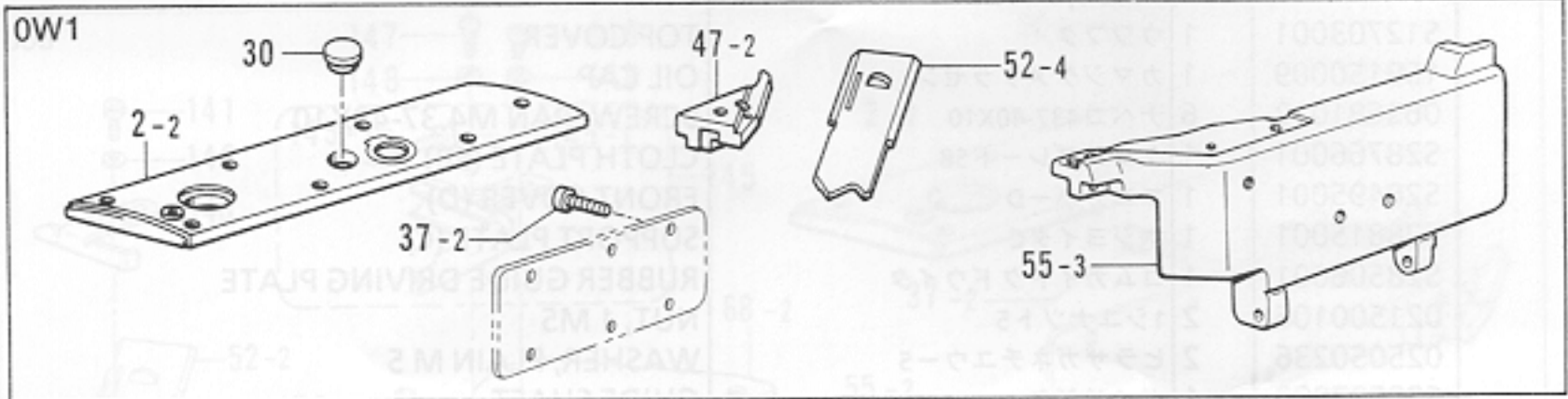

B257-UT32, 34, 42, 44

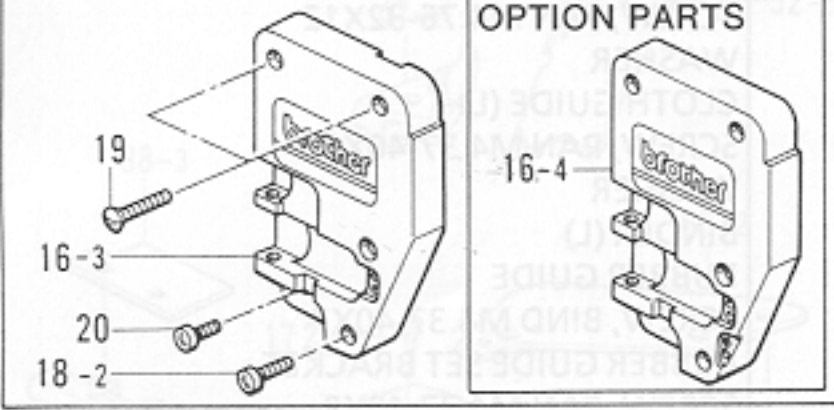

オプションパーツ /  
OPTION PARTS

オプションパーツ / OPTION PARTS

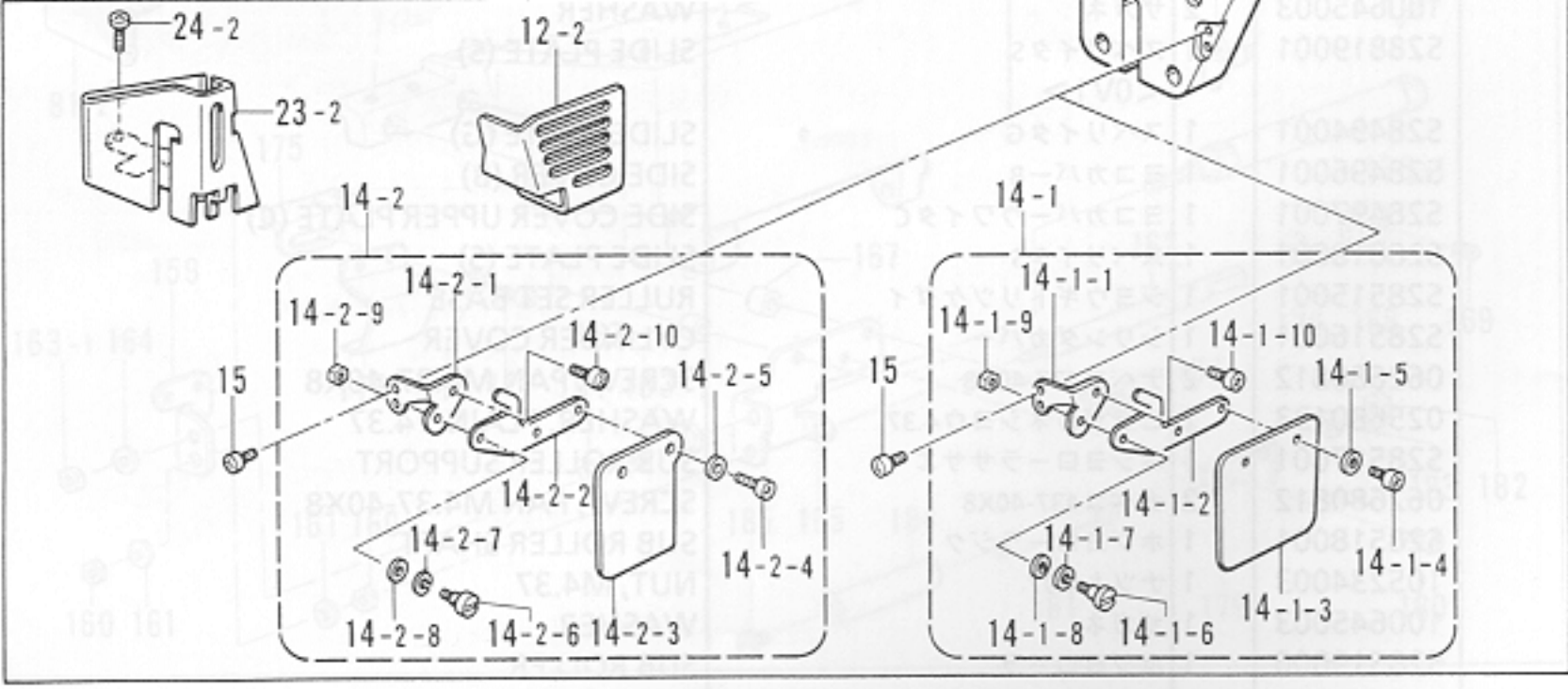
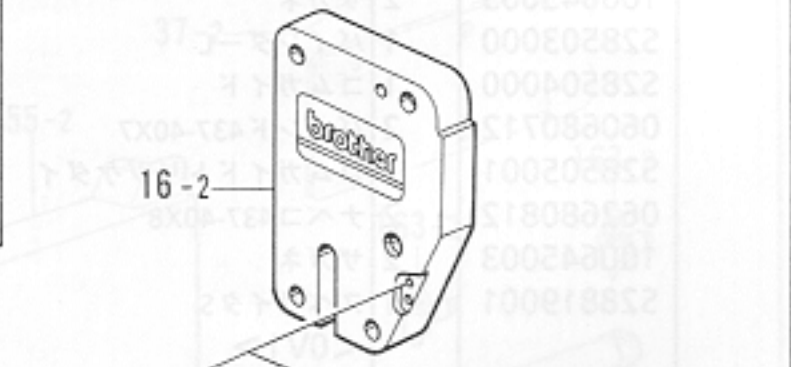

A4. 主体関係 / Machine body / Maschinengehäuse /  
Corps de la machine / Cuerpo de la máquina

| REF.NO. | CODE      | Q'TY | ヒンメイ         | NAME OF PARTS                       | RM |
|---------|-----------|------|--------------|-------------------------------------|----|
|         |           |      | <0W1>        |                                     |    |
| 2-2     | S12703001 | 1    | ウワフタ         | TOP COVER                           |    |
| 30      | 159150009 | 1    | カマジクメクラセン    | OIL CAP                             |    |
| 37-2    | 062681012 | 6    | ナベコ437-40X10 | SCREW, PAN M4.37-40X10              |    |
| 47-2    | S28766001 | 1    | クロスプレートSB    | CLOTH PLATE (SB)                    |    |
| 52-4    | S28022001 | 1    | スベリイタC       | SLIDE PLATE (C)                     |    |
| 55-3    | S28029001 | 1    | マエカバーB       | FRONT COVER (B)                     |    |
|         |           |      | <0X6>        |                                     |    |
| 2-2     | S12703001 | 1    | ウワフタ         | TOP COVER                           |    |
| 30      | 159150009 | 1    | カマジクメクラセン    | OIL CAP                             |    |
| 37-2    | 062681012 | 6    | ナベコ437-40X10 | SCREW, PAN M4.37-40X10              |    |
| 47-2    | S28766001 | 1    | クロスプレートSB    | CLOTH PLATE (SB)                    |    |
| 52-6    | S28024001 | 1    | スベリイタD       | SLIDE PLATE (D)                     |    |
| 55-4    | S28030001 | 1    | マエカバーC       | FRONT COVER (C)                     |    |
| 68-4    | S28521001 | 1    | ホジヨイタ        | SUPPORT PLATE                       |    |
| 88-2    | S28042001 | 1    | ヨコカバーウワイタB   | SIDE COVER UPPER PLATE (B)          |    |
| 208     | S28523001 | 1    | ヌノガイドRB      | CLOTH GUIDE (RB)                    |    |
| 209     | 018680822 | 2    | アナボルト4.37X8  | BOLT, SOCKET M4.37X8                |    |
| 210     | 100645003 | 2    | ザガネ          | WASHER                              |    |
| 211     | S28831001 | 1    | ホジヨイタバネ      | SUPPORT PLATE SPRING                |    |
| 212     | 100105005 | 2    | シメネジ2.38     | SCREW, M2.38                        |    |
| 220     | S28867001 | 1    | バインダーRクミ     | BINDER (R) ASSY                     |    |
| 220-1   | 062670412 | 2    | ナベコ357-40X4  | SCREW, PAN M3.57-40X4               |    |
| 220-2   | 105161004 | 2    | ザガネ          | WASHER                              |    |
| 221     | 062680512 | 2    | ナベコ437-40X5  | SCREW, PAN M4.37-40X5               |    |
| 222     | 100645003 | 2    | ザガネ          | WASHER                              |    |
| 223     | S28525000 | 1    | ヌノガイドL       | CLOTH GUIDE (L)                     |    |
| 224     | 062680512 | 2    | ナベコ437-40X5  | SCREW, PAN M4.37-40X5               |    |
| 225     | 100645003 | 2    | ザガネ          | WASHER                              |    |
| 226     | S28059101 | 1    | ホジヨアンナイ      | SUB GUIDE                           |    |
| 227     | 062680512 | 1    | ナベコ437-40X5  | SCREW, PAN M4.37-40X5               |    |
| 228     | S28503000 | 1    | バインダーL       | BINDER (L)                          |    |
| 229     | S28504000 | 1    | ゴムガイド        | RUBBER GUIDE                        |    |
| 230     | 060680712 | 2    | バインド437-40X7 | SCREW, BIND M4.37-40X7              |    |
| 231     | S28526001 | 1    | ゴムガイドトリツケダイ  | RUBBER GUIDE SET BRACKET            |    |
| 232     | 062680812 | 2    | ナベコ437-40X8  | SCREW, PAN M4.37-40X8               |    |
| 233     | 146354001 | 2    | ザガネ          | WASHER                              |    |
| 234     | 105130001 | 2    | シメネジ3.57     | SCREW, M3.57                        |    |
| 235     | S28527001 | 1    | トリツケダイスベリイタ  | BRACKET SLIDE PLATE                 |    |
| 236     | S28528001 | 1    | ゴムガイドクドウイタ   | RUBBER GUIDE DRIVING PLATE          |    |
| 237     | 062680612 | 2    | ナベコ4.37-40X6 | SCREW, PAN M4.37-40X6               |    |
| 238     | S28529001 | 1    | シリンダドダイ      | CYLINDER BRACKET                    |    |
| 239     | 018501022 | 2    | アナボルト5X10    | BOLT, SOCKET M5X10                  |    |
| 240     | S28508000 | 1    | エアーシリンダクミ    | AIR CYLINDER ASSY                   |    |
| 240-1   | S28509000 | 1    | エアーシリンダ      | AIR CYLINDER                        |    |
| 240-2   | S23671000 | 2    | スピードコントローラ   | SPEED CONTROLLER                    |    |
| 241     | S28532001 | 1    | ナット          | NUT                                 |    |
| 242     | S28533001 | 1    | ガイドカイヘイレンカン  | GUIDE OPENING AND CLOSING CONNECTOR |    |

A4. 主体関係 / Machine body / Maschinengehäuse /  
 Corps de la machine / Cuerpo de la máquina

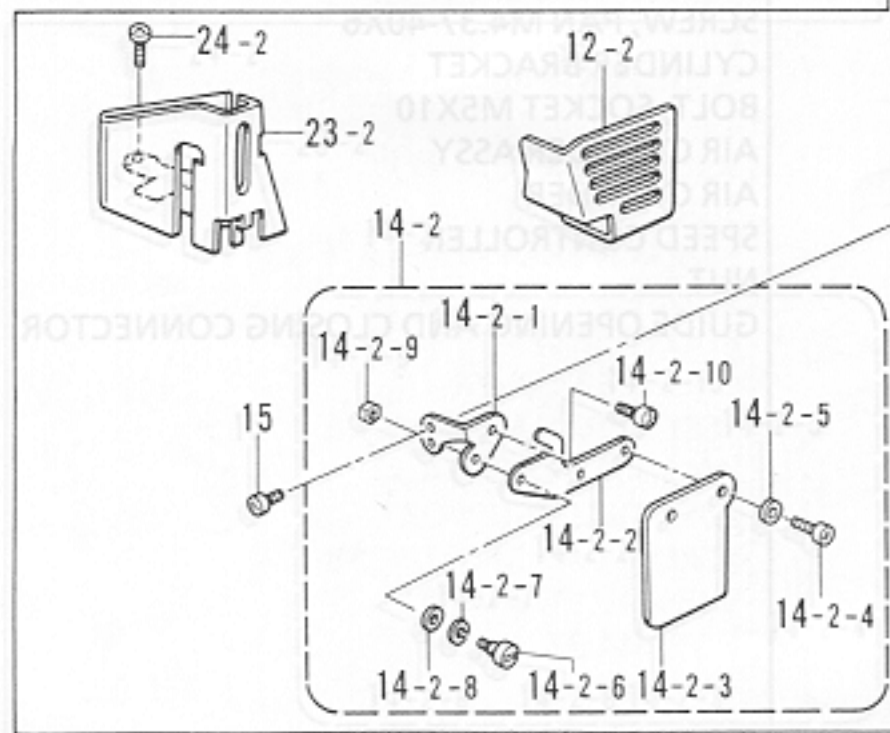
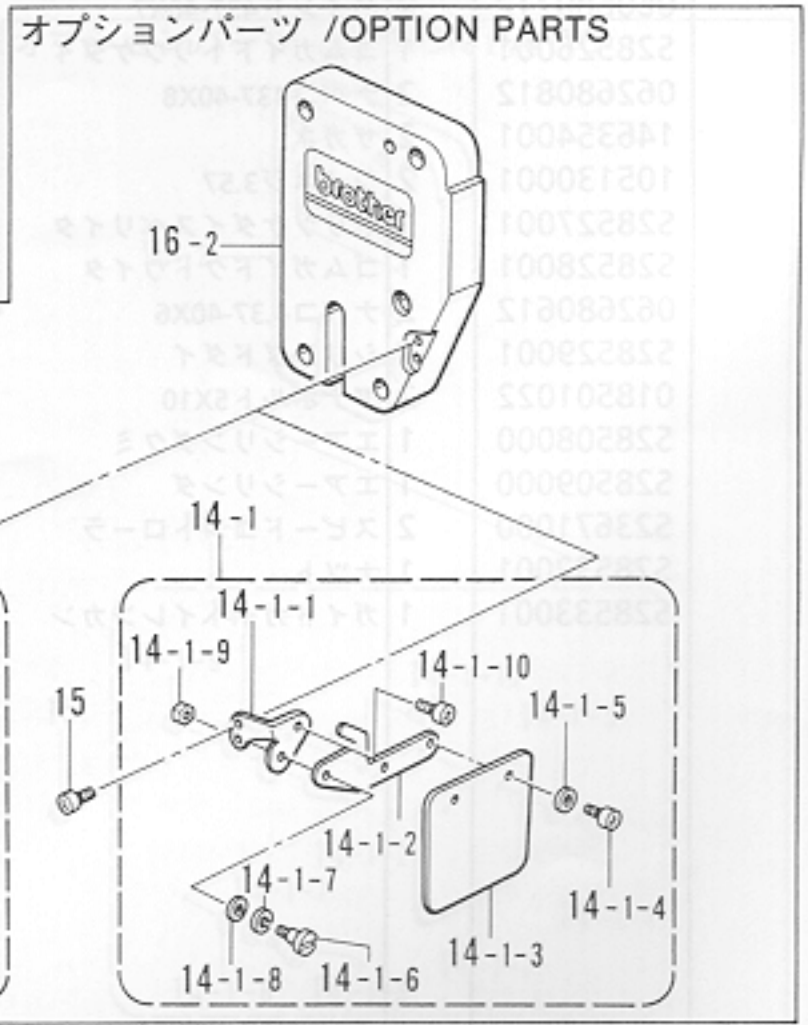
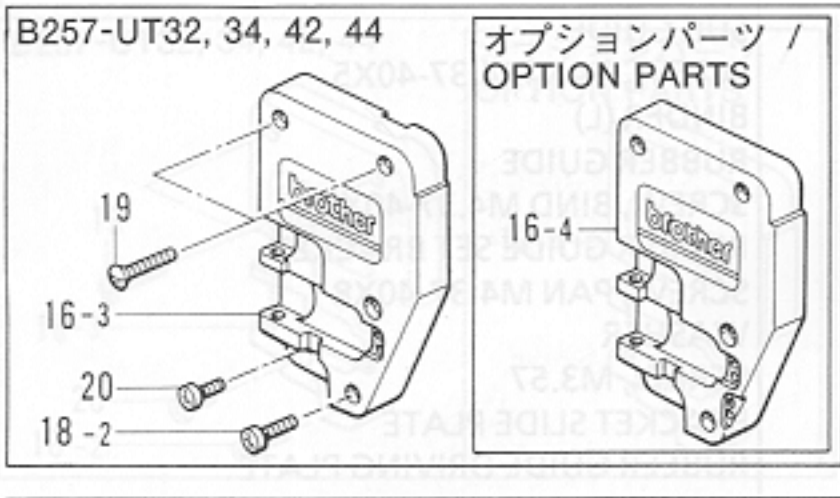
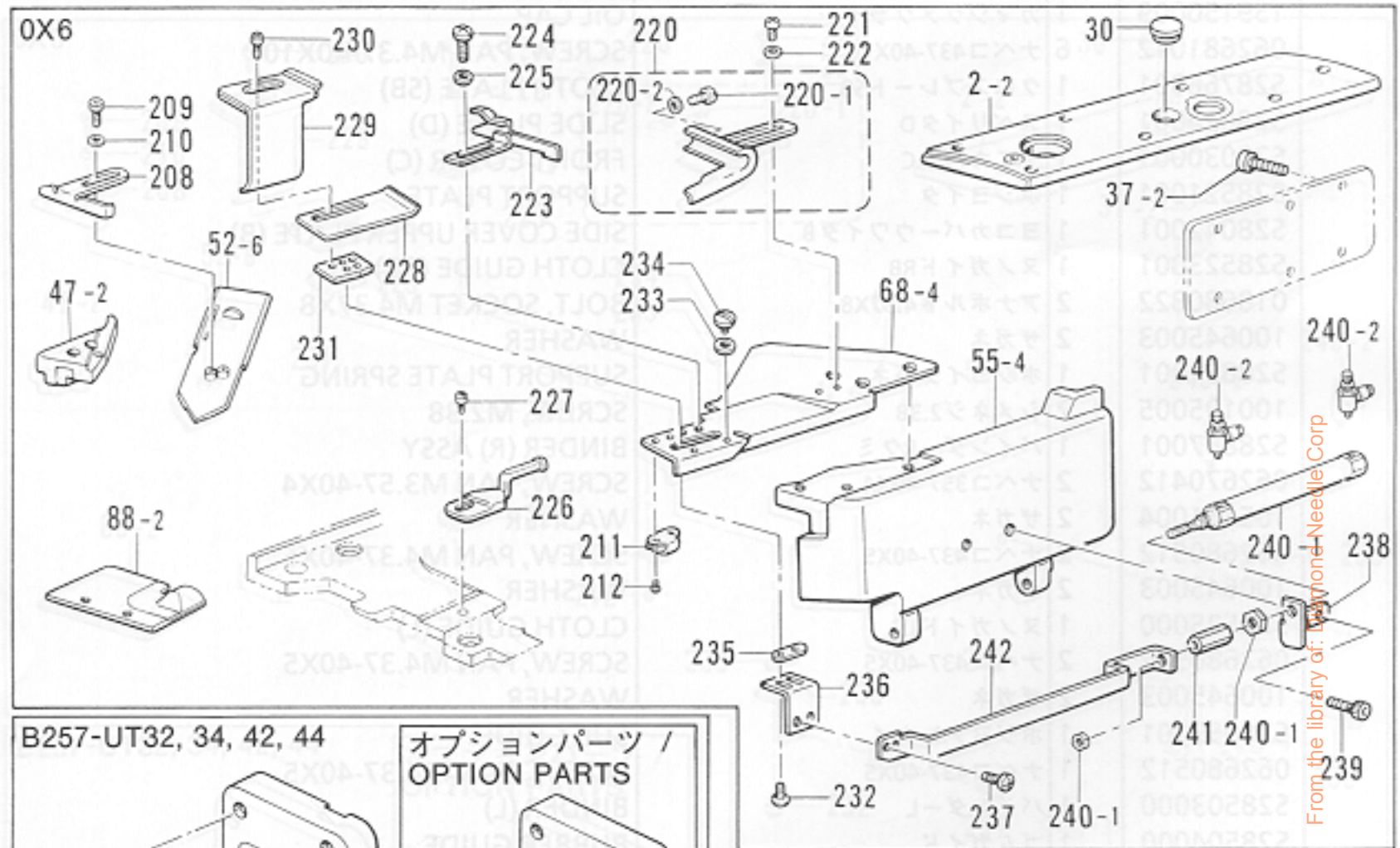
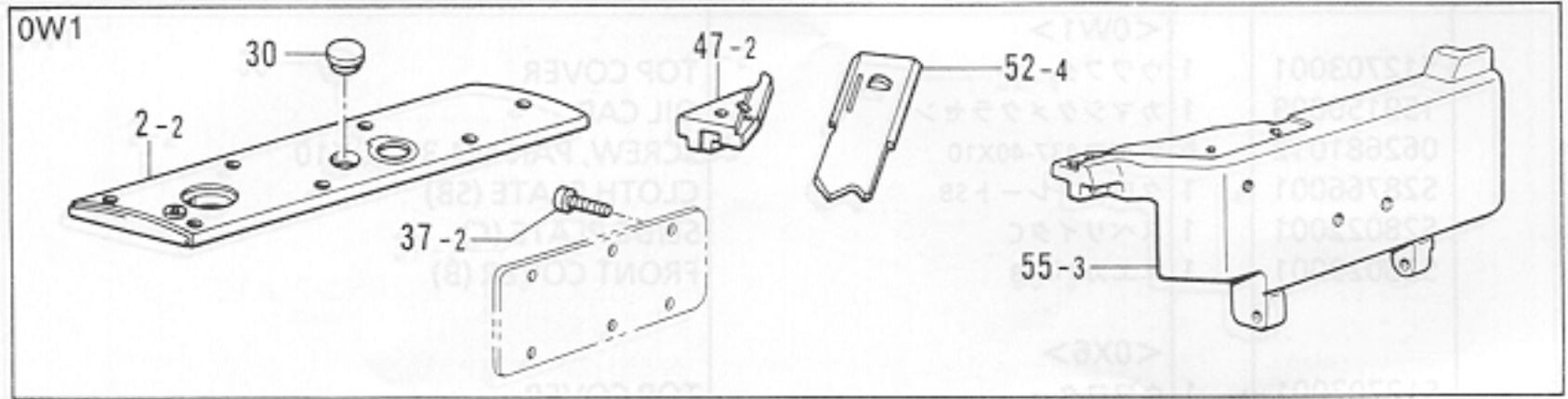

A4. 主体関係 / Machine body / Maschinengehäuse /  
Corps de la machine / Cuerpo de la máquina

| REF.NO.                   | CODE      | Q'TY | ヒンメイ          | NAME OF PARTS                         | RM |
|---------------------------|-----------|------|---------------|---------------------------------------|----|
| <B257-UT32,34,42,44>      |           |      |               |                                       |    |
| 16-3                      | S21960001 | 1    | メンイタ          | FACE PLATE                            |    |
| 18-2                      | 062681612 | 1    | ナベコ437-40X16  | SCREW, PAN M4.37-40X16                |    |
| 19                        | 156937001 | 2    | マルサラネジ4.37X25 | SCREW, FLAT M4.37X25                  |    |
| 20                        | 062681012 | 1    | ナベコ437-40X10  | SCREW, PAN M4.37-40X10                |    |
| <オプションパーツ / OPTION PARTS> |           |      |               |                                       |    |
| 16-4                      | S28811001 | 1    | メンイタ          | FACE PLATE                            |    |
| <オプションパーツ / OPTION PARTS> |           |      |               |                                       |    |
| 12-2                      | S28807001 | 1    | ハリイトクリカバー     | NEEDLE THREAD TAKE-UP COVER           |    |
| 14-1                      | S28802001 | 1    | アイガードクミ       | EYE GUARD ASSY                        |    |
| 14-1-1                    | S28803001 | 1    | アイガードドダイ      | EYE GUARD BASE                        |    |
| 14-1-2                    | S28804001 | 1    | アイガードトリツケイタ   | EYE GUARD SET PLATE                   |    |
| 14-1-3                    | S00075000 | 1    | アイガード         | EYE GUARD                             |    |
| 14-1-4                    | 062660512 | 2    | ナベコネジ318-40X5 | SCREW, PAN M3.18-40X5                 |    |
| 14-1-5                    | 025030232 | 2    | ヒラザガネチユウ3     | WASHER, PLAIN M 3                     |    |
| 14-1-6                    | S07317001 | 1    | ダンネジ3.57      | STUD SCREW, M3.57                     |    |
| 14-1-7                    | 028050246 | 1    | バネザガネ2-5      | WASHER, SPRING 2-5                    |    |
| 14-1-8                    | 025050232 | 1    | ヒラザガネチユウ5     | WASHER, PLAIN M 5                     |    |
| 14-1-9                    | 106129001 | 1    | ナツト3.57       | NUT, M3.57                            |    |
| 14-1-10                   | 060670512 | 1    | バインド357-40X5  | SCREW, BIND M3.57-40X5                |    |
| 14-2                      | S28805001 | 1    | アイガードクミ       | EYE GUARD ASSY                        |    |
| 14-2-1                    | S28803001 | 1    | アイガードドダイ      | EYE GUARD BASE                        |    |
| 14-2-2                    | S28804001 | 1    | アイガードトリツケイタ   | EYE GUARD SET PLATE                   |    |
| 14-2-3                    | S28806000 | 1    | アイガード         | EYE GUARD                             |    |
| 14-2-4                    | 062660512 | 2    | ナベコネジ318-40X5 | SCREW, PAN M3.18-40X5                 |    |
| 14-2-5                    | 025030232 | 2    | ヒラザガネチユウ3     | WASHER, PLAIN M 3                     |    |
| 14-2-6                    | S07317001 | 1    | ダンネジ3.57      | STUD SCREW, M3.57                     |    |
| 14-2-7                    | 028050246 | 1    | バネザガネ2-5      | WASHER, SPRING 2-5                    |    |
| 14-2-8                    | 025050232 | 1    | ヒラザガネチユウ5     | WASHER, PLAIN M 5                     |    |
| 14-2-9                    | 106129001 | 1    | ナツト3.57       | NUT, M3.57                            |    |
| 14-2-10                   | 060670512 | 1    | バインド357-40X5  | SCREW, BIND M3.57-40X5                |    |
| 15                        | 060680712 | 2    | バインド437-40X7  | SCREW, BIND M4.37-40X7                |    |
| 16-2                      | S28810001 | 1    | メンイタ          | FACE PLATE                            |    |
| 23-2                      | S28809001 | 1    | ハリボウテンピンカバー   | NEEDLE BAR TAKE-UP COVER              |    |
| 24-2                      | 060680712 | 2    | バインド437-40X7  | SCREW, BIND M4.37-40X7                |    |
| 5-1-1                     | S28054001 | 2    | ピン            | PIN                                   |    |
| 16-1                      | 018681022 | 4    | ボルト4.37X10    | BOLT, SOCKET M4.37X10                 |    |
| 18                        | S28075001 | 3    | イタササギ         | COLLAR                                |    |
| 39                        | 060680712 | 2    | バインド4.37-40X8 | SCREW, BIND M3.57-40X8                |    |
| 43                        | 060680712 | 2    | バインド4.37-40X8 | SCREW, BIND M3.57-40X8                |    |
| 44                        | S09127001 | 1    | メンイタ          | NEEDLE PLATE                          |    |
| 48                        | S28054001 | 1    | ピン            | SCREW, FLAT M3.57X6                   |    |
| 49                        | 014680422 | 1    | アイガードレバ       | NEEDLE GUARD (F) LEVER                |    |
| 50                        | S28054001 | 1    | ピン            | SET SCREW, SOCKET (CP) M4.37          |    |
| 51                        | S28054001 | 1    | ピン            | NEEDLE GUARD (F) HOLDER               |    |
| 52                        | S28054001 | 1    | ピン            | EYE GUARD HOLDER BUSH                 |    |
| 53                        | 014680422 | 1    | アイガードレバ       | SET SCREW, SOCKET (CP) M4.37          |    |
| 54                        | S28054001 | 1    | ピン            | NEEDLE GUARD (F)                      |    |
| 55                        | 014680422 | 1    | アイガードレバ       | SET SCREW, SOCKET (CP) M4.37          |    |
| 56                        | S28054001 | 1    | ピン            | NEEDLE GUARD (B) ECCENTRIC WHEEL ASSY |    |
| 56-1                      | 014680422 | 1    | アイガードレバ       | SET SCREW, SOCKET (CP) M4.37          |    |
| 58                        | S28054001 | 1    | ピン            | NEEDLE GUARD (B)                      |    |
| 59                        | 014680422 | 1    | アイガードレバ       | SET SCREW, SOCKET (CP) M4.37          |    |
| 60                        | S28054001 | 1    | ピン            | NEEDLE GUARD (B) HOLDER               |    |
| 61                        | S28054001 | 1    | ピン            | NEEDLE GUARD HOLDER BUSH              |    |
| 62                        | S28054001 | 1    | ピン            | SET COLLAR                            |    |
| 63                        | 014680422 | 1    | アイガードレバ       | SET SCREW, SOCKET (CP) M4.37          |    |
| 64                        | S28054001 | 1    | ピン            | NEEDLE GUARD (B)                      |    |

From the library of: Diamond Needle Corp

B. 上軸・針棒関係 / Upper shaft and needle bar mechanism / Obere Welle und Nadelstangenvorrichtung / Mécanisme de arbre supérieur et barra à aiguille / Mecanismo del eje superior y la barra de aguja

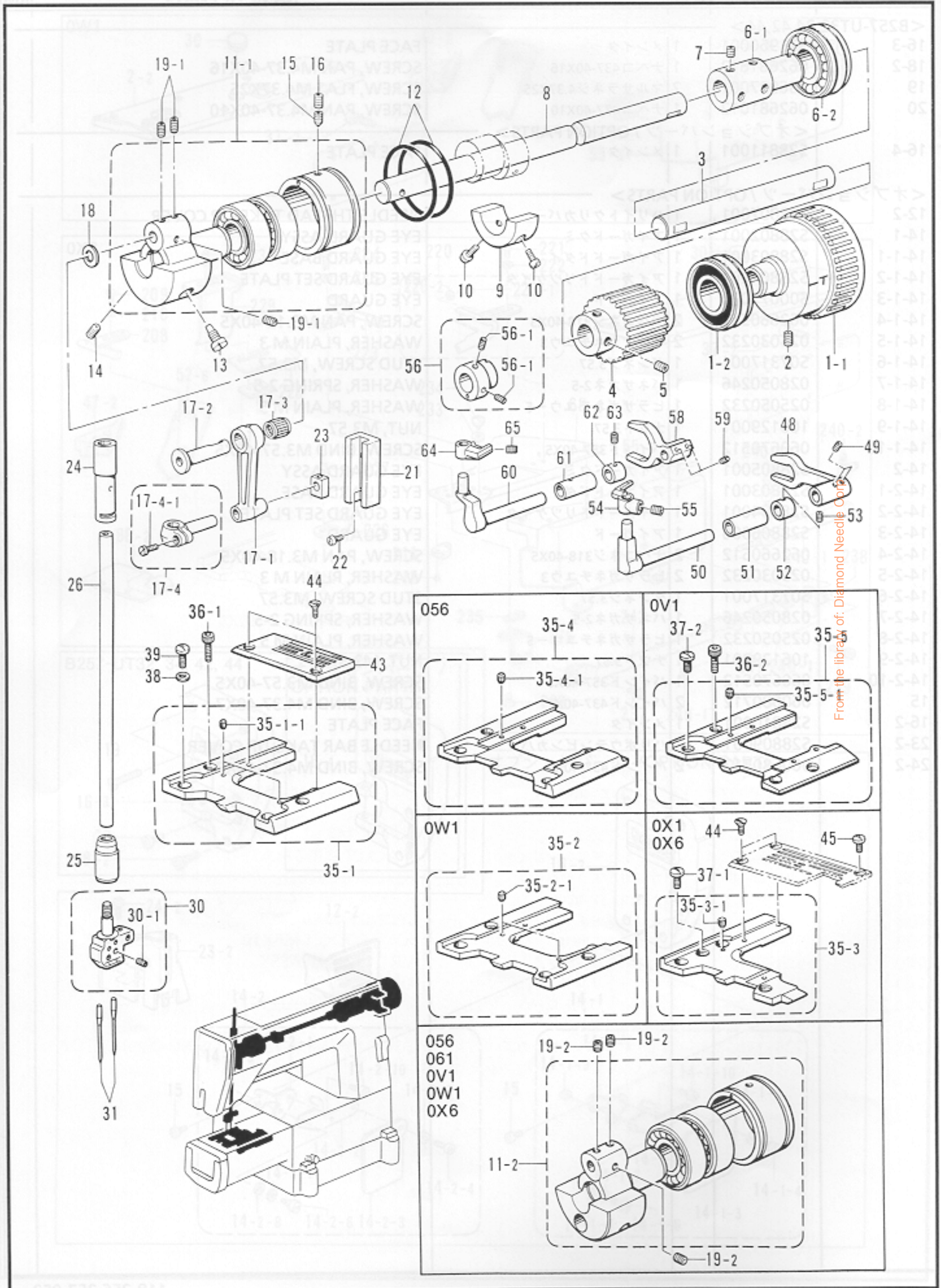

B. 上軸・針棒関係 / Upper shaft and needle bar mechanism / Obere Welle und Nadelstangenvorrichtung / Mécanisme de arbre supérieur et barra à aiguille / Mecanismo del eje superior y la barra de aguja

| REF.NO. | CODE      | Q'TY | ヒンメイ           | NAME OF PARTS                         | RM |
|---------|-----------|------|----------------|---------------------------------------|----|
| 1       | S28069009 | 1    | プーリクミ          | PULLEY ASSY                           |    |
| 1-1     | S28070009 | 1    | プーリ            | PULLEY                                |    |
| 1-2     | S14621001 | 1    | タマジクウケ6204LLB  | BALL BEARING, 6204LLB                 |    |
| 2       | 014770622 | 2    | アナトメネジ6.35クボミ  | SET SCREW, SOCKET (CP) M6.35          |    |
| 3       | S08682001 | 1    | ウワジクR          | UPPER SHAFT (R)                       |    |
| 4       | S08683000 | 1    | タイミングプーリU      | TIMING PULLEY (U)                     |    |
| 5       | 014770622 | 4    | アナトメネジ6.35クボミ  | SET SCREW, SOCKET (CP) M6.35          |    |
| 6       | S08684101 | 1    | ツギテLクミ         | JOINT (L) ASSY                        |    |
| 6-1     | S08685001 | 1    | ツギテL           | JOINT (L)                             |    |
| 6-2     | S08686101 | 1    | タマジクウケ6204LU   | BALL BEARING, 6204LU                  |    |
| 7       | 014770622 | 4    | アナトメネジ6.35クボミ  | SET SCREW, SOCKET (CP) M6.35          |    |
| 8       | S12724001 | 1    | ウワジクL          | UPPER SHAFT (L)                       |    |
| 9       | S08688001 | 1    | ウエイト           | WEIGHT                                |    |
| 10      | 062711012 | 2    | ナベコ476-32X10   | SCREW, PAN M4.76-32X10                |    |
| 11-1    | S28068001 | 1    | ハリボウ克蘭ククミ      | NEEDLE BAR CRANK ASSY                 |    |
| 12      | 081046870 | 2    | OリングS46        | O RING, S46                           |    |
| 13      | 104464001 | 1    | シメネジ7.14       | SCREW, M7.14                          |    |
| 14      | 014770622 | 1    | アナトメネジ6.35クボミ  | SET SCREW, SOCKET (CP) M6.35          |    |
| 15      | 118853001 | 1    | アナトメネジ5.95     | SET SCREW, SOCKET M5.95               |    |
| 16      | 014760622 | 1    | アナトメネジ5.95     | SET SCREW, SOCKET (CP) M5.95          |    |
| 17      | S08692101 | 1    | ハリボウレンカンクミ     | THREAD TAKE-UP LEVER ASSY             |    |
| 17-1    | S08693001 | 1    | ハリボウレンカン       | THREAD TAKE-UP LEVER                  |    |
| 17-2    | S08694001 | 1    | ハリボウレンカンジク     | THREAD TAKE-UP LEVER SHAFT            |    |
| 17-3    | S09120001 | 1    | ニードルジクウケ       | NEEDLE ROLLER BEARING                 |    |
| 17-4    | S30086001 | 1    | ハリボウダキクミ       | NEEDLE BAR CLAMP ASSY                 |    |
| 17-4-1  | 100064005 | 1    | シメネジ3.57       | SCREW, M3.57                          |    |
| 18      | 107153001 | 1    | ザガネ            | WASHER                                |    |
| 19-1    | 014760622 | 3    | アナトメネジ5.95     | SET SCREW, SOCKET (CP) M5.95          |    |
| 21      | 145688000 | 1    | ハリボウアンナイ       | NEEDLE BAR GUIDE                      |    |
| 22      | 062670612 | 2    | ナベコ357-40X6    | SCREW, PAN M3.57-40X6                 |    |
| 23      | 102630001 | 1    | ハリボウアンナイカクコマ   | NEEDLE BAR GUIDE SLIDE BLOCK          |    |
| 24      | S08696000 | 1    | ハリボウメタルU       | NEEDLE BAR BUSH (U)                   |    |
| 25      | S08697000 | 1    | ハリボウメタルD       | NEEDLE BAR BUSH (D)                   |    |
| 26      | S08698001 | 1    | ハリボウ           | NEEDLE BAR                            |    |
| 30      | ※         | 1    | ハリドメクミ         | NEEDLE CLAMP ASSY                     |    |
| 35-1    | S28063001 | 1    | ハリイタササエイタAクミ   | NEEDLE PLATE SUPPORT (A) ASSY         |    |
| 35-1-1  | S28064001 | 2    | ミソツキピン         | PIN                                   |    |
| 36-1    | 018681022 | 2    | アナボルト4.37X10   | BOLT, SOCKET M4.37X10                 |    |
| 38      | S28075001 | 2    | ハリイタササエイタカラー   | COLLAR                                |    |
| 39      | 060670812 | 2    | バインド357-40X8   | SCREW, BIND M3.57-40X8                |    |
| 43      | ※         | 1    | ハリイタ           | NEEDLE PLATE                          |    |
| 44      | S09121001 | 2    | マルサラネジ3.57X6   | SCREW, FLAT M3.57X6                   |    |
| 48      | S28087001 | 1    | ハリウケFレバー       | NEEDLE GUARD (F) LEVER                |    |
| 49      | 014680422 | 2    | アナトメネジ4.37クボミ  | SET SCREW, SOCKET (CP) M4.37          |    |
| 50      | S28088001 | 1    | ハリウケFホルダ       | NEEDLE GUARD (F) HOLDER               |    |
| 51      | S28096000 | 1    | ハリウケホルダメタル     | NEEDLE GUARD HOLDER BUSH              |    |
| 52      | S28090001 | 1    | セットカラー         | SET COLLAR                            |    |
| 53      | 014680422 | 1    | アナトメネジ4.37クボミ  | SET SCREW, SOCKET (CP) M4.37          |    |
| 54      | S28091001 | 1    | ハリウケF          | NEEDLE GUARD (F)                      |    |
| 55      | 014680422 | 1    | アナトメネジ4.37クボミ  | SET SCREW, SOCKET (CP) M4.37          |    |
| 56      | S28092001 | 1    | ハリウケBヘンシンリンククミ | NEEDLE GUARD (B) ECCENTRIC WHEEL ASSY |    |
| 56-1    | 014680422 | 2    | アナトメネジ4.37クボミ  | SET SCREW, SOCKET (CP) M4.37          |    |
| 58      | S28094001 | 1    | ハリウケBレバー       | NEEDLE GUARD (B) LEVER                |    |
| 59      | 014680422 | 2    | アナトメネジ4.37クボミ  | SET SCREW, SOCKET (CP) M4.37          |    |
| 60      | S28095001 | 1    | ハリウケBホルダ       | NEEDLE GUARD (B) HOLDER               |    |
| 61      | S28096000 | 1    | ハリウケホルダメタル     | NEEDLE GUARD HOLDER BUSH              |    |
| 62      | S28090001 | 1    | セットカラー         | SET COLLAR                            |    |
| 63      | 014680422 | 1    | アナトメネジ4.37クボミ  | SET SCREW, SOCKET (CP) M4.37          |    |
| 64      | S28097001 | 1    | ハリウケB          | NEEDLE GUARD (B)                      |    |
| 65      | 014680422 | 1    | アナトメネジ4.37クボミ  | SET SCREW, SOCKET (CP) M4.37          |    |

From the library of: Diamond Needle Corp

B. 上軸・針棒関係 / Upper shaft and needle bar mechanism / Obere Welle und Nadelstangenvorrichtung / Mécanisme de arbre supérieur et barra à aiguille / Mecanismo del eje superior y la barra de aguja

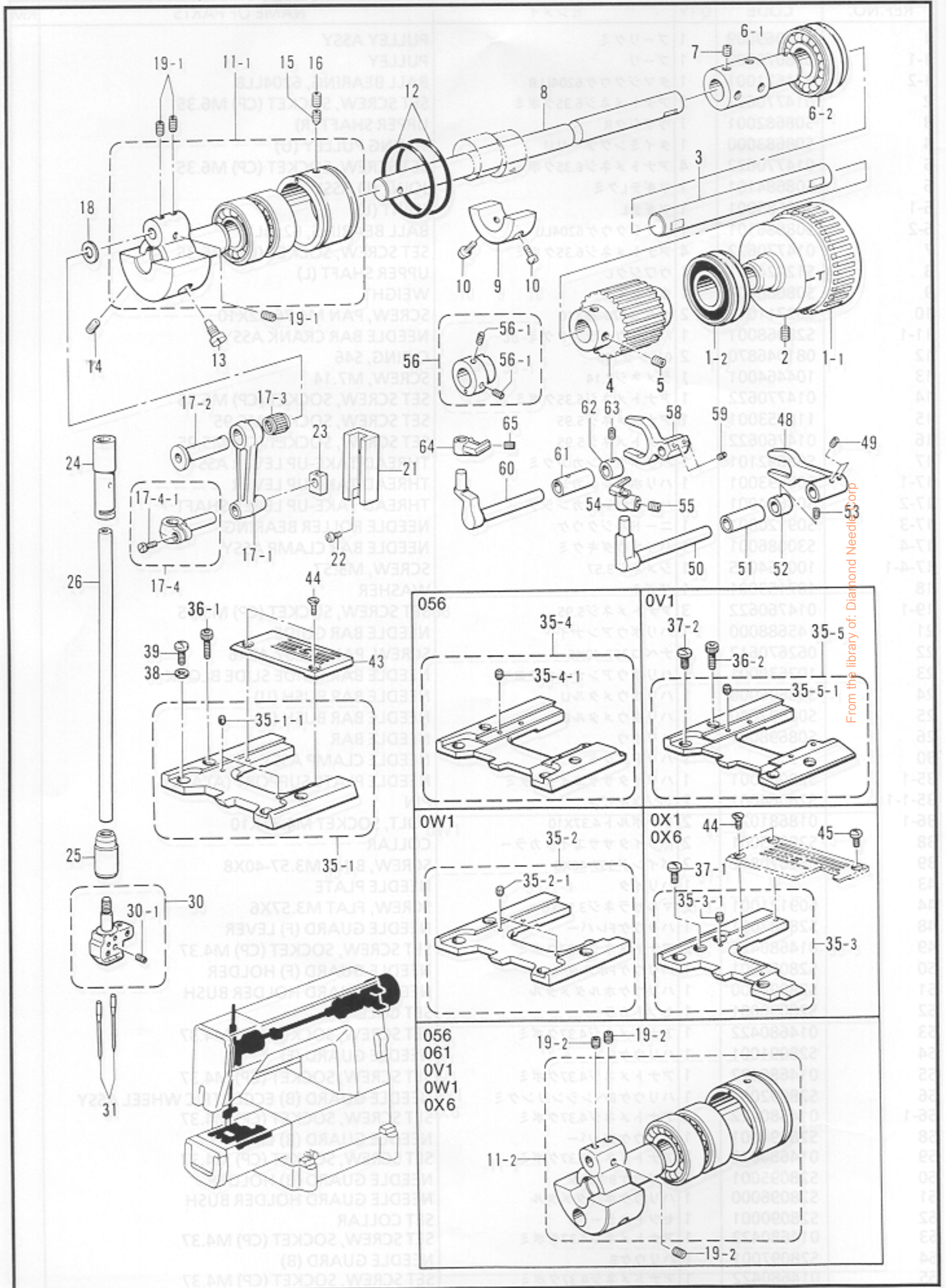

B. 上軸・針棒関係 / Upper shaft and needle bar mechanism / Obere Welle und Nadelstangenvorrichtung / Mécanisme de arbre supérieur et barra à aiguille / Mecanismo del eje superior y la barra de aguaja

| REF.NO.                            | CODE  | Q'TY                  | ヒンメイ  | NAME OF PARTS   | RM |
|------------------------------------|---|-----------------------|---|---|----|
| 30-1<br>31                         | 146427001<br>S08715010  | 2<br>2                | <-1,-2,-3,-4,-5><br>アナトメネジ3.18クボミ<br>ミシンハリUYX128GAS                         | SET SCREW, SOCKET (CP) M3.18<br>NEEDLE UYX128GAS  |    |
| 30-1<br>31                         | 146427001<br>S08715010  | 3<br>3                | <-6,-7,-8><br>アナトメネジ3.18クボミ<br>ミシンハリUYX128GAS                               | SET SCREW, SOCKET (CP) M3.18<br>NEEDLE UYX128GAS  |    |
| 11-2<br>19-2                       | S12725101<br>152718001  | 1<br>3                | <056,061,0V1,0W1,0X6><br>ハリボウ克蘭ククミ<br>アナトメネジ5.95                            | NEEDLE BAR CRANK ASSY<br>SET SCREW, SOCKET M5.95  |    |
| 35-2<br>35-2-1                     | S28065001<br>S28064001  | 1<br>2                | <0W1><br>ハリイタササエイタBクミ<br>ミゾツキピン   | NEEDLE PLATE SUPPORT (B) ASSY<br>PIN  |    |
| 35-3<br>35-3-1<br>37-1<br>44<br>45 | S28066001<br>S28064001<br>153208002<br>S09121001<br>100257010 | 1<br>1<br>2<br>2<br>1 | <0X1,0X6><br>ハリイタササエイタDクミ<br>ミゾツキピン<br>シメネジ4.37<br>マルサラネジ3.57X6<br>シメネジ3.57 | NEEDLE PLATE SUPPORT (D) ASSY<br>PIN<br>SCREW, M4.37<br>SCREW, FLAT M3.57X6<br>SCREW, M3.57 |    |
| 35-4<br>35-4-1                     | S28512001<br>S28064001  | 1<br>2                | <056><br>ハリイタササエイタEクミ<br>ミゾツキピン   | NEEDLE PLATE SUPPORT (E) ASSY<br>PIN  |    |
| 35-5<br>35-5-1<br>36-2<br>37-2     | S28513001<br>S28064001<br>018681022<br>153208002              | 1<br>2<br>1<br>1      | <B257-0V1><br>ハリイタササエイタFクミ<br>ミゾツキピン<br>アナボルト4.37X10<br>シメネジ4.37            | NEEDLE PLATE SUPPORT (F) ASSY<br>PIN<br>BOLT, SOCKET M4.37X10<br>SCREW, M4.37               |    |
| 32-2                               | S28800001   | 1                     | <B256-UT12,14,22,24><br>フィンガーガードC   | FINGER GUARD (C)  |    |
| 32-3                               | S28801001   | 1                     | <B257-UT32,34,42,44><br>フィンガーガードB   | FINGER GUARD (B)  |    |

From the library of: Diamond Needle Corp



C1. 押工関係 / Presser foot mechanism / Stoffdrückerfuß /  
 Mécanisme de pied presseur / Mecanismo de la prensa tela

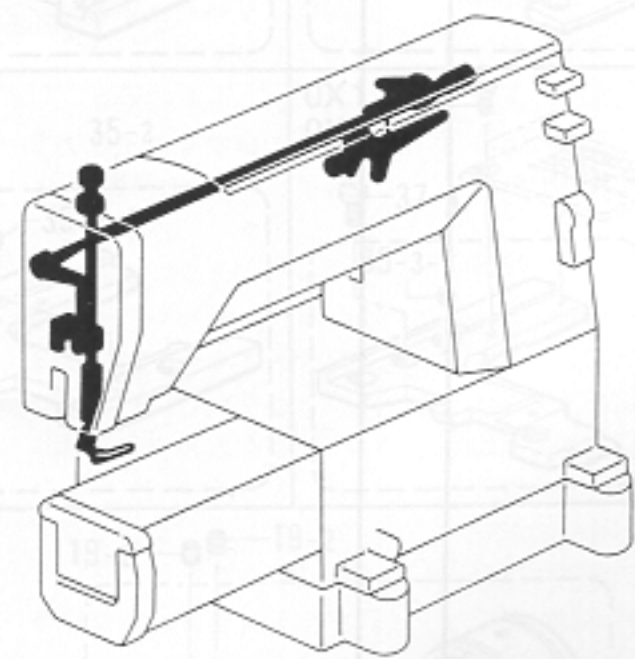
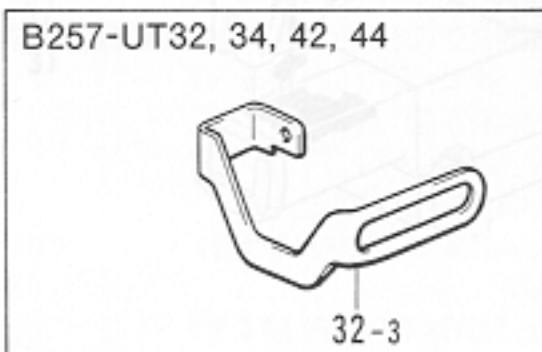
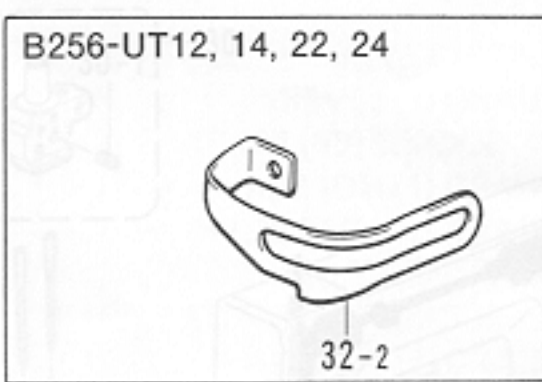
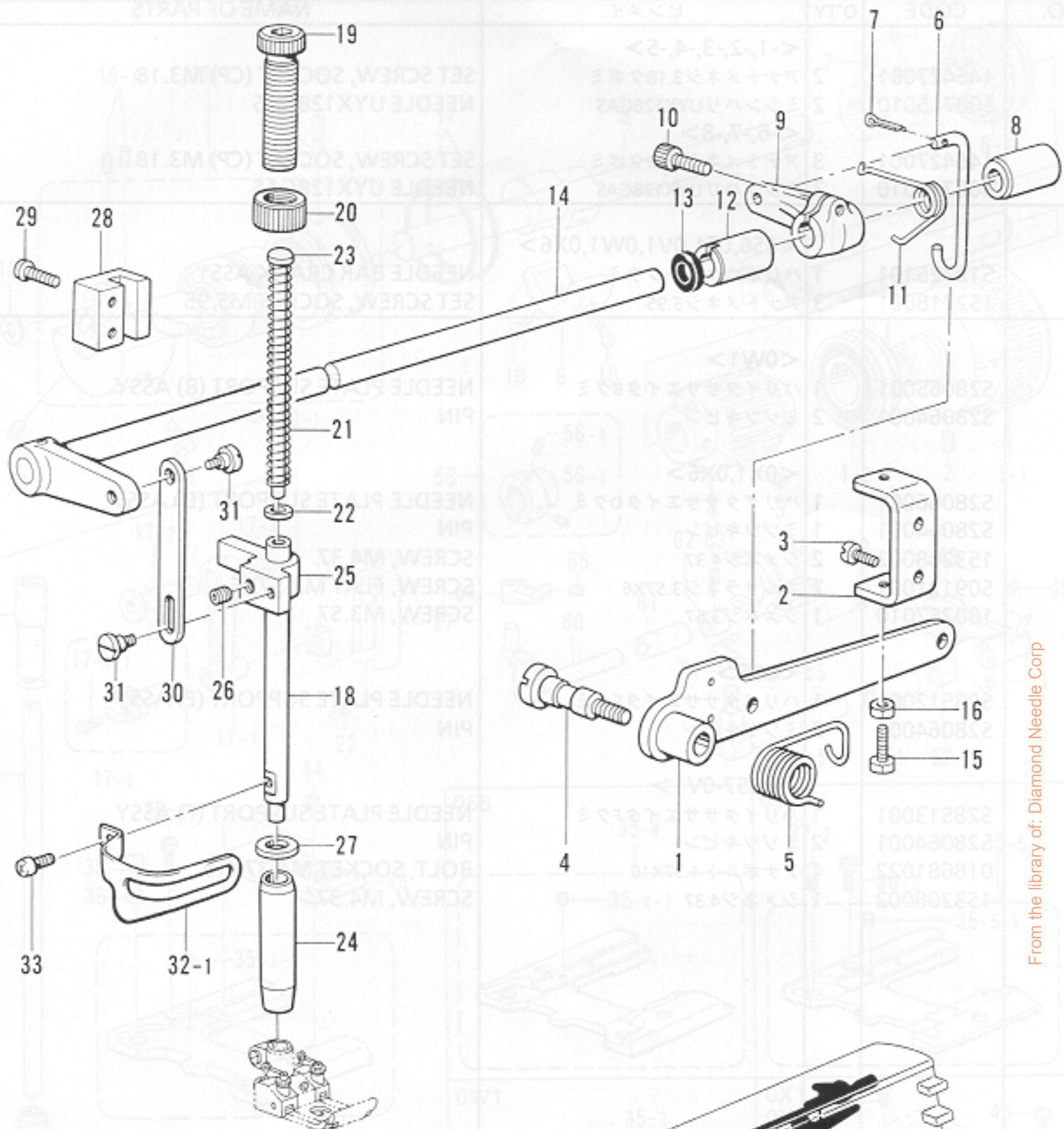

From the library of: Diamond Needle Corp

C1. 押工関係 / Presser foot mechanism / Stoffdrückerfuß /  
 Mécanisme de pied presseur / Mecanismo de la prensa tela

| REF.NO.      | CODE      | Q'TY | ヒンメイ                 | NAME OF PARTS                     | RM |
|--------------|-----------|------|----------------------|-----------------------------------|----|
| 1 0-1        | S21829001 | 1    | オサエアゲレバーR            | PRESSER BAR LIFTER LEVER (R)      |    |
| 2 0-1-1      | 146522101 | 1    | レバーチヨウセツイタ           | LEVER ADJUST PLATE                |    |
| 3 0-1-2      | 060680712 | 2    | バインド437-40X7         | SCREW, BIND M4.37-40X7            |    |
| 4 0-1-3      | S21830001 | 1    | ダンネジ7.94             | STUD SCREW, M7.94                 |    |
| 5 0-1-4      | 143325001 | 1    | オサエアシアゲレバーバネ         | SPRING                            |    |
| 6 0-1-5      | S08769001 | 1    | オサエアゲリンク             | PRESSER BAR LIFTER LINK           |    |
| 7 0-1-6      | 110793001 | 1    | ワリピン                 | PIN, COTTER                       |    |
| 8 0-1-7      | 155220000 | 1    | ホジヨアツメタルR            | AUTO PRESSER ARM BUSH (R)         |    |
| 9 0-1-8      | 154956001 | 1    | オサエアシアゲMレバー          | PRESSER FOOT LIFTER INSIDE LEVER  |    |
| 10           | 018771432 | 1    | アナボルト635-40X14       | BOLT, SOCKET M6.35-40X14          |    |
| 11 033>      | 154957001 | 1    | オサエアゲMレバーバネ          | SPRING                            |    |
| 12 2         | S08770000 | 1    | ジクメタル                | SHAFT BUSH                        |    |
| 13 2-1       | 155539000 | 1    | ダストシール               | DUST SEAL                         |    |
| 14 2-2       | S08771001 | 1    | オサエアゲレバーLクミ          | PRESSER BAR LIFTER LEVER (L) ASSY |    |
| 15 2-3       | 017711612 | 1    | ボルト4.76X16           | BOLT, M4.76X16                    |    |
| 16 2-4       | 110161006 | 1    | ナット4.76              | NUT, M4.76                        |    |
| 18 2-5       | S08774001 | 1    | オサエボウ                | PRESSER BAR                       |    |
| 19 2-6       | S31012001 | 1    | オサエチヨウセツネジ           | ADJUST SCREW                      |    |
| 20 2-7       | S31013001 | 1    | チヨウセツネジツマミナット        | NUT                               |    |
| 21 2-8       | 141728001 | 1    | オサエバネ                | SPRING                            |    |
| 22           | 140407001 | 1    | ザガネ                  | WASHER                            |    |
| 23 051,053,0 | 141208001 | 1    | オサエバネアンナイ            | SPRING GUIDE                      |    |
| 24 3         | 145472001 | 1    | オサエボウメタル             | PRESSER BAR BUSH                  |    |
| 25 3-1       | S00879001 | 1    | オサエボウダキ              | PRESSER BAR CLAMP                 |    |
| 26 3-2       | 014760622 | 1    | アナトメネジ5.95           | SET SCREW, SOCKET (CP) M5.95      |    |
| 27 3-3       | 154596000 | 1    | イトキリカムレバークツシヨン       | CUSHION                           |    |
| 28 3-4       | S08775000 | 1    | オサエボウアンナイ            | PRESSER BAR GUIDE                 |    |
| 29 3-5       | 062681412 | 2    | ナベコ437-40X14         | SCREW, PAN M4.37-40X14            |    |
| 30 3-6       | S08776001 | 1    | オサエアゲイタ              | PRESSER BAR LIFTER PLATE          |    |
| 31 3-7       | S08777001 | 2    | ダンネジ4.37             | STUD SCREW, M4.37                 |    |
| 32-1 8       | S28798001 | 1    | フィンガーガードA            | FINGER GUARD (A)                  |    |
| 33           | 062670812 | 1    | ナベコ3.57-40X8         | SCREW, PAN M3.57-40X8             |    |
| 36-3         | S28107101 |      |                      | CLOTH PRESSER                     |    |
| 37 051,053,0 | 062630412 |      | <B256-UT12,14,22,24> | SCREW, PAN M2.38-56X4             |    |
| 32-2         | S28800001 | 1    | フィンガーガードC            | FINGER GUARD (C)                  |    |
| 36-4         | S28108101 |      |                      | CLOTH PRESSER                     |    |
| 37 051,053,0 | 062630412 |      | <B257-UT32,34,42,44> | SCREW, PAN M2.38-56X4             |    |
| 32-3         | S28801001 | 1    | フィンガーガードB            | FINGER GUARD (B)                  |    |
| <B257-UV1    |           |      |                      |                                   |    |
| 40-4         |           |      |                      | PRESSER FOOT ASSY                 |    |
| 40-4-1       | S28558001 |      |                      | EDGE PRESSER ASSY                 |    |
| 40-4-2       | S08806101 |      |                      | PRESSER FOOT BASE                 |    |
| 40-4-3       | S00054005 |      |                      | SCREW, M3.57                      |    |
| 40-4-4       | S08807101 |      |                      | PIN                               |    |
| 40-4-5       | 041812346 |      |                      | RETAINING RING, E 1.6             |    |
| 40-4-6       | 145472001 |      |                      | SET SCREW, SOCKET (CP) M3.18      |    |
| 40-4-7       | S08808101 |      |                      | STOPPER SCREW                     |    |
| 40-4-8       | 021660102 |      |                      | NUT, 1 M3.18                      |    |
| 40-4-9       | S08809001 |      |                      | SCREW, M2.38X3.5                  |    |
| 40-4-10      | S08810001 |      |                      | SCREW, BIND M2.38-56X4            |    |
| 40-4-11      | 060630412 |      |                      | GUIDE                             |    |
| 40-4-12      | S28560001 |      |                      | SCREW, M3.18                      |    |
| 40-4-13      | 147544052 |      |                      | SPRING                            |    |
| 40-4-14      | S08812001 |      |                      |                                   |    |

From the library of: Diamond Needle Corp

C2. 押工関係 / Presser foot mechanism / Stoffdrückerfuß /  
 Mécanisme de pied presseur / Mecanismo de la prensa tela

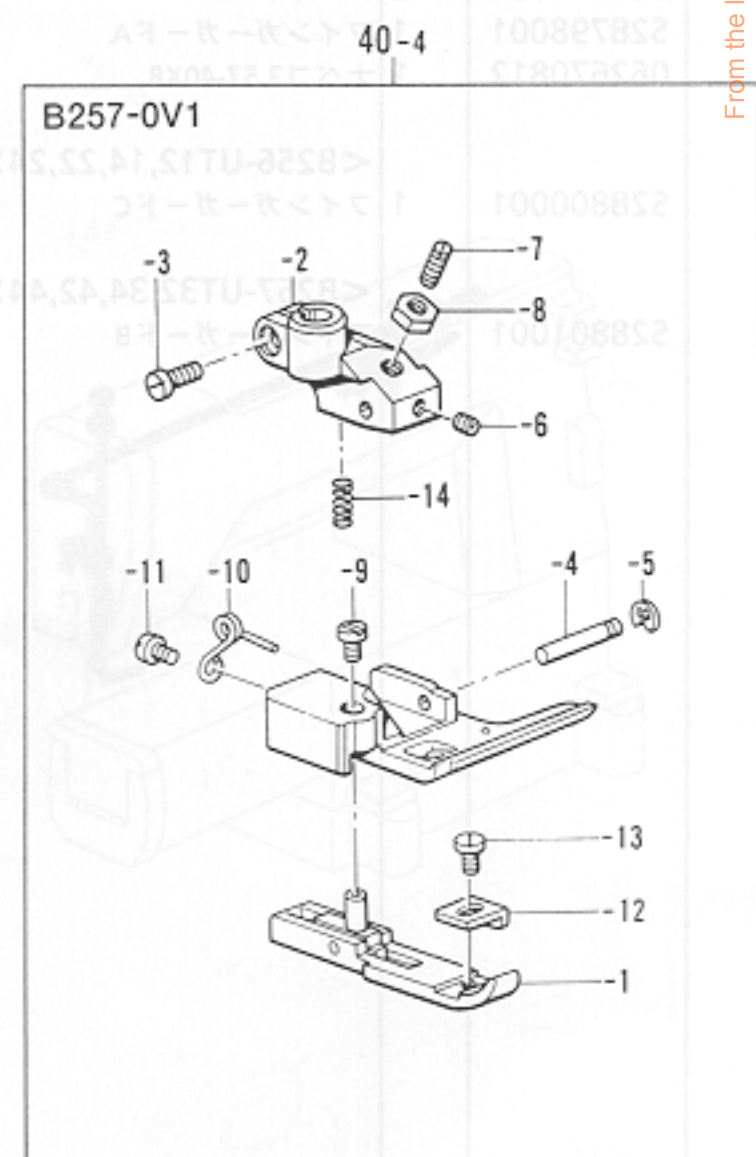
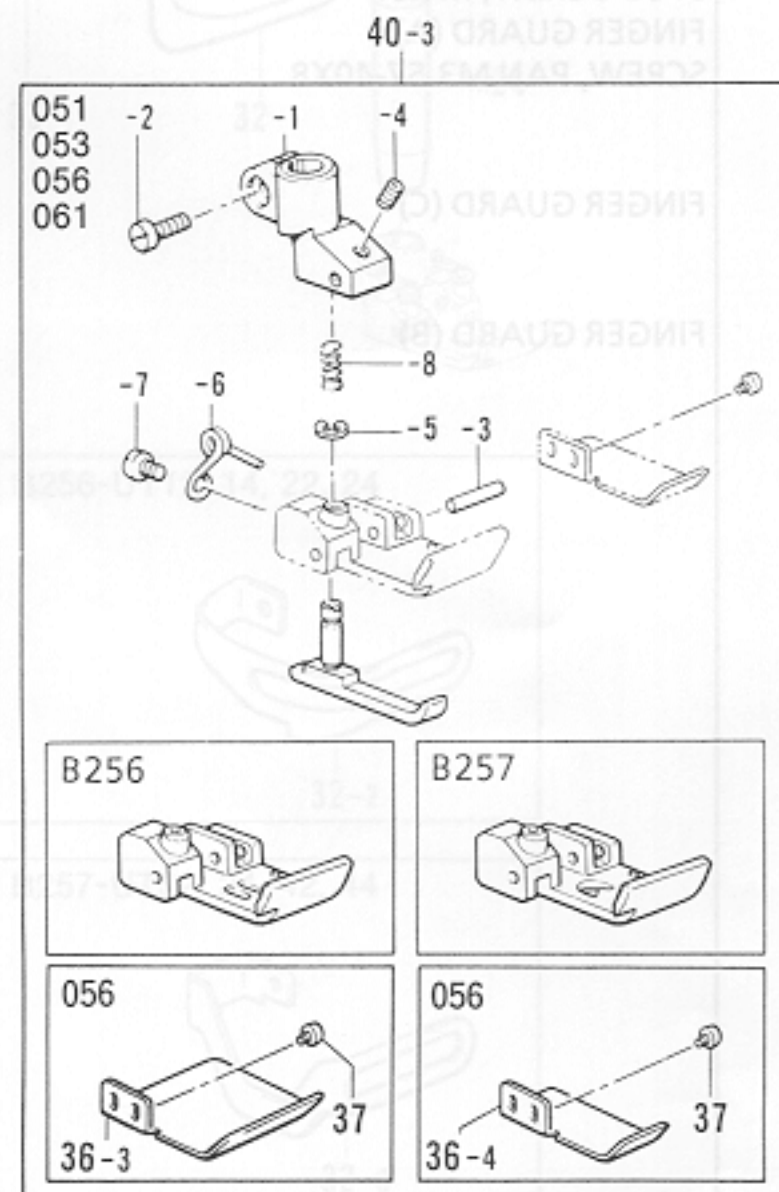
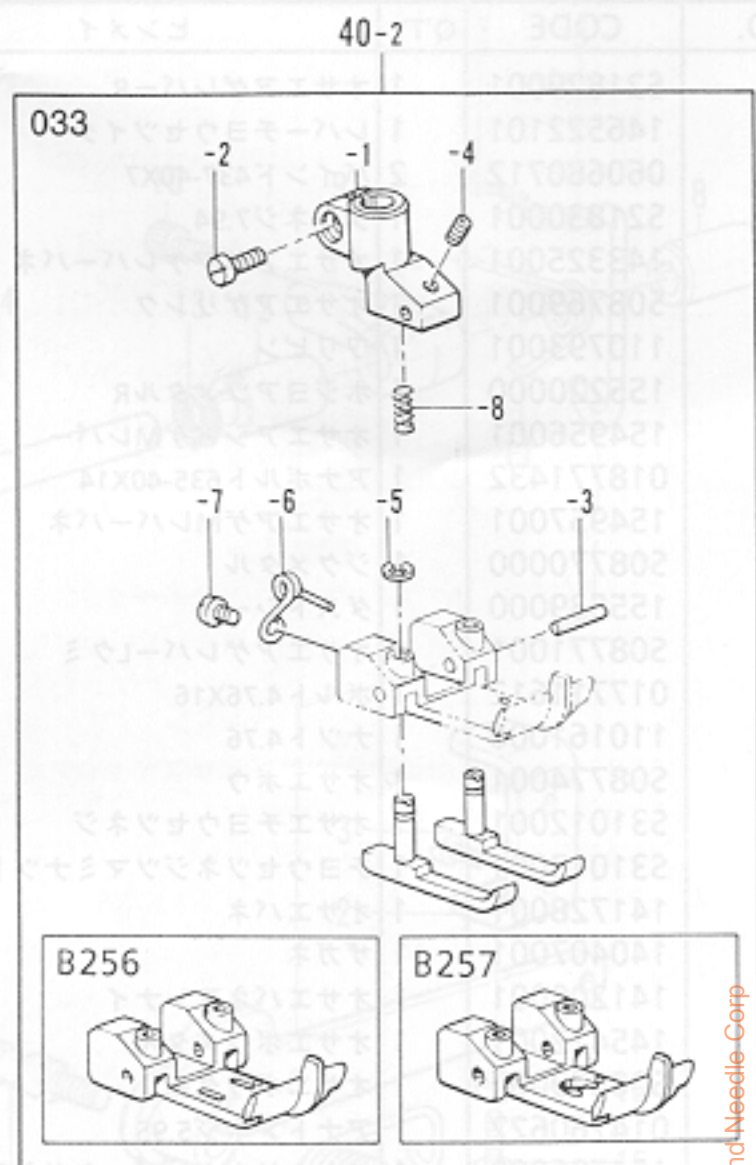
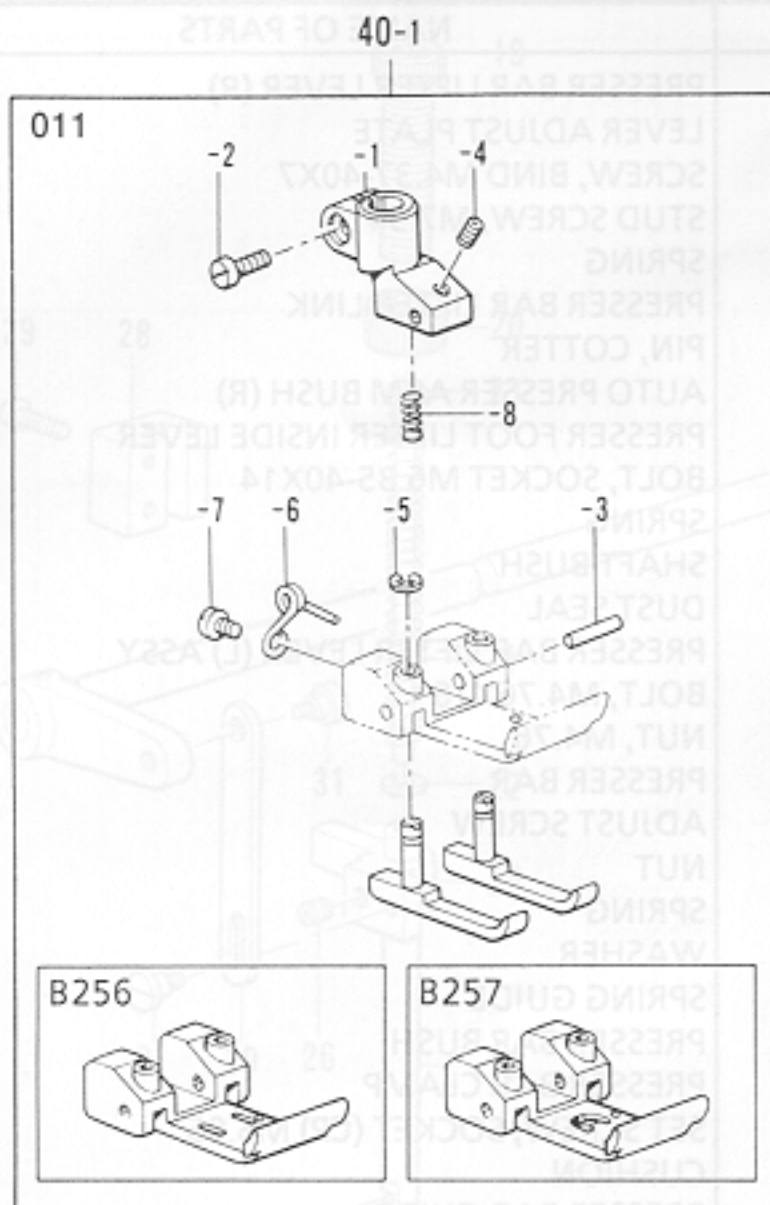

From the library of: DiamondNeedle-Corp

C2. 押工関係 / Presser foot mechanism / Stoffdrückerfuß /  
 Mécanisme de pied presseur / Mecanismo de la prensa tela

| REF.NO.  | CODE      | Q'TY | ヒンメイ          | NAME OF PARTS                | RM |
|--|-----------|------|---------------|------------------------------|----|
| <b>&lt;011&gt;</b>                                   |           |      |               |                              |    |
| 40-1   | ※         | 1    | オサエクミ         | PRESSER FOOT ASSY            |    |
| 40-1-1   | S08782101 | 1    | オサエシジタイ       | PRESSER FOOT BASE            |    |
| 40-1-2   | 100064005 | 1    | シメネジ3.57      | SCREW, M3.57                 |    |
| 40-1-3   | S08783101 | 1    | オサエピン         | PIN                          |    |
| 40-1-4   | S01374001 | 1    | トメネジ2.38クボミ   | SET SCREW, (CP) M2.38        |    |
| 40-1-5   | 048020342 | 2    | トメワE2         | RETAINING RING, E2           |    |
| 40-1-6   | S08784001 | 2    | オサエバネ         | SPRING                       |    |
| 40-1-7   | 062660512 | 2    | ナベコネジ318-40X5 | SCREW, PAN M3.18-40X5        |    |
| 40-1-8   | S08785001 | 1    | オシバネ          | SPRING                       |    |
| <b>&lt;033&gt;</b>                                   |           |      |               |                              |    |
| 40-2   | ※         | 1    | オサエクミ         | PRESSER FOOT ASSY            |    |
| 40-2-1   | S08782101 | 1    | オサエシジタイ       | PRESSER FOOT BASE            |    |
| 40-2-2   | 100064005 | 1    | シメネジ3.57      | SCREW, M3.57                 |    |
| 40-2-3   | S08783101 | 1    | オサエピン         | PIN                          |    |
| 40-2-4   | S01374001 | 1    | トメネジ2.38クボミ   | SET SCREW, (CP) M2.38        |    |
| 40-2-5   | 048020342 | 2    | トメワE2         | RETAINING RING, E2           |    |
| 40-2-6   | S08784001 | 2    | オサエバネ         | SPRING                       |    |
| 40-2-7   | 062660512 | 2    | ナベコネジ318-40X5 | SCREW, PAN M3.18-40X5        |    |
| 40-2-8   | S08785001 | 1    | オシバネ          | SPRING                       |    |
| <b>&lt;051,053,056,061&gt;</b>                       |           |      |               |                              |    |
| 40-3   | ※         | 1    | オサエクミ         | PRESSER FOOT ASSY            |    |
| 40-3-1   | S08782101 | 1    | オサエシジタイ       | PRESSER FOOT BASE            |    |
| 40-3-2   | 100064005 | 1    | シメネジ3.57      | SCREW, M3.57                 |    |
| 40-3-3   | S08783101 | 1    | オサエピン         | PIN                          |    |
| 40-3-4   | S01374001 | 1    | トメネジ2.38クボミ   | SET SCREW, (CP) M2.38        |    |
| 40-3-5   | 048020342 | 1    | トメワE2         | RETAINING RING, E2           |    |
| 40-3-6   | S08784001 | 1    | オサエバネ         | SPRING                       |    |
| 40-3-7   | 062660512 | 1    | ナベコネジ318-40X5 | SCREW, PAN M3.18-40X5        |    |
| 40-3-8   | S08785001 | 1    | オシバネ          | SPRING                       |    |
| <b>&lt;056&gt; &lt;幅広用 / FOR WIDE ELASTIC&gt;</b>    |           |      |               |                              |    |
| 36-3   | S28107101 | 1    | ヌノオサエ         | CLOTH PRESSER                |    |
| 37   | 062630412 | 2    | ナベコ238-56X4   | SCREW, PAN M2.38-56X4        |    |
| <b>&lt;056&gt; &lt;幅セマ用 / FOR NARROW ELASTIC&gt;</b> |           |      |               |                              |    |
| 36-4   | S28108101 | 1    | ヌノオサエ         | CLOTH PRESSER                |    |
| 37   | 062630412 | 2    | ナベコ238-56X4   | SCREW, PAN M2.38-56X4        |    |
| <b>&lt;B257-0V1&gt;</b>                              |           |      |               |                              |    |
| 40-4   | ※         | 1    | オサエクミ         | PRESSER FOOT ASSY            |    |
| 40-4-1   | S28558001 | 1    | ハシオサエクミ       | EDGE PRESSER ASSY            |    |
| 40-4-2   | S08806101 | 1    | オサエシジタイ       | PRESSER FOOT BASE            |    |
| 40-4-3   | 100064005 | 1    | シメネジ3.57      | SCREW, M3.57                 |    |
| 40-4-4   | S08807101 | 1    | オサエピン         | PIN                          |    |
| 40-4-5   | 048015346 | 1    | トメワE1.5       | RETAINING RING, E 1.5        |    |
| 40-4-6   | 146427001 | 1    | アナトメネジ3.18クボミ | SET SCREW, SOCKET (CP) M3.18 |    |
| 40-4-7   | S08808001 | 1    | ストツブネジ        | STOPPER SCREW                |    |
| 40-4-8   | 021660102 | 1    | ナツト1シユ3.18    | NUT, 1 M3.18                 |    |
| 40-4-9   | S08809001 | 1    | シメネジ2.38X3.5  | SCREW, M2.38X3.5             |    |
| 40-4-10  | S08810001 | 1    | オサエネジリバネ      | TWIST SPRING                 |    |
| 40-4-11  | 060630412 | 1    | バインド238-56X4  | SCREW, BIND M2.38-56X4       |    |
| 40-4-12  | S28560001 | 1    | ガイド           | GUIDE                        |    |
| 40-4-13  | 141544001 | 1    | シメネジ3.18      | SCREW, M3.18                 |    |
| 40-4-14  | S08812001 | 1    | オシバネ          | SPRING                       |    |

From the library of: Diamond Needle Corp

C2. 押工関係 / Presser foot mechanism / Stoffdrückerfuß /  
 Mécanisme de pied presseur / Mecanismo de la prensa tela

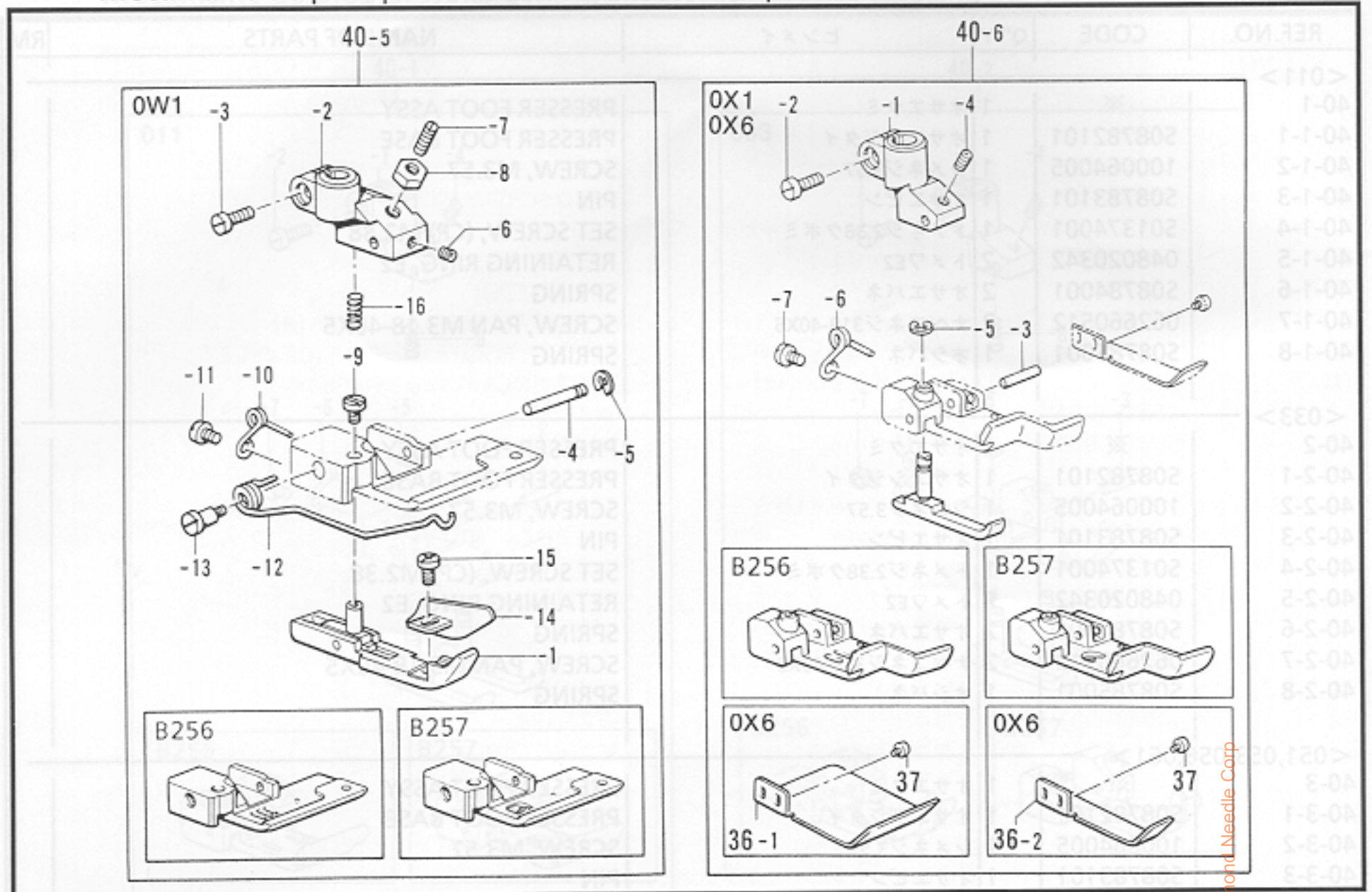

118-256,257-201

D. 針冷却関係 / Needle cooler / Nadelkühlungsvorrichtung /  
 Mécanisme du refroidisseur d'aiguille / Mecanismo del enfriador de aguja

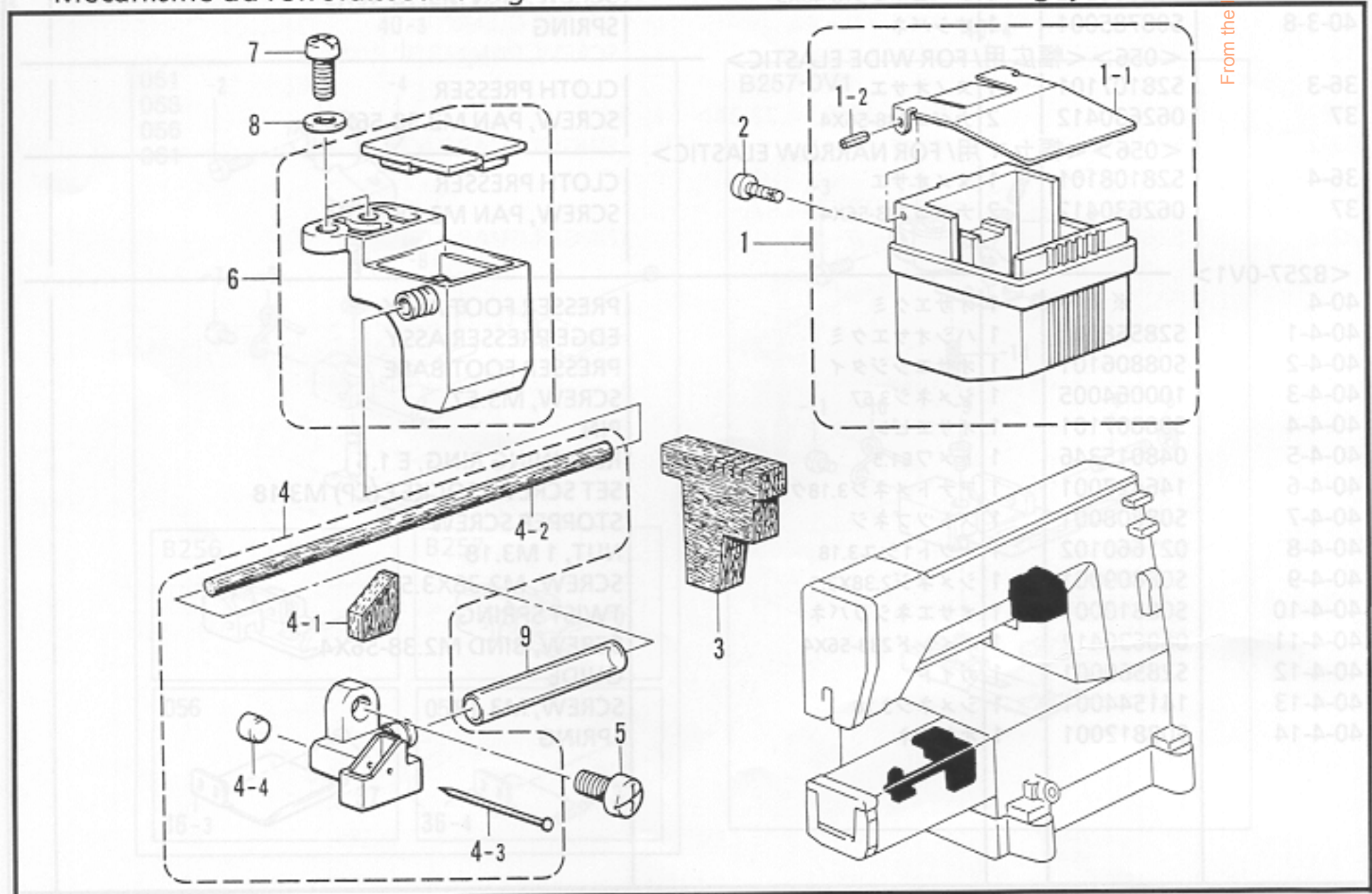

118-256,257-124

C2. 押工関係 / Presser foot mechanism / Stoffdrückerfuß /  
 Mécanisme de pied presseur / Mecanismo de la prensa tela

| REF.NO.                           | CODE      | Q'TY | ヒンメイ          | NAME OF PARTS                | RM |
|-----------------------------------|-----------|------|---------------|------------------------------|----|
| <0W1>                             |           |      |               |                              |    |
| 40-5                              | ※         | 1    | オサエクミ         | PRESSER FOOT ASSY            |    |
| 40-5-1                            | S28567001 | 1    | ハシオサエクミ       | EDGE PRESSER ASSY            |    |
| 40-5-2                            | S08806101 | 1    | オサエシジタイ       | PRESSER FOOT BASE            |    |
| 40-5-3                            | 100064005 | 1    | シメネジ3.57      | SCREW, M3.57                 |    |
| 40-5-4                            | S08807101 | 1    | オサエピン         | PIN                          |    |
| 40-5-5                            | 048015346 | 1    | トメワE1.5       | RETAINING RING, E 1.5        |    |
| 40-5-6                            | 146427001 | 1    | アナトメネジ3.18クボミ | SET SCREW, SOCKET (CP) M3.18 |    |
| 40-5-7                            | S08808001 | 1    | ストツブネジ        | STOPPER SCREW                |    |
| 40-5-8                            | 021660102 | 1    | ナット1シユ3.18    | NUT, 1 M3.18                 |    |
| 40-5-9                            | S08809001 | 1    | シメネジ2.38X3.5  | SCREW, M2.38X3.5             |    |
| 40-5-10                           | S08810001 | 1    | オサエネジリバネ      | TWIST SPRING                 |    |
| 40-5-11                           | 060630412 | 1    | バインド238-56X4  | SCREW, BIND M2.38-56X4       |    |
| 40-5-12                           | S28569001 | 1    | オサエバネ         | PRESSER SPRING               |    |
| 40-5-13                           | 155103001 | 1    | ダンネジ3.18      | STUD SCREW, M3.18            |    |
| 40-5-14                           | S28570001 | 1    | ガイドF          | GUIDE (F)                    |    |
| 40-5-15                           | 062670412 | 1    | ナベコ357-40X4   | SCREW, PAN M3.57-40X4        |    |
| 40-5-16                           | S08812001 | 1    | オシバネ          | SPRING                       |    |
| <0X1,0X6>                         |           |      |               |                              |    |
| 40-6                              | ※         | 1    | オサエクミ         | PRESSER FOOT ASSY            |    |
| 40-6-1                            | S28131001 | 1    | オサエシジタイ       | PRESSER FOOT BASE            |    |
| 40-6-2                            | 100064005 | 1    | シメネジ3.57      | SCREW, M3.57                 |    |
| 40-6-3                            | S08783101 | 1    | オサエピン         | PIN                          |    |
| 40-6-4                            | S01374001 | 1    | トメネジ2.38クボミ   | SET SCREW, (CP) M2.38        |    |
| 40-6-5                            | 048020342 | 1    | トメワE2         | RETAINING RING, E2           |    |
| 40-6-6                            | S08784001 | 1    | オサエバネ         | SPRING                       |    |
| 40-6-7                            | 062660512 | 1    | ナベコネジ318-40X5 | SCREW, PAN M3.18-40X5        |    |
| <0X6> <幅広用 / FOR WIDE ELASTIC>    |           |      |               |                              |    |
| 36-1                              | S28105001 | 1    | ヌノオサエ         | CLOTH PRESSER                |    |
| 37                                | 062630412 | 2    | ナベコ238-56X4   | SCREW, PAN M2.38-56X4        |    |
| <0X6> <幅セマ用 / FOR NARROW ELASTIC> |           |      |               |                              |    |
| 36-2                              | S28106001 | 1    | ヌノオサエ         | CLOTH PRESSER                |    |
| 37                                | 062630412 | 2    | ナベコ238-56X4   | SCREW, PAN M2.38-56X4        |    |

From the library of: Diamond Needle Corp

118-256,257-201

D. 針冷却関係 / Needle cooler / Nadelkühlungsvorrichtung /  
 Mécanisme du refroidisseur d'aiguille / Mecanismo del enfriador de aguja

| REF.NO. | CODE      | Q'TY | ヒンメイ             | NAME OF PARTS                   | RM |
|---------|-----------|------|------------------|---------------------------------|----|
| 1       | S08758009 | 1    | ハリイトレイキヤクタンククミ   | NEEDLE THREAD COOLER TANK ASSY  |    |
| 1-1     | S08760009 | 1    | ハリイトレイキヤクタンクフタ   | NEEDLE THREAD COOLER TANK COVER |    |
| 1-2     | 047200642 | 2    | スプリングピンAW2       | PIN, SPRING ROLL AW2            |    |
| 2       | 575456001 | 2    | +ナベPタイト3X10      | TAPTITE, PAN P M3X10            |    |
| 3       | S08761100 | 1    | ハリイトレイキヤクフェルト    | FELT                            |    |
| 4       | S28750001 | 1    | フェルトササエクミ        | FELT SUPPORT ASSY               |    |
| 4-1     | S28099000 | 1    | フェルトS            | FELT (S)                        |    |
| 4-2     | S28100000 | 1    | フェルト             | FELT                            |    |
| 4-3     | S02874001 | 1    | ムシピン             | PIN                             |    |
| 4-4     | 142274001 | 1    | メクラセン            | OIL CAP                         |    |
| 5       | 062680812 | 1    | ナベコ437-40X8      | SCREW, PAN M4.37-40X8           |    |
| 6       | S28101000 | 1    | ハリレイキヤクタンククミ     | NEEDLE COOLER TANK ASSY         |    |
| 7       | 062671012 | 2    | ナベコ357-40X10     | SCREW, PAN M3.57-40X10          |    |
| 8       | 105161003 | 2    | ザガネ              | WASHER                          |    |
| 9       | S28104000 | 1    | ビニルチューブ (L = 36) | OIL TUBE (L = 36)               |    |
| 49-2    | 047400842 | 1    | スプリングピンAW4x3     | SPRING PIN, AW4x3               |    |
| 50      | S28790001 | 1    | カド5ヤクシクククミ       | FEED SHAFT ARM ASSY             |    |
| 50-1    | S28198001 | 1    | カド5ヤクシクククミ       | DIFFERENTIAL FEED LINK          |    |
| 50-2    | S28186001 | 1    | アナトメネジ4.37クボミ    | SET SCREW, SOCKET (CP) M4.37    |    |
| 50-3    | 14680422  | 1    | アナトメネジ4.37クボミ    | SET SCREW, SOCKET (CP) M4.37    |    |

118-256,257-124

E1. 送り関係 / Feed mechanism / Transportvorrichtung /  
 Mécanisme de l'entraînement / Mecanismo de la alimentación

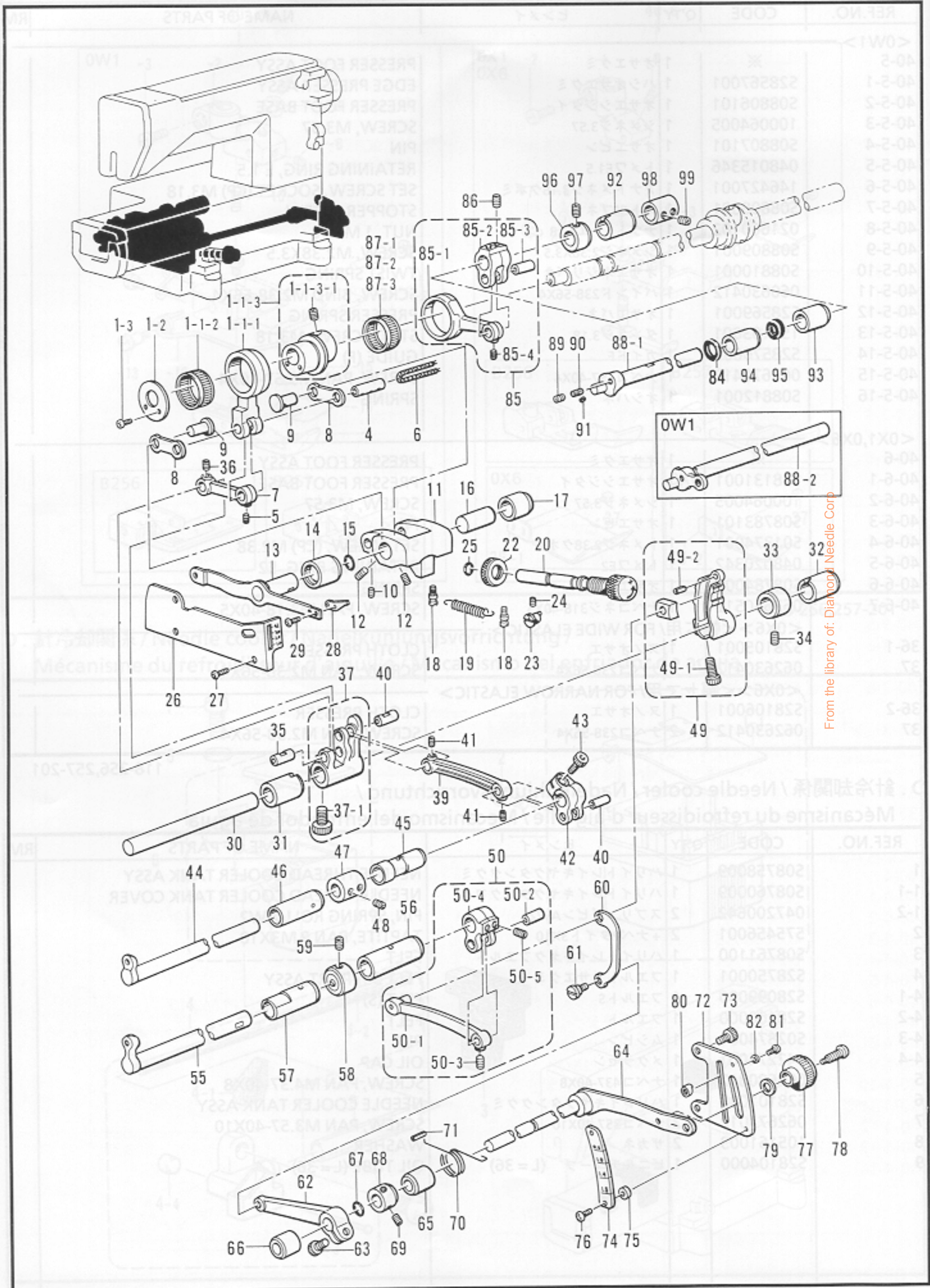

From the library of: Diamond Needle Corp

E1. 送り関係 / Feed mechanism / Transportvorrichtung / Mécanisme de l'entraînement / Mecanismo de la alimentación

| REF.NO. | CODE      | Q'TY | ヒンメイ           | NAME OF PARTS                    | RM |
|---------|-----------|------|----------------|----------------------------------|----|
| 1       | S28159001 | 1    | オクリロッドソウクミ     | FEED ROD SET                     |    |
| 1-1     | S28160001 | 1    | オクリロッドクミ       | FEED ROD ASSY                    |    |
| 1-1-1   | S28163001 | 1    | オクリロッド         | FEED ROD                         |    |
| 1-1-2   | S28164001 | 1    | ニードルジクウケ25     | NEEDLE ROLLER BEARING 25         |    |
| 1-1-3   | S28161001 | 1    | オクリヘンシンリンネジツキ  | FEED ECCENTRIC WHEEL WITH SCREW  |    |
| 1-1-3-1 | 014770622 | 2    | アナトメネジ6.35クボミ  | SET SCREW, SOCKET (CP) M6.35     |    |
| 1-2     | S28165001 | 1    | ロッドオサエイタ       | FEED ROD PRESSER PLATE           |    |
| 1-3     | 062670612 | 2    | ナベコ357-40X6    | SCREW, PAN M3.57-40X6            |    |
| 4       | S28166001 | 1    | オクリロッドピン       | PIN                              |    |
| 5       | 014680422 | 1    | アナトメネジ4.37クボミ  | SET SCREW, SOCKET (CP) M4.37     |    |
| 6       | 140418000 | 1    | クミヒモ (L = 56)  | WICK (L = 56)                    |    |
| 7       | S28167001 | 1    | オクリリンクL        | FEED LINK (L)                    |    |
| 8       | S28168001 | 1    | オクリリンクSクミ      | FEED LINK (S) ASSY               |    |
| 9       | S28170001 | 2    | オクリリンクSPIN     | FEED LINK (S) PIN                |    |
| 10      | 014680422 | 2    | アナトメネジ4.37クボミ  | SET SCREW, SOCKET (CP) M4.37     |    |
| 11      | S28171001 | 1    | オクリチヨウセツダイ     | FEED ADJUST BRACKET              |    |
| 12      | 148857001 | 4    | アナトメネジ6.35クボミ  | SET SCREW, SOCKET (CP) M6.35     |    |
| 13      | S28172001 | 1    | オクリチヨウセツレバー    | FEED ADJUST LEVER                |    |
| 14      | S28173000 | 1    | チヨウセツダイメタルL    | FEED ADJUST BRACKET BUSH (L)     |    |
| 15      | 081012070 | 1    | OリングP12        | O RING, P12                      |    |
| 16      | S28174001 | 1    | チヨウセツダイジク      | FEED ADJUST BRACKET SHAFT        |    |
| 17      | S28175000 | 1    | チヨウセツダイメタルR    | FEED ADJUST BRACKET BUSH (R)     |    |
| 18      | S28176001 | 2    | バネカケ           | SPRING HOOK                      |    |
| 19      | S28249001 | 1    | モドシバネ          | SPRING                           |    |
| 20      | S28177001 | 1    | オクリチヨウセツネジ     | FEED ADJUST SCREW                |    |
| 22      | S28179001 | 1    | チヨウセツネジツマミナツト  | FEED ADJUST SCREW KNOB NUT       |    |
| 23      | S28180001 | 1    | チヨウセツネジストツバ    | FEED ADJUST SCREW STOPPER        |    |
| 24      | 014680622 | 1    | アナトメネジ4.37クボミ  | SET SCREW, SOCKET (CP) M4.37     |    |
| 25      | 081007070 | 1    | OリングP7         | O RING, P7                       |    |
| 26      | S28181001 | 1    | オクリチヨウセツカバー    | FEED ADJUST COVER                |    |
| 27      | 106629002 | 3    | シメネジ4.37       | SCREW, M4.37                     |    |
| 28      | S28182001 | 1    | オクリピッチシジイタ     | FEED PITCH CONTROL PLATE         |    |
| 29      | 100105005 | 2    | シメネジ2.38       | SCREW, M2.38                     |    |
| 30      | S28183001 | 1    | オクリジク          | FEED SHAFT                       |    |
| 31      | S28184000 | 1    | オクリジクメタルL      | FEED SHAFT BUSH (L)              |    |
| 32      | S28185000 | 1    | オクリジクメタルR      | FEED SHAFT BUSH (R)              |    |
| 33      | 117671002 | 1    | セツトカラー         | SET COLLAR                       |    |
| 34      | 014770622 | 2    | アナトメネジ6.35クボミ  | SET SCREW, SOCKET (CP) M6.35     |    |
| 35      | S28186001 | 1    | ロッドピン          | ROD PIN                          |    |
| 36      | 014680422 | 1    | アナトメネジ4.37クボミ  | SET SCREW, SOCKET (CP) M4.37     |    |
| 37      | S28844001 | 1    | シュオクリウデクミ      | MAIN FEED ARM ASSY               |    |
| 37-1    | 018081622 | 1    | アナボルト8X16      | BOLT, SOCKET M8X16               |    |
| 39      | S28188001 | 1    | シュオクリリンク       | MAIN FEED LINK                   |    |
| 40      | S28186001 | 2    | ロッドピン          | ROD PIN                          |    |
| 41      | 014680422 | 2    | アナトメネジ4.37クボミ  | SET SCREW, SOCKET (CP) M4.37     |    |
| 42      | S28189001 | 1    | シュオクリジクウデ      | MAIN FEED SHAFT ARM              |    |
| 43      | 018771432 | 1    | アナボルト635-40X14 | BOLT, SOCKET M6.35-40X14         |    |
| 44      | S28190001 | 1    | シュオクリジク        | MAIN FEED SHAFT                  |    |
| 45      | S28191001 | 1    | シュオクリジクメタルR    | MAIN FEED SHAFT BUSH (R)         |    |
| 46      | S28192001 | 1    | シュオクリジクメタルL    | MAIN FEED SHAFT BUSH (L)         |    |
| 47      | S28193001 | 1    | セツトカラー         | SET COLLAR                       |    |
| 48      | 148857001 | 2    | アナトメネジ6.35クボミ  | SET SCREW, SOCKET (CP) M6.35     |    |
| 49      | S28194001 | 1    | サドウオクリウデコマクミ   | DIFFERENTIAL FEED ARM BLOCK ASSY |    |
| 49-1    | 018771432 | 1    | アナボルト635-40X14 | BOLT, SOCKET M6.35-40X14         |    |
| 49-2    | 047400842 | 1    | スプリングピンAW4X8   | PIN, SPRING ROLL AW4 x 8         |    |
| 50      | S28790001 | 1    | サドウオクリジクウデクミ   | DIFFERENTIAL FEED SHAFT ARM ASSY |    |
| 50-1    | S28198001 | 1    | サドウオクリリンク      | DIFFERENTIAL FEED LINK           |    |
| 50-2    | S28186001 | 1    | ロッドピン          | ROD PIN                          |    |
| 50-3    | 014680422 | 1    | アナトメネジ4.37クボミ  | SET SCREW, SOCKET (CP) M4.37     |    |

From the library of: Diamond Needle Corp



E1. 送り関係 / Feed mechanism / Transportvorrichtung /  
 Mécanisme de l'entraînement / Mecanismo de la alimentación

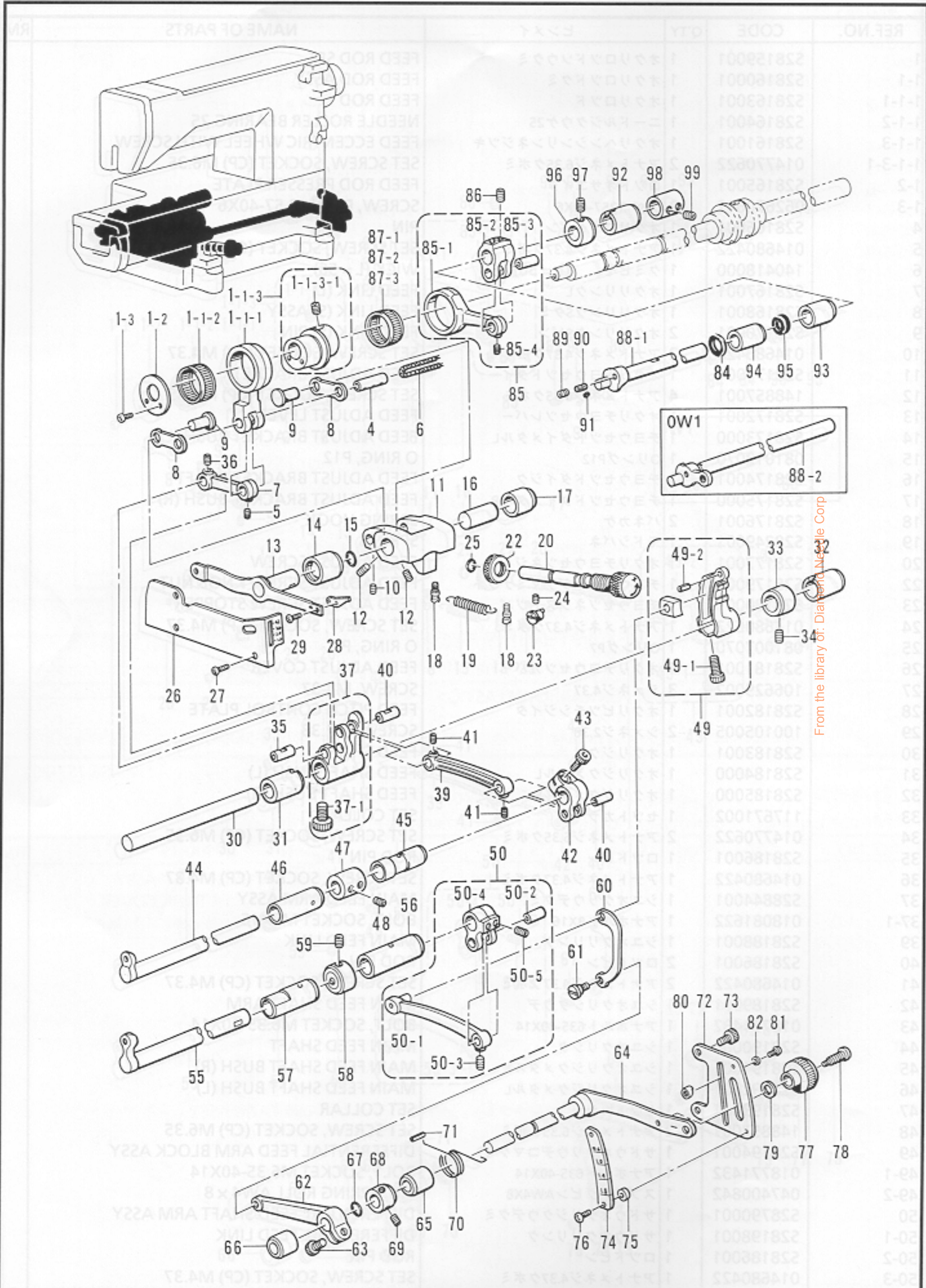

From the library of: Diaperoid Needle Corp

E1. 送り関係 / Feed mechanism / Transportvorrichtung / Mécanisme de l'entraînement / Mecanismo de la alimentación

| REF.NO. | CODE      | Q'TY | ヒンメイ               | NAME OF PARTS                       | RM |
|---------|-----------|------|--------------------|-------------------------------------|----|
| 50-4    | S28199001 | 1    | サドウオクリジクウデ         | DIFFERENTIAL FEED SHAFT ARM         |    |
| 50-5    | 014770622 | 2    | アナトメネジ6.35クボミ      | SET SCREW, SOCKET (CP) M6.35        |    |
| 55-1-1  | S28200001 | 1    | サドウオクリジク           | DIFFERENTIAL FEED SHAFT             |    |
| 56-1-2  | S28201001 | 1    | サドウオクリジクメタルR       | DIFFERENTIAL FEED SHAFT BUSH (R)    |    |
| 57-1-3  | S28202001 | 1    | サドウオクリジクメタルL       | DIFFERENTIAL FEED SHAFT BUSH (L)    |    |
| 58-2    | 117671002 | 1    | セットカラー             | SET COLLAR                          |    |
| 59      | 014770622 | 2    | アナトメネジ6.35クボミ      | SET SCREW, SOCKET (CP) M6.35        |    |
| 60      | S28203001 | 1    | サドウリンク             | DIFFERENTIAL FEED ADJUST LINK       |    |
| 61      | 155167001 | 1    | ダンネジ5.56           | STUD SCREW, M5.56                   |    |
| 62      | S28204001 | 1    | サドウリンクレバー          | DIFFERENTIAL FEED ADJUST LINK LEVER |    |
| 63      | 018771432 | 1    | アナボルト635-40X14     | BOLT, SOCKET M6.35-40X14            |    |
| 64      | S28205001 | 1    | サドウチヨウセツレバー        | DIFFERENTIAL FEED ADJUST LEVER      |    |
| 65      | S28206000 | 1    | サドウレバーメタルR         | DIFFERENTIAL FEED LEVER BUSH (R)    |    |
| 66      | S28207000 | 1    | サドウレバーメタルL         | DIFFERENTIAL FEED LEVER BUSH (L)    |    |
| 67      | 108549001 | 1    | Oリング               | O RING                              |    |
| 68      | 159491001 | 1    | セットカラー             | SET COLLAR                          |    |
| 69      | 014760622 | 2    | アナトメネジ5.95         | SET SCREW, SOCKET (CP) M5.95        |    |
| 70      | S28208001 | 1    | レバーバネ              | LEVER SPRING                        |    |
| 71      | 047501242 | 1    | スプリングピンAW5         | PIN, SPRING ROLL AW5                |    |
| 72      | S28209001 | 1    | サドウチヨウセツレバーイタ      | DIFFERENTIAL FEED LEVER PLATE       |    |
| 73      | 018061022 | 2    | アナボルト6X10          | BOLT, SOCKET M6X10                  |    |
| 74      | S28210001 | 1    | サドウリヨウメモリアタ        | DIFFERENTIAL STITCH CONTROL         |    |
| 75      | S28248001 | 2    | カラー                | COLLAR                              |    |
| 76      | 062670812 | 2    | ナベコ3.57-40X8       | SCREW, PAN M3.57-40X8               |    |
| 77      | S20549101 | 1    | セットネジツマミ           | SET SCREW KNOB                      |    |
| 78      | S20550002 | 1    | セットネジ              | SET SCREW                           |    |
| 79      | S20560001 | 1    | サラバネザガネ            | SPRING WASHER                       |    |
| 80      | S25818002 | 2    | チヨウセツレバーストツパ       | STOPPER FOR FEED ADJUST LEVER       |    |
| 81      | 062350616 | 2    | ナベコM3.5X6          | SCREW, PAN M3.5X6                   |    |
| 82      | 105161004 | 2    | ザガネ                | WASHER                              |    |
| 84      | 148559100 | 1    | ゴム                 | RUBBER                              |    |
| 85      | S28211001 | 1    | ジヨウゲオクリロッドクミ       | FEED LIFTING ROD ASSY               |    |
| 85-1    | S28212001 | 1    | ジヨウゲオクリロッド         | FEED LIFTING ROD                    |    |
| 85-2    | S28213001 | 1    | ジヨウゲオクリウデ          | FEED LIFTING ARM                    |    |
| 85-3    | S28186001 | 1    | ロッドピン              | ROD PIN                             |    |
| 85-4    | 014680422 | 1    | アナトメネジ4.37クボミ      | SET SCREW, SOCKET (CP) M4.37        |    |
| 86      | 014770622 | 2    | アナトメネジ6.35クボミ      | SET SCREW, SOCKET (CP) M6.35        |    |
| 87-1    | S20500001 | 1    | ニードルジクウケ24         | NEEDLE ROLLER BEARING 24            |    |
| 87-2    | S20500002 | 1    | ニードルジクウケ24         | NEEDLE ROLLER BEARING 24            |    |
| 87-3    | S20500003 | 1    | ニードルジクウケ24         | NEEDLE ROLLER BEARING 24            |    |
| 88-1    | S28214001 | 1    | ジヨウゲオクリジク          | FEED LIFTING SHAFT                  |    |
| 89      | 153675001 | 1    | アナトメネジ4.37         | SET SCREW, SOCKET M4.37             |    |
| 90      | S28845000 | 1    | フェルト               | FELT                                |    |
| 91      | S12718000 | 1    | ケミカルフェルト           | CHEMICAL FELT                       |    |
| 92      | S28216000 | 1    | ジヨウゲジクメタルR         | FEED LIFTING SHAFT BUSH (R)         |    |
| 93      | S28217000 | 1    | ジヨウゲジクメタルM         | FEED LIFTING SHAFT BUSH (M)         |    |
| 94      | S28218001 | 1    | ジヨウゲジクメタルL         | FEED LIFTING SHAFT BUSH (L)         |    |
| 95      | S12827000 | 1    | ダストシール             | DUST SEAL                           |    |
| 96      | 159491001 | 1    | セットカラー             | SET COLLAR                          |    |
| 97      | 014760622 | 2    | アナトメネジ5.95         | SET SCREW, SOCKET (CP) M5.95        |    |
| 98      | S28193001 | 1    | セットカラー             | SET COLLAR                          |    |
| 99      | 148857001 | 2    | アナトメネジ6.35クボミ      | SET SCREW, SOCKET (CP) M6.35        |    |
| 88-2    | S28215001 | 1    | <0W1><br>ジヨウゲオクリジク | FEED LIFTING SHAFT                  |    |

From the library of: Diamond Needle Corp

E2. 送り関係 / Feed mechanism / Transportvorrichtung /  
 Mécanisme de l'entraînement / Mecanismo de la alimentación

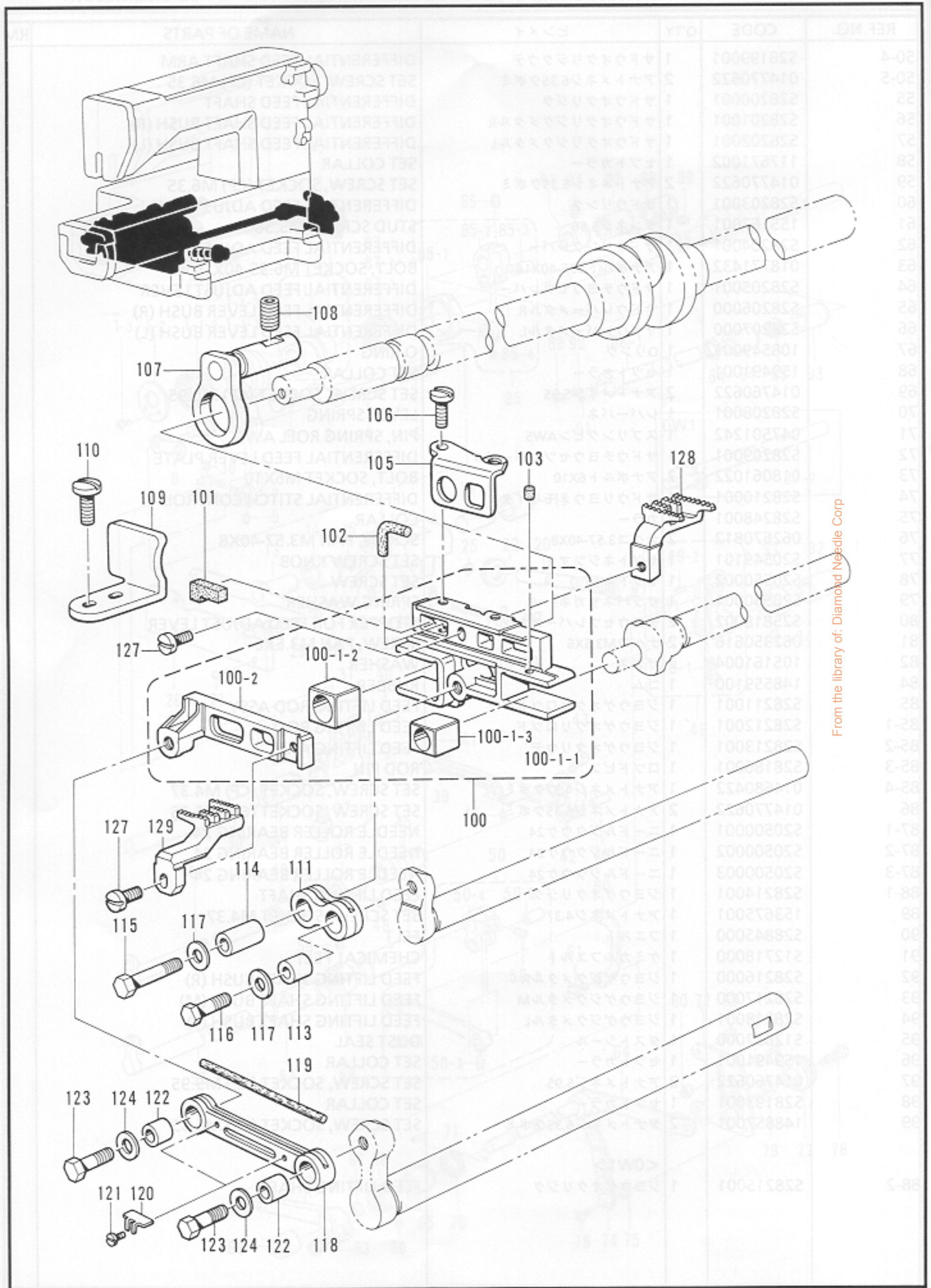

From the library of: Diamond Needle Corp

E2. 送り関係 / Feed mechanism / Transportvorrichtung /  
 Mécanisme de l'entraînement / Mecanismo de la alimentación

| REF.NO. | CODE      | Q'TY | ヒンメイ          | NAME OF PARTS                | RM |
|---------|-----------|------|---------------|------------------------------|----|
| 100     | S28793001 | 1    | オクリダイクミ       | FEED BAR ASSY                |    |
| 100-1   | S28219001 | 1    | オクリダイカクゴマクミ   | FEED BAR SLIDE BLOCK ASSY    |    |
| 100-1-1 | S28220001 | 1    | シユオクリダイ       | MAIN FEED BAR                |    |
| 100-1-2 | S28221000 | 1    | オクリダイカクゴマB    | FEED BAR SLIDE BLOCK (B)     |    |
| 100-1-3 | S28222000 | 1    | オクリダイカクゴマF    | FEED BAR SLIDE BLOCK (F)     |    |
| 100-2   | S28225001 | 1    | サドウオクリダイ      | DIFFERENTIAL FEED BAR        |    |
| 101     | S28223000 | 1    | シユオクリダイフェルト   | MAIN FEED BAR FELT           |    |
| 102     | S05246000 | 1    | フェルト          | FELT                         |    |
| 103     | S28224000 | 1    | フェルトS         | FELT (S)                     |    |
| 105     | S28226001 | 1    | サドウオクリダイアンナイ  | DIFFERENTIAL FEED BAR GUIDE  |    |
| 106     | 112751003 | 2    | シメネジ3.57      | SCREW, M3.57                 |    |
| 107     | S28227001 | 1    | オクリダイアンナイR    | FEED BAR GUIDE (R)           |    |
| 108     | 014780622 | 1    | アナトメネジ6.35クボミ | SET SCREW, SOCKET (CP) M6.35 |    |
| 109     | S28228001 | 1    | オクリダイアンナイL    | FEED BAR GUIDE (L)           |    |
| 110     | 100644005 | 2    | シメネジ4.37      | SCREW, M4.37                 |    |
| 111     | S28229000 | 1    | シユオクリジクリンク    | MAIN FEED SHAFT LINK         |    |
| 113     | S28232001 | 1    | リンクカラーS       | LINK COLLAR (S)              |    |
| 114     | S28233001 | 1    | リンクカラーL       | LINK COLLAR (L)              |    |
| 115     | 148186001 | 1    | ボルト4.76       | BOLT, M4.76                  |    |
| 116     | S28843001 | 1    | ボルト4.76       | BOLT, M4.76                  |    |
| 117     | 155157001 | 2    | ザガネ           | WASHER                       |    |
| 118     | S28234000 | 1    | サドウオクリジクリンク   | DIFFERENTIAL FEED SHAFT LINK |    |
| 119     | S28235000 | 1    | リンクフェルトL      | LINK FELT (L)                |    |
| 120     | S28231000 | 2    | フェルトオサエ       | FELT SUPPORT                 |    |
| 121     | 060630412 | 2    | バインド238-56X4  | SCREW, BIND M2.38-56X4       |    |
| 122     | S28232001 | 2    | リンクカラーS       | LINK COLLAR (S)              |    |
| 123     | S28843001 | 2    | ボルト4.76       | BOLT, M4.76                  |    |
| 124     | 155157001 | 2    | ザガネ           | WASHER                       |    |
| 127     | S28236001 | 2    | シメネジ3.57      | SCREW, M3.57                 |    |
| 128     | ※         | 1    | シユオクリバ        | MAIN FEED DOG                |    |
| 129     | ※         | 1    | サドウオクリバ       | DIFFERENTIAL FEED DOG        |    |

From the library of: Diamond Needle Corp

Select parts marked with a star (★) according to the index of the timing belt. (Refer to timing belt replacement in the instruction manual.)

Die mit dem Zeichen (★) markierten Teile entsprechend dem an der Oberseite der Abbildung angegebenen Index auswählen. (Siehe Ersetzen des Synchronriemens in der Bedienungsanleitung.)

Selectionner les pièces marquées par une étoile (★) selon l'index situé sur le plateau du bras. (Se reporter à la section du manuel à propos des conseils concernant le remplacement de la courroie de synchronisation.)

Las piezas marcadas con un asterisco (★) se deben seleccionar de acuerdo al índice de la parte superior de la mesa del brazo. (Consultar la sección sobre el cambio de la correa de distribución en el manual de instrucciones.)

F. 下軸関係 / Lower shaft mechanism / Untere Welle /  
 Mécanisme de l'arbre inférieur / Mecanismo del eje inferior

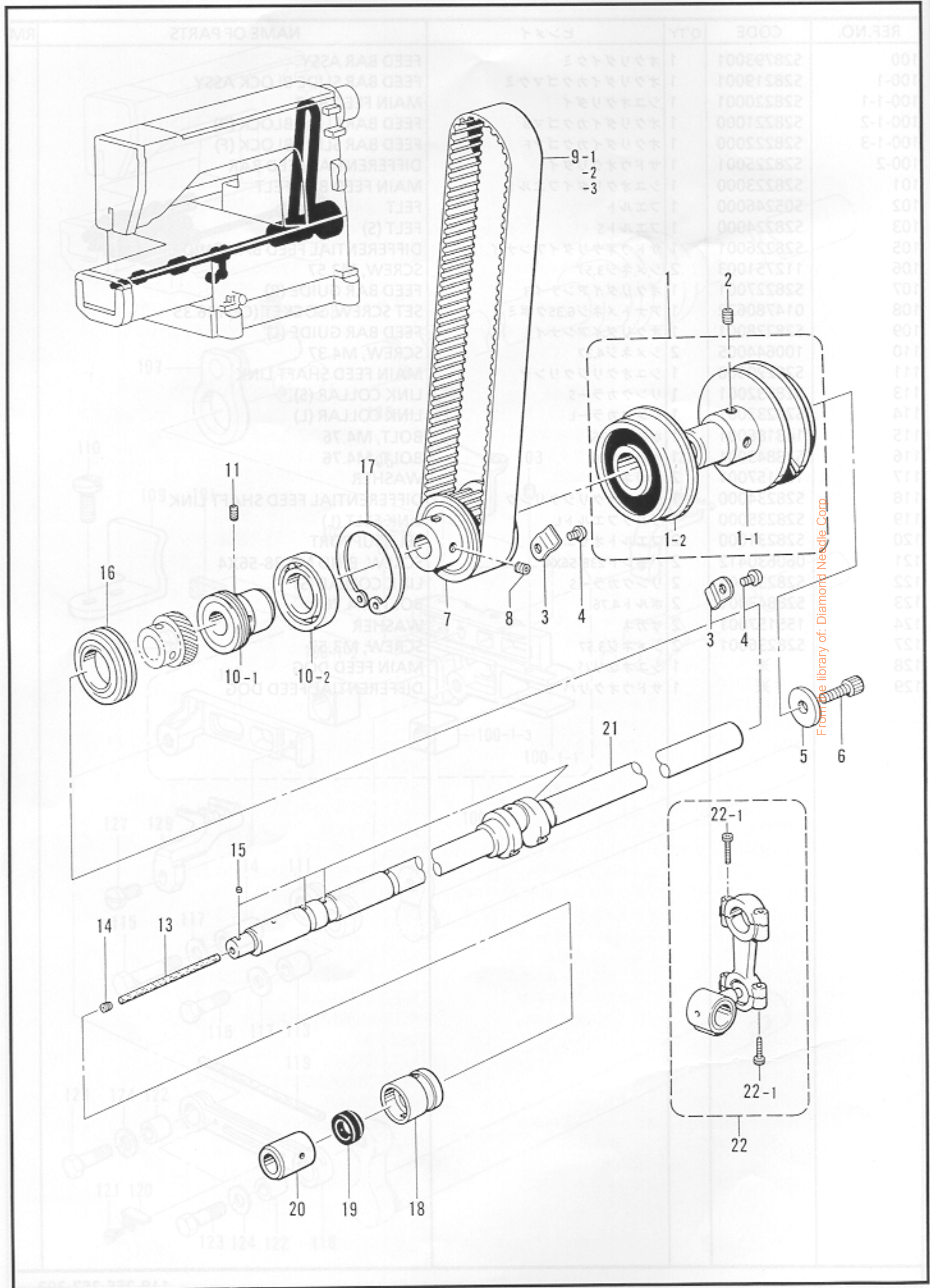

From the library of: Diamond Needle Corp

F. 下軸関係 / Lower shaft mechanism / Untere Welle /  
 Mécanisme de l'arbre inférieur / Mecanismo del eje inferior

| REF.NO. | CODE        | Q'TY | ヒンメイ            | NAME OF PARTS                | RM |
|---------|-------------|------|-----------------|------------------------------|----|
| 1       | S08889101   | 1    | Vベルトプーリクミ       | V-BELT PULLEY ASSY           |    |
| 1-1     | S08890001   | 1    | Vベルトプーリ         | V-BELT PULLEY                |    |
| 1-2     | S14622001   | 1    | タマジクウケ6304VV    | BALL BEARING, 6304VV         |    |
| 2       | 014780622   | 2    | アナトメネジ6.35クボミ   | SET SCREW, SOCKET (CP) M6.35 |    |
| 3       | 153734001   | 2    | アームササエイタバネ      | PLATE SPRING                 |    |
| 4       | 062680612   | 2    | ナベコ4.37-40X6    | SCREW, PAN M4.37-40X6        |    |
| 5       | 154886001   | 1    | ザガネ             | WASHER                       |    |
| 6       | 018771432   | 1    | アナボルト6.35-40X14 | BOLT, SOCKET M6.35-40X14     |    |
| 7       | S08892001   | 1    | タイミングプーリDクミ     | TIMING PULLEY (D) ASSY       |    |
| 8       | 014770622   | 2    | アナトメネジ6.35クボミ   | SET SCREW, SOCKET (CP) M6.35 |    |
| 9-1     | ★ S12806001 | 1    | タイミングベルト        | TIMING BELT                  |    |
| 9-2     | ★ S12806002 | 1    | タイミングベルト        | TIMING BELT                  |    |
| 9-3     | ★ S12806003 | 1    | タイミングベルト        | TIMING BELT                  |    |
| 10      | S28363001   | 1    | タマジクウケクミ        | BALL BEARING ASSY            |    |
| 10-1    | S28364001   | 1    | ウーム             | WORM                         |    |
| 10-2    | S28365001   | 1    | タマジクウケ6005DU    | BALL BEARING, 6005DU         |    |
| 11      | 014770622   | 2    | アナトメネジ6.35クボミ   | SET SCREW, SOCKET (CP) M6.35 |    |
| 13      | S28372000   | 1    | フェルト            | FELT                         |    |
| 14      | 153675001   | 1    | アナトメネジ4.37      | SET SCREW, SOCKET M4.37      |    |
| 15      | S12718000   | 4    | ケミカルフェルト        | CHEMICAL FELT                |    |
| 16      | S28373001   | 1    | タマジクウケ6203      | BALL BEARING, 6203           |    |
| 17      | 048470242   | 1    | トメワアナヨウC47      | RETAINING RING, C47          |    |
| 18      | S28374000   | 1    | シタジクメタルR        | LOWER SHAFT BUSH (R)         |    |
| 19      | S28375000   | 1    | ダストシール          | DUST SEAL                    |    |
| 20      | S28376000   | 1    | シタジクメタルL        | LOWER SHAFT BUSH (L)         |    |
|         |             |      | <アカ>            | <RED>                        |    |
| 21      | S28367011   | 1    | シタジク            | LOWER SHAFT                  |    |
| 22      | S28368011   | 1    | ルーパロツドクミ        | LOOPER ROD ASSY              |    |
| 22-1    | 018401422   | 4    | アナボルト4X14       | BOLT, SOCKET M4X14           |    |
|         |             |      | <アオ>            | <BLUE>                       |    |
| 21      | S28367012   | 1    | シタジク            | LOWER SHAFT                  |    |
| 22      | S28368012   | 1    | ルーパロツドクミ        | LOOPER ROD ASSY              |    |
| 22-1    | 018401422   | 4    | アナボルト4X14       | BOLT, SOCKET M4X14           |    |

From the library of: Diamond Needle Corp

★印はアームベッド上面のテーキンに合わせてご選択下さい。(取扱説明書タイミングベルト交換の仕方を  
 ご参照ください。)

Select parts marked with a star (★) according to the index on the arm bed top. (Refer to timing belt  
 replacement in the instruction manual.)

Die mit dem Zeichen (★) markierten Teile entsprechend dem an der Oberseite des Armbetts angegebenen  
 Index auswählen. (Siehe Ersetzen des Synchronriemens in der Bedienungsanleitung.)

Sélectionner les pièces indiquées par une étoile (★) selon l'index situé sur le plateau du bras. (Se reporter à la  
 section du manuel d'instructions concernant le remplacement de la courroie de synchronisation.)

Las piezas marcadas con un asterisco (★) se deben seleccionar de acuerdo al índice de la parte superior de la  
 mesa del brazo. (Consultar la sección sobre el cambio de la correa de distribución en el manual de  
 instrucciones.)

G. ルーパー関係 / Looper mechanism / Greifer /  
 Mécanisme des griffes / Mecanismo del presilladora

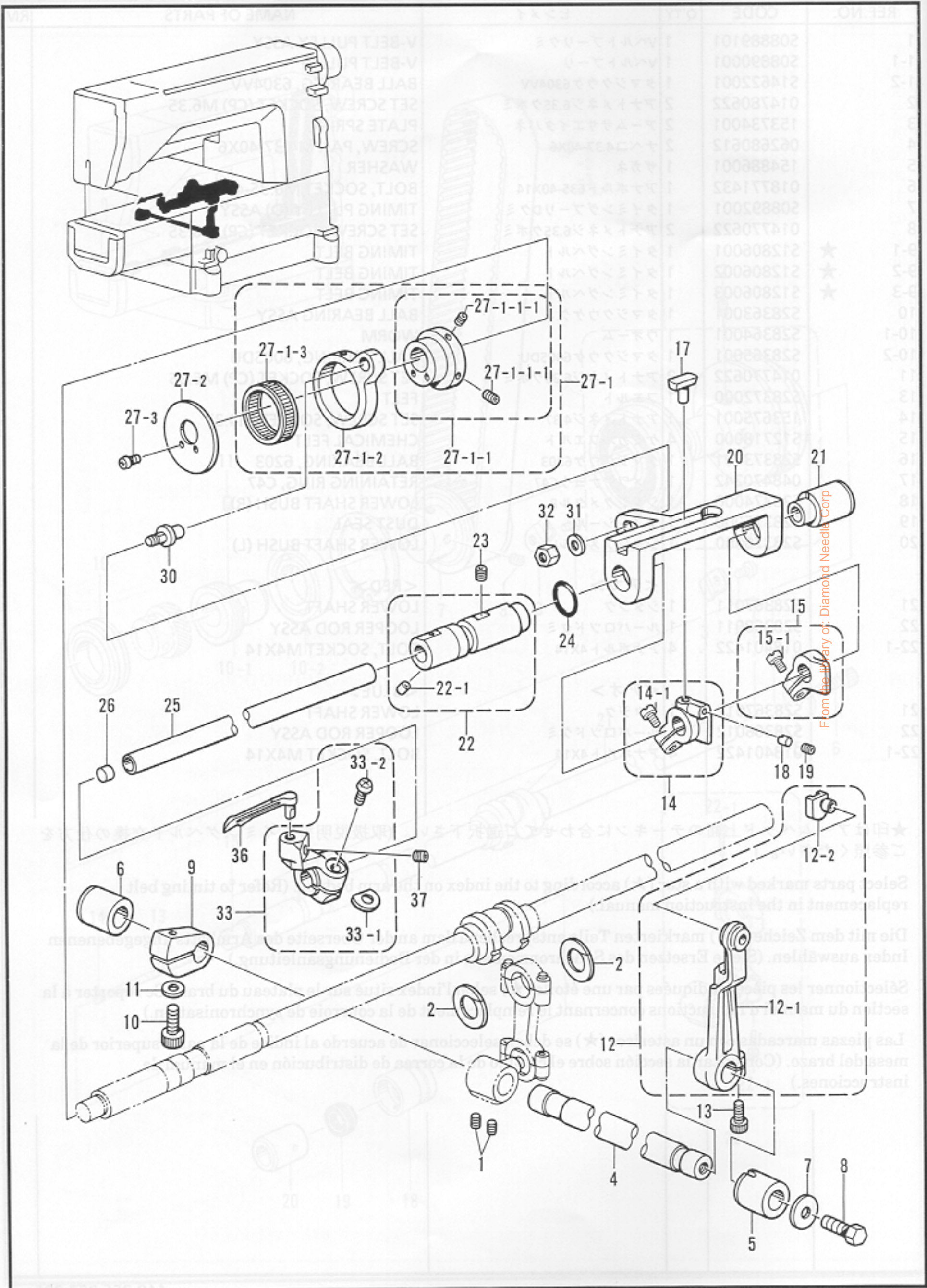

G. ルーパー関係 / Looper mechanism / Greifer /  
Mécanisme des griffes / Mecanismo del presilladora

| REF.NO.  | CODE      | Q'TY | ヒンメイ            | NAME OF PARTS                     | RM |
|----------|-----------|------|-----------------|-----------------------------------|----|
| 1        | 014770622 | 2    | アナトメネジ6.35クボミ   | SET SCREW, SOCKET (CP) M6.35      |    |
| 2        | S20598000 | 2    | ロッドフレドメ         | ROD STOPPER                       |    |
| 4        | S28377001 | 1    | ルーバジク           | LOOPER SHAFT                      |    |
| 5        | S28184000 | 1    | オクリジクメタルL       | FEED SHAFT BUSH (L)               |    |
| 6        | S28842001 | 1    | ルーバジクメタルB       | LOOPER SHAFT BUSH (B)             |    |
| 7        | 151090001 | 1    | スラストザガネ         | THRUST WASHER                     |    |
| 8        | 017771412 | 1    | ボルト6.35X14      | BOLT, M6.35X14                    |    |
| 9        | S28848000 | 1    | バランス            | BALANCE                           |    |
| 10       | 018062022 | 1    | アナボルト6X20       | BOLT, SOCKET M6X20                |    |
| 11       | 155559001 | 1    | ヒラザガネ           | WASHER, PLAIN                     |    |
| 12       | S28823001 | 1    | ルーバヨウドウウデクミ     | LOOPER DRIVING ARM ASSY           |    |
| 12-1     | S28824001 | 1    | ルーバヨウドウウデ       | LOOPER DRIVING ARM                |    |
| 12-2     | S28825001 | 1    | ヨウドウウデカクゴマ      | DRIVING ARM SLIDE BLOCK           |    |
| 13       | 018771432 | 1    | アナボルト6.35-40X14 | BOLT, SOCKET M6.35-40X14          |    |
| 14       | S28826001 | 1    | スライダホルダクミ       | SLIDER HOLDER ASSY                |    |
| 14-1     | 100064005 | 1    | シメネジ3.57        | SCREW, M3.57                      |    |
| 15       | S28828001 | 1    | カクゴマホルダクミ       | SLIDE BLOCK HOLDER ASSY           |    |
| 15-1     | 100064005 | 1    | シメネジ3.57        | SCREW, M3.57                      |    |
| 17       | S28383001 | 1    | スライダー           | SLIDER                            |    |
| 18       | S28384001 | 1    | スライダーオシ         | SLIDER PUSH                       |    |
| 19       | 014680422 | 1    | アナトメネジ4.37クボミ   | SET SCREW, SOCKET (CP) M4.37      |    |
| 20       | S28385000 | 1    | ルーバボウガイド        | LOOPER BAR GUIDE                  |    |
| 21       | S28386001 | 1    | ルーバボウメタルR       | LOOPER BAR BUSH (R)               |    |
| 22       | S28387001 | 1    | ルーバボウメタルLクミ     | LOOPER BAR BUSH (L) ASSY          |    |
| 22-1     | 047402042 | 1    | スプリングピンA4       | PIN, SPRING ROLL A4               |    |
| 23       | 014780622 | 1    | アナトメネジ6.35クボミ   | SET SCREW, SOCKET (CP) M6.35      |    |
| 24       | 081012070 | 1    | OリングP12         | O RING, P12                       |    |
| 25       | S28389001 | 1    | ルーバボウ           | LOOPER BAR                        |    |
| 26       | S28869000 | 1    | メクラセン           | OIL CAP                           |    |
| 27       | S28795001 | 1    | ゼンゴロツドソウクミ      | LONGITUDINAL FEED ROD SET         |    |
| 27-1     | S28390001 | 1    | ルーバゼンゴロツドクミ     | LOOPER LONGITUDINAL FEED ROD ASSY |    |
| 27-1-1   | S28391001 | 1    | ルーバヘンシンリンネジツキ   | LOOPER ECCENTRIC WHEEL WITH SCREW |    |
| 27-1-1-1 | 014680622 | 2    | アナトメネジ4.37クボミ   | SET SCREW, SOCKET (CP) M4.37      |    |
| 27-1-2   | S28393001 | 1    | ルーバゼンゴロツド       | LOOPER LONGITUDINAL FEED ROD      |    |
| 27-1-3   | S12915001 | 1    | ニードルジクウケ25      | NEEDLE ROLLER BEARING 25          |    |
| 27-2     | S28165001 | 1    | ロツドオサエイタ        | FEED ROD PRESSER PLATE            |    |
| 27-3     | 062670612 | 2    | ナベコ357-40X6     | SCREW, PAN M3.57-40X6             |    |
| 30       | S28394001 | 1    | ゼンゴロツドピン        | PIN                               |    |
| 31       | 148847001 | 1    | ザガネ             | WASHER                            |    |
| 32       | 110161006 | 1    | ナツト4.76         | NUT, M4.76                        |    |
| 33       | S28885001 | 1    | ルーバホルダクミ        | LOOPER HOLDER ASSY                |    |
| 33-1     | S28381000 | 1    | スペーサ            | SPACER                            |    |
| 33-2     | 062671012 | 1    | ナベコ357-40X10    | SCREW, PAN M3.57-40X10            |    |
| 36       | S28396001 | 1    | ルーバ             | LOOPER                            |    |
| 37       | 014680422 | 1    | アナトメネジ4.37クボミ   | SET SCREW, SOCKET (CP) M4.37      |    |



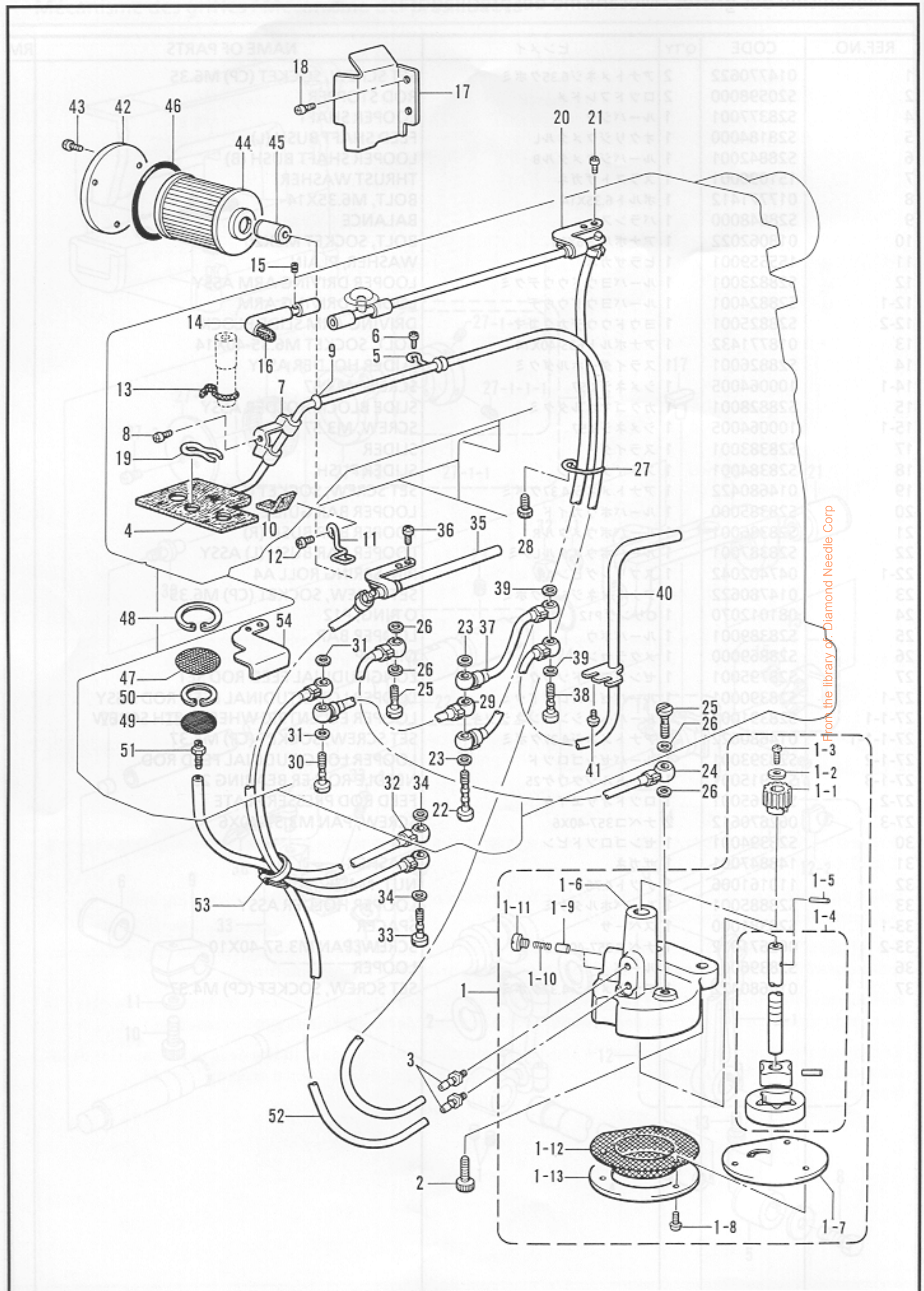

From the library of: Diamond Needle Corp

H. 給油潤滑関係 / Lubrication / Schmierung / Lubrification / Lubricación

| REF.NO. | CODE      | Q'TY | ヒンメイ              | NAME OF PARTS                | RM |
|---------|-----------|------|-------------------|------------------------------|----|
| 1       | S28397101 | 1    | トロコイドポンプクミ        | PUMP ASSY                    |    |
| 1-1     | 144619000 | 1    | ウオームホイール          | WORM WHEEL                   |    |
| 1-2     | 025350332 | 1    | ヒラザガネダイ3.5        | WASHER, PLAIN L 3.5          |    |
| 1-3     | 062670812 | 1    | ナベコ3.57-40X8      | SCREW, PAN M3.57-40X8        |    |
| 1-4     | S28398001 | 1    | ポンプロータークミ         | PUMP INNER ROTER ASSY        |    |
| 1-5     | 144622001 | 1    | ミゾツキピンEガタ         | DOWEL PIN (E)                |    |
| 1-6     | S28400100 | 1    | ポンプケース            | PUMP CASE                    |    |
| 1-7     | 147527000 | 1    | ポンプフタ             | PUMP COVER                   |    |
| 1-8     | 062671012 | 3    | ナベコ357-40X10      | SCREW, PAN M3.57-40X10       |    |
| 1-9     | 144875001 | 2    | プランジャー            | PLUNGER                      |    |
| 1-10    | 144876001 | 2    | プランジャーバネ          | PLUNGER SPRING               |    |
| 1-11    | 112467002 | 2    | シメネジ6.35          | SCREW, M6.35                 |    |
| 1-12    | 147528100 | 1    | ロカモウ              | OIL FILTER                   |    |
| 1-13    | 147529000 | 1    | ロカモウオサエ           | OIL FILTER FLANGE            |    |
| 2       | 018061622 | 2    | アナボルト6X16         | BOLT, SOCKET M6X16           |    |
| 3       | 142359001 | 2    | オイルクチ             | OIL FEEDING PIPE             |    |
| 4       | S28401001 | 1    | チューブクミ            | OIL TUBE ASSY                |    |
| 5       | 112743001 | 1    | クミヒモササエ           | WICK SUPPORT                 |    |
| 6       | 062670612 | 1    | ナベコ357-40X6       | SCREW, PAN M3.57-40X6        |    |
| 7       | 151429001 | 1    | チューブホルダ           | TUBE HOLDER                  |    |
| 8       | 062670612 | 1    | ナベコ357-40X6       | SCREW, PAN M3.57-40X6        |    |
| 9       | 118770001 | 1    | パツキン              | PACKING                      |    |
| 10      | S08943000 | 1    | カクゴマフェルト          | FELT                         |    |
| 11      | S08944001 | 1    | フェルトオサエ           | FELT SUPPORT                 |    |
| 12      | 062670612 | 1    | ナベコ357-40X6       | SCREW, PAN M3.57-40X6        |    |
| 13      | 157840000 | 1    | クミヒモ3X3 (L = 100) | WICK 3X3 (L = 100)           |    |
| 14      | S08945001 | 1    | オイルパイプ            | OIL PIPE                     |    |
| 15      | 014680622 | 1    | アナトメネジ4.37クボミ     | SET SCREW, SOCKET (CP) M4.37 |    |
| 16      | S08946000 | 1    | フェルト              | FELT                         |    |
| 17      | S08947001 | 1    | オイルヨケイタ           | OIL STOPPER PLATE            |    |
| 18      | 062670612 | 2    | ナベコ357-40X6       | SCREW, PAN M3.57-40X6        |    |
| 19      | 145737001 | 1    | フェルトオサエ           | FELT SUPPORT                 |    |
| 20      | S08948001 | 1    | ロツドオイルパイプUクミ      | MAIN OIL PIPE (U) ASSY       |    |
| 21      | 062670612 | 2    | ナベコ357-40X6       | SCREW, PAN M3.57-40X6        |    |
| 22      | 112351001 | 1    | ハイユパイプネジ          | OIL FEEDING PIPE SCREW       |    |
| 23      | 159476000 | 2    | ザガネ               | WASHER                       |    |
| 24      | S12846001 | 1    | ビニルチューブクミ         | OIL TUBE ASSY                |    |
| 25      | 112359001 | 2    | ハイユパイプツギテネジ       | OIL FEEDING PIPE JOINT SCREW |    |
| 26      | 159476000 | 4    | ザガネ               | WASHER                       |    |
| 27      | S28405001 | 1    | チューブガイド           | TUBE GUIDE                   |    |
| 28      | 018060822 | 1    | アナボルト6X8          | BOLT, SOCKET M6X8            |    |
| 29      | S28846001 | 1    | ビニルチューブクミ         | OIL TUBE ASSY                |    |
| 30      | 112364001 | 1    | ハイユパイプツギテネジ       | OIL FEEDING PIPE JOINT SCREW |    |
| 31      | 159476000 | 2    | ザガネ               | WASHER                       |    |
| 32      | S28403001 | 1    | ビニルチューブクミ         | OIL TUBE ASSY                |    |
| 33      | 112364001 | 1    | ハイユパイプツギテネジ       | OIL FEEDING PIPE JOINT SCREW |    |
| 34      | 159476000 | 2    | ザガネ               | WASHER                       |    |
| 35      | S28406001 | 1    | ロツドオイルパイプDクミ      | MAIN OIL PIPE (D) ASSY       |    |
| 36      | 062670612 | 2    | ナベコ357-40X6       | SCREW, PAN M3.57-40X6        |    |
| 37      | S28409001 | 1    | ビニルチューブクミ         | OIL TUBE ASSY                |    |
| 38      | 112364001 | 1    | ハイユパイプツギテネジ       | OIL FEEDING PIPE JOINT SCREW |    |
| 39      | 159476000 | 2    | ザガネ               | WASHER                       |    |
| 40      | S28411001 | 1    | ギアキユウユパイプクミ       | GEAR OIL PIPE ASSY           |    |
| 41      | 062680812 | 2    | ナベコ437-40X8       | SCREW, PAN M4.37-40X8        |    |
| 42      | S12987001 | 1    | オイルフィルターフタ        | OIL FILTER CAP               |    |
| 43      | 062680812 | 3    | ナベコ437-40X8       | SCREW, PAN M4.37-40X8        |    |
| 44      | S08956000 | 1    | オイルフィルタ-          | OIL FILTER                   |    |
| 45      | S08957001 | 1    | オイルクチ             | OIL FEEDING PIPE             |    |
| 46      | 081044070 | 1    | OリングP44           | O RING, P44                  |    |
| 47      | S28851000 | 1    | ロカモウU             | OIL FILTER (U)               |    |
| 48      | 048240242 | 1    | トメワアナヨウC24        | RETAINING RING, C24          |    |
| 49      | S28852000 | 1    | ロカモウD             | OIL FILTER (D)               |    |
| 50      | 048180242 | 1    | トメワアナヨウC18        | RETAINING RING, C18          |    |
| 51      | 142359001 | 1    | オイルクチ             | OIL FEEDING PIPE             |    |
| 52      | S28415000 | 1    | ビニルチューブ (L = 225) | OIL TUBE (L = 225)           |    |
| 53      | 340400001 | 1    | ユニタイバンド           | BEAD BAND                    |    |
| 54      | S28416001 | 1    | アブラヨケイタ           | OIL STOPPER PLATE            |    |

From the library of: Diamond Needle Corp

J. スプレダー関係 / Spreader mechanism / Spreizvorrichtung /  
 Mécanisme de l'étendeur / Mecanismo extendedor

B257

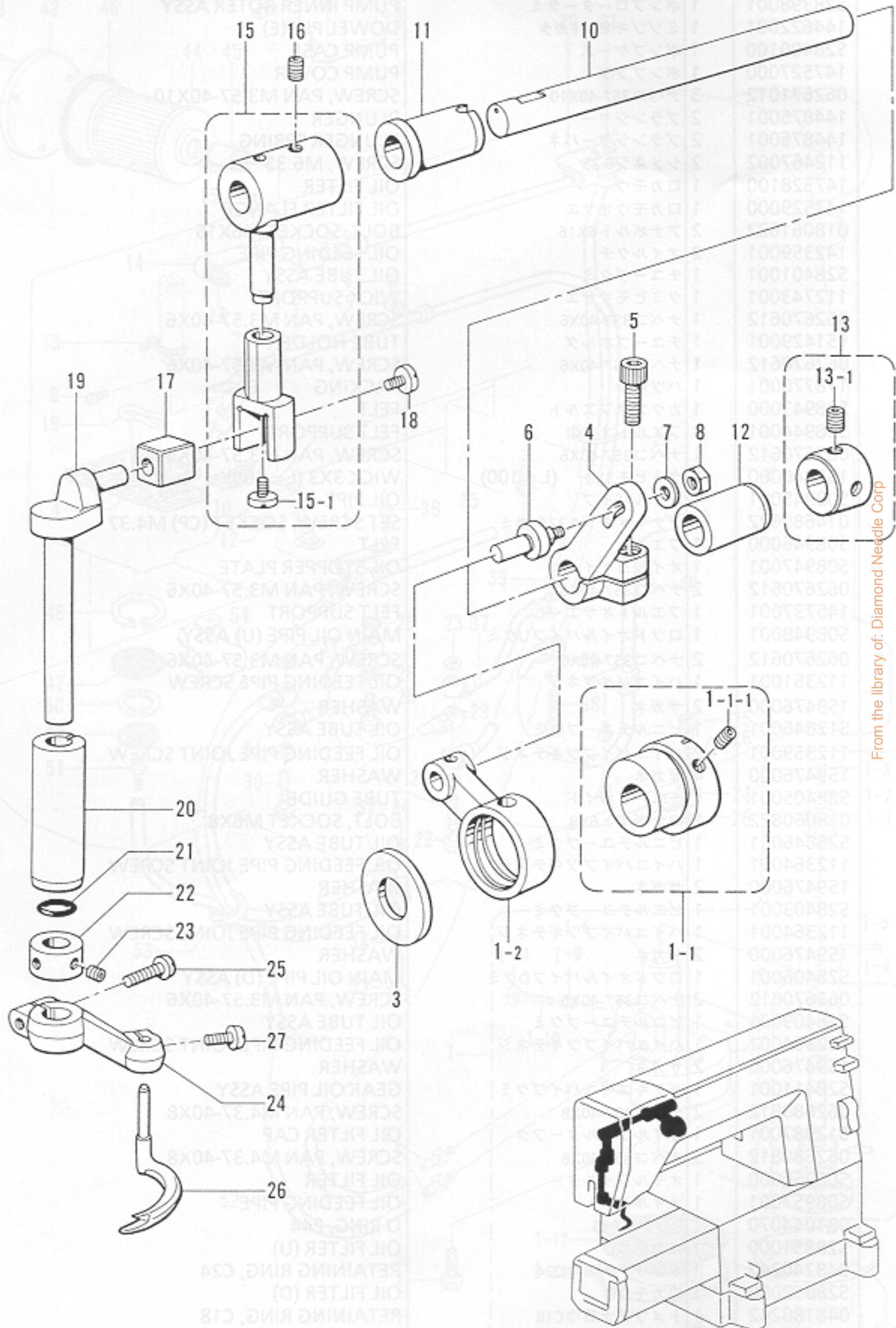

From the library of: Diamond Needle Corp

J. スプレダー関係 / Spreader mechanism / Spreizvorrichtung /  
Mécanisme de l'étendeur / Mecanismo extendedor

| REF.NO. | CODE       | Q'TY | ヒンメイ           | NAME OF PARTS                       | RM |
|---------|------------|------|----------------|-------------------------------------|----|
|         |            |      | <B257>         |                                     |    |
| 1       | S08923101  | 1    | スプレダヘンシンリンクミ   | SPREADER ECCENTRIC WHEEL ASSY       |    |
| 1-1     | S10656001  | 1    | ヘンシンリンネジツキ     | ECCENTRIC WHEEL WITH SCREW          |    |
| 1-1-1   | 014680622  | 2    | アナトメネジ4.37クボミ  | SET SCREW, SOCKET (CP) M4.37        |    |
| 1-2     | S08925000  | 1    | スプレダロッド        | SPREADER ROD                        |    |
| 3       | 101482001  | 1    | レンカンシキリイタ      | CONNECTING ROD PARTITION PLATE      |    |
| 4       | S08926101  | 1    | スプレダレバーR       | SPREADER LEVER (R)                  |    |
| 5       | 018771432  | 1    | アナボルト635-40X14 | BOLT, SOCKET M6.35-40X14            |    |
| 6       | S13809001  | 1    | スプレダロッドピン      | PIN                                 |    |
| 7       | 148847001  | 1    | ザガネ            | WASHER                              |    |
| 8       | 110161006  | 1    | ナット4.76        | NUT, M4.76                          |    |
| 10      | S08927001  | 1    | スプレダジク         | SPREADER SHAFT                      |    |
| 11      | 148196000  | 1    | ウワメスサドウウデメタルL  | SPREADER SHAFT BUSH (L)             |    |
| 12      | 148197000  | 1    | ウワメスサドウウデメタルR  | SPREADER SHAFT BUSH (R)             |    |
| 13      | S03421001  | 1    | セットカラークミ       | SET COLLAR ASSY                     |    |
| 13-1    | 014770622  | 2    | アナトメネジ6.35クボミ  | SET SCREW, SOCKET (CP) M6.35        |    |
| 15      | S08928001  | 1    | スプレダレバーLクミ     | SPREADER LEVER (L) ASSY             |    |
| 15-1    | 148834001  | 1    | シメネジ3.57       | SCREW, M3.57                        |    |
| 16      | 014770622  | 2    | アナトメネジ6.35クボミ  | SET SCREW, SOCKET (CP) M6.35        |    |
| 17      | 146547000  | 1    | オクリダイカクゴマ      | FEED BAR SLIDE BLOCK                |    |
| 18      | 148834001  | 1    | シメネジ3.57       | SCREW, M3.57                        |    |
| 19      | S08931001  | 1    | スプレダタテジク       | SPREADER VERTICAL SHAFT             |    |
| 20      | S08932000  | 1    | スプレダタテジクメタル    | SPREADER VERTICAL SHAFT BUSH        |    |
| 21      | 081007670  | 1    | リングPW7         | O RING, PW7                         |    |
| 22      | 110197001  | 1    | セットカラー         | SET COLLAR                          |    |
| 23      | 014680422  | 2    | アナトメネジ4.37クボミ  | SET SCREW, SOCKET (CP) M4.37        |    |
| 24      | S08933001  | 1    | スプレダホルダ        | SPREADER HOLDER                     |    |
| 25      | 062681412  | 1    | ナベコ437-40X14   | SCREW, PAN M4.37-40X14              |    |
| 26      | S28591001  | 1    | スプレダ           | SPREADER                            |    |
| 27      | 062681012  | 1    | ナベコ437-40X10   | SCREW, PAN M4.37-40X10              |    |
| 45-1-1  | 014770622  | 2    | アナトメネジ6.35クボミ  | SET SCREW, SOCKET (CP) M6.35        |    |
| 45-2    | S08923101  | 1    | スプレダヘンシンリンクミ   | SPREADER ECCENTRIC WHEEL WITH SCREW |    |
| 45-2-1  | 018401432  | 1    | アナボルト4X14      | BOLT, SOCKET M4X14                  |    |
| 47      | 018771432  | 1    | アナボルト635-40X14 | BOLT, SOCKET M6.35-40X14            |    |
| 48      | S089270000 | 1    | スプレダロッド        | SPREADER ROD                        |    |
| 49      | S089270000 | 1    | スプレダロッド        | SPREADER ROD                        |    |
| 50      | S089270000 | 1    | スプレダロッド        | SPREADER ROD                        |    |
| 51      | S00358001  | 1    | ザガネ            | WASHER                              |    |
| 52      | S00358001  | 1    | ザガネ            | WASHER                              |    |
| 53      | 100539000  | 1    | オストシール         | SEAL                                |    |
| 54      | S08927000  | 1    | スプレダロッド        | SPREADER ROD                        |    |
| 55      | 018771432  | 1    | アナボルト635-40X14 | BOLT, SOCKET M6.35-40X14            |    |
| 56      | 1005162000 | 1    | スプレダ           | SPREADER                            |    |
| 57      | S08927000  | 1    | スプレダロッド        | SPREADER ROD                        |    |
| 58      | 062681012  | 1    | ナベコ437-40X10   | SCREW, PAN M4.37-40X10              |    |
| 59      | 100539000  | 1    | オストシール         | SEAL                                |    |
| 68      | 062681012  | 1    | ナベコ437-40X10   | SCREW, PAN M4.37-40X10              |    |
| 69      | 062681012  | 1    | ナベコ437-40X10   | SCREW, PAN M4.37-40X10              |    |
| 70      | S08927000  | 1    | スプレダロッド        | SPREADER ROD                        |    |
| 71      | 014680622  | 1    | アナトメネジ4.37クボミ  | SET SCREW, SOCKET (CP) M4.37        |    |
| 72      | S08928001  | 1    | スプレダレバーLクミ     | SPREADER LEVER (L) ASSY             |    |
| 74      | 062681012  | 1    | ナベコ437-40X10   | SCREW, PAN M4.37-40X10              |    |
| 78      | S28591001  | 1    | スプレダ           | SPREADER                            |    |
| 81      | S08927000  | 1    | スプレダロッド        | SPREADER ROD                        |    |
| 92      | 062680612  | 1    | ナベコ437-40X10   | SCREW, PAN M4.37-40X10              |    |
| 99      | S28417001  | 1    | ヘリカスギヤクミ       | HELICAL GEAR ASSY                   |    |
| 100     | 014770622  | 4    | アナトメネジ6.35クボミ  | SET SCREW, SOCKET (CP) M6.35        |    |
| 01      | S28420001  | 1    | ピン             | TAKE-UP SHAFT                       |    |

From the library of: Diamond Needle Corp

B256

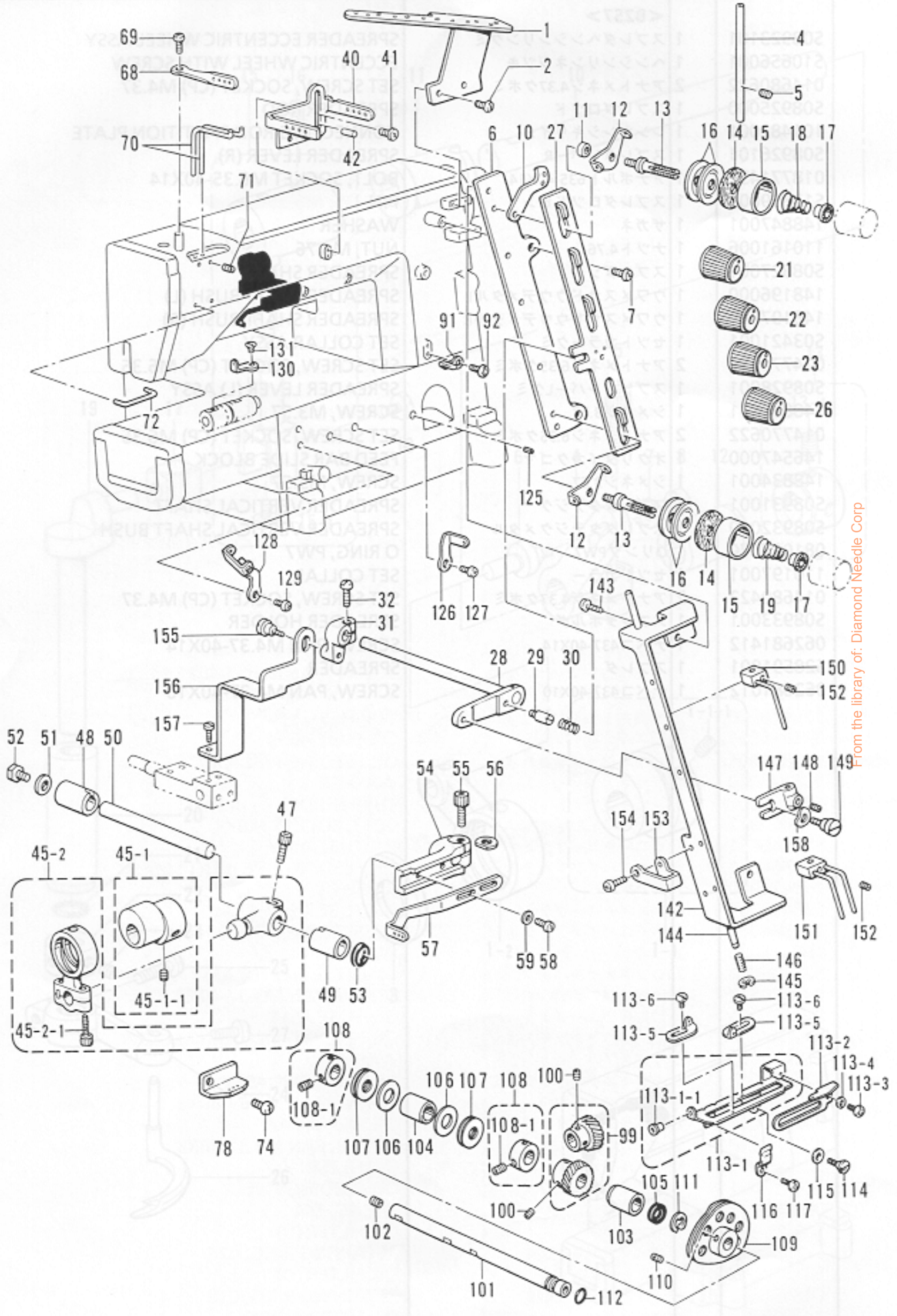

From the library of: Diamond Needle Corp

K1. 糸調子関係 / Thread tension / Faderspannung / Tension du fil / Tensión del hilo

| REF.NO. | CODE      | Q'TY | ヒンメイ             | NAME OF PARTS                        | RM |
|---------|-----------|------|------------------|--------------------------------------|----|
|         |           |      | <B256>           |                                      |    |
| 1       | S08961101 | 1    | シユイトアンナイ         | MAIN THREAD GUIDE                    |    |
| 2       | 062680812 | 2    | ナベコ437-40X8      | SCREW, PAN M4.37-40X8                |    |
| 4       | 150645009 | 1    | イトアンナイパイプL       | THREAD GUIDE PIPE (L)                |    |
| 5       | 014680422 | 1    | アナトメネジ4.37クボミ    | SET SCREW, SOCKET (CP) M4.37         |    |
| 6       | S08962109 | 1    | イトチヨウシダイ         | TENSION BASE                         |    |
| 7       | 062681012 | 2    | ナベコ437-40X10     | SCREW, PAN M4.37-40X10               |    |
| 10      | S08963001 | 4    | イトチヨウシダイイトアンナイ   | TENSION BASE THREAD GUIDE            |    |
| 11      | S21878001 | 4    | カンザ              | SPACER                               |    |
| 12      | 110813001 | 4    | ハリイトアンナイ         | NEEDLE THREAD GUIDE                  |    |
| 13      | 159574101 | 4    | イトチヨウシボウ         | TENSION STUD                         |    |
| 14      | 110832009 | 4    | イトチヨウシサラフェルト     | TENSION DISC FELT                    |    |
| 15      | 144103009 | 4    | イトチヨウシサラオサエ      | TENSION DISC PRESSER                 |    |
| 16      | 145446001 | 8    | イトチヨウシサラ         | TENSION DISC                         |    |
| 17      | S30564000 | 4    | チヨウシバネウエザガネ      | TENSION SPRING WASHER                |    |
| 18      | 144104001 | 3    | ハリイトチヨウシバネ       | THREAD TENSION ADJUST SPRING         |    |
| 19      | 144110001 | 1    | シタルーバイトチヨウシバネ    | THREAD TENSION ADJUST SPRING         |    |
| 21      | S30565003 | 1    | イトチヨウシナツト (アカ)   | TENSION NUT (RED)                    |    |
| 22      | S30565004 | 1    | イトチヨウシナツト (キイ)   | TENSION NUT (YELLOW)                 |    |
| 23      | S30565002 | 1    | イトチヨウシナツト (ミドリ)  | TENSION NUT (GREEN)                  |    |
| 26      | S30565001 | 1    | イトチヨウシナツト (ミズイロ) | TENSION NUT (LIGHT BLUE)             |    |
| 27      | S21879001 | 1    | イトユルメイタ          | TENSION RELEASE PLATE                |    |
| 28      | S21880001 | 1    | イトユルメジク          | TENSION RELEASE SHAFT                |    |
| 29      | S21881001 | 1    | シメネジ4.76         | SCREW, M4.76                         |    |
| 30      | S21882001 | 1    | イトユルメイタオシバネ      | SPRING                               |    |
| 31      | S21883001 | 1    | イトユルメウデ          | TENSION RELEASE ARM                  |    |
| 32      | 062681212 | 1    | ナベコ437-40X12     | SCREW, PAN M4.37-40X12               |    |
| 40      | S08969101 | 1    | チユウカンイトアンナイ      | THREAD GUIDE                         |    |
| 41      | 060680712 | 1    | バインド437-40X7     | SCREW, BIND M4.37-40X7               |    |
| 42      | 143602001 | 1    | ミゾツキピン           | DOWEL PIN                            |    |
| 45      | S08971201 | 1    | ハリイトクリヘンシンリンクミ   | NEEDLE THREAD TAKE-UP ECCENTRIC ASSY |    |
| 45-1    | S10657001 | 1    | イトクリヘンシンリンネジツキ   | TAKE-UP ECCENTRIC WHEEL WITH SCREW   |    |
| 45-1-1  | 014770622 | 2    | アナトメネジ6.35クボミ    | SET SCREW, SOCKET (CP) M6.35         |    |
| 45-2    | S08973101 | 1    | ハリイトクリロツドクミ      | THREAD TAKE-UP ECCENTRIC ROD ASSY    |    |
| 45-2-1  | 018401422 | 2    | アナボルト4X14        | BOLT, SOCKET M4X14                   |    |
| 47      | 018771432 | 1    | アナボルト635-40X14   | BOLT, SOCKET M6.35-40X14             |    |
| 48      | 155220000 | 1    | ホジヨアツメタルR        | AUTO PRESSER ARM BUSH (R)            |    |
| 49      | S08770000 | 1    | ジクメタル            | SHAFT BUSH                           |    |
| 50      | S08976001 | 1    | ハリイトクリジク         | NEEDLE THREAD TAKE-UP SHAFT          |    |
| 51      | S00356001 | 1    | ザガネ              | WASHER                               |    |
| 52      | S00383001 | 1    | ボルト5.56X8        | BOLT, M5.56X8                        |    |
| 53      | 155539000 | 1    | ダストシール           | DUST SEAL                            |    |
| 54      | S08977001 | 1    | ハリイトクリレバー        | NEEDLE THREAD TAKE-UP LEVER          |    |
| 55      | 018771432 | 1    | アナボルト635-40X14   | BOLT, SOCKET M6.35-40X14             |    |
| 56      | 155162001 | 1    | スペーサ             | SPACER                               |    |
| 57      | S08978001 | 1    | ハリイトクリ           | NEEDLE THREAD TAKE-UP                |    |
| 58      | 062681012 | 2    | ナベコ437-40X10     | SCREW, PAN M4.37-40X10               |    |
| 59      | 100645003 | 2    | ザガネ              | WASHER                               |    |
| 68      | S08981001 | 1    | ハリボウテンピン         | NEEDLE BAR TAKE-UP                   |    |
| 69      | 062670612 | 1    | ナベコ357-40X6      | SCREW, PAN M3.57-40X6                |    |
| 70      | S08982001 | 2    | ハリイトウケ           | NEEDLE THREAD GUIDE                  |    |
| 71      | 014680422 | 2    | アナトメネジ4.37クボミ    | SET SCREW, SOCKET (CP) M4.37         |    |
| 72      | S08983001 | 1    | アームハリイトウケ        | ARM NEEDLE THREAD GUIDE              |    |
| 74      | 062680812 | 1    | ナベコ437-40X8      | SCREW, PAN M4.37-40X8                |    |
| 78      | S28438001 | 1    | アームイトアンナイD       | ARM THREAD GUIDE (D)                 |    |
| 91      | S08970001 | 1    | イトアンナイS          | THREAD GUIDE (S)                     |    |
| 92      | 062680612 | 1    | ナベコ4.37-40X6     | SCREW, PAN M4.37-40X6                |    |
| 99      | S28417001 | 1    | ヘリカルギヤクミ         | HELICAL GEAR ASSY                    |    |
| 100     | 014770622 | 4    | アナトメネジ6.35クボミ    | SET SCREW, SOCKET (CP) M6.35         |    |
| 101     | S28420001 | 1    | テンピンジク           | TAKE-UP SHAFT                        |    |

From the library of: Diamond Needle Corp

B256

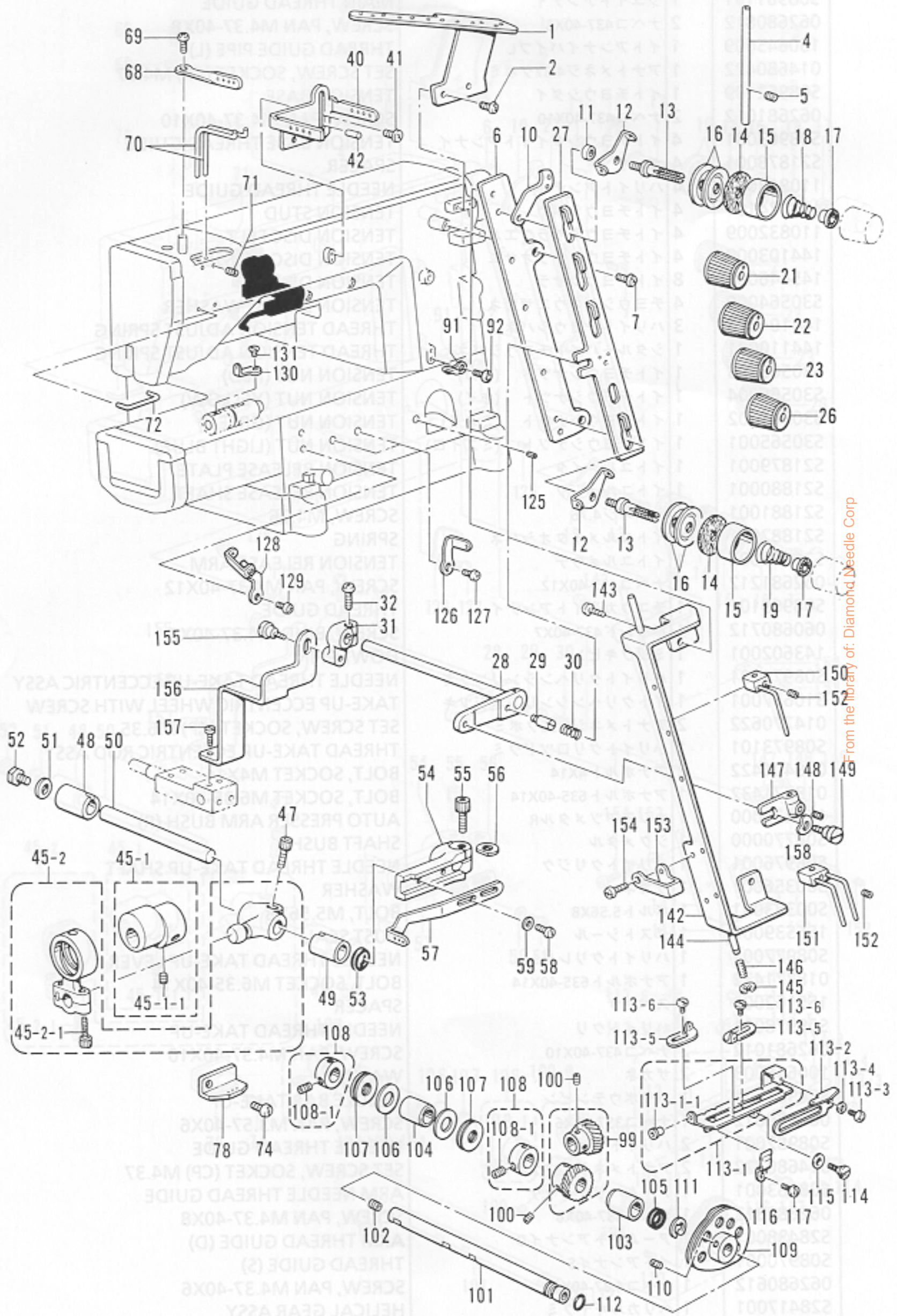

From the library of: Diamond Needle Corp

K1. 糸調子関係 / Thread tension / Faderspannung / Tension du fil / Tensión del hilo

| REF.NO. | CODE      | Q'TY | ヒンメイ          | NAME OF PARTS                   | RM |
|---------|-----------|------|---------------|---------------------------------|----|
| 102     | 014770622 | 1    | アナトメネジ6.35クボミ | SET SCREW, SOCKET (CP) M6.35    |    |
| 103     | S28421000 | 1    | テンビンジクメタルF    | TAKE-UP SHAFT BUSH (F)          |    |
| 104     | S28422000 | 1    | テンビンジクメタルB    | TAKE-UP SHAFT BUSH (B)          |    |
| 105     | S28423000 | 1    | ダストシール        | DUST SEAL                       |    |
| 106     | S28424001 | 2    | スラストザガネ       | THRUST WASHER                   |    |
| 107     | S08238000 | 2    | スラストベアリング     | THRUST BEARING                  |    |
| 108     | S28425001 | 2    | セットカラークミ      | SET COLLAR ASSY                 |    |
| 108-1   | 014770622 | 4    | アナトメネジ6.35クボミ | SET SCREW, SOCKET (CP) M6.35    |    |
| 109     | S28427001 | 1    | シタイトテンビクミ     | LOOPER THREAD TAKE-UP ASSY      |    |
| 110     | 014680422 | 2    | アナトメネジ4.37クボミ | SET SCREW, SOCKET (CP) M4.37    |    |
| 111     | 048090342 | 1    | トメワE9         | RETAINING RING, E9              |    |
| 112     | 081008070 | 1    | OリングP8        | O RING, P8                      |    |
| 113     | S28796001 | 1    | テンビンドダイソウクミ   | LOOPER THREAD TAKE-UP BASE SET  |    |
| 113-1   | S28431001 | 1    | テンビンドダイクミ     | LOOPER THREAD TAKE-UP BASE ASSY |    |
| 113-1-1 | 146924000 | 1    | スレッドブツシュ      | THREAD BUSH                     |    |
| 113-2   | S28434001 | 1    | テンビンイトサバキ     | THREAD HANDLER                  |    |
| 113-3   | 062670612 | 1    | ナベコ357-40X6   | SCREW, PAN M3.57-40X6           |    |
| 113-4   | 105161004 | 1    | ザガネ           | WASHER                          |    |
| 113-5   | S28435001 | 2    | テンビンイトアンナイ    | TAKE-UP THREAD GUIDE            |    |
| 113-6   | 105288001 | 2    | シメネジ2.38      | SCREW, M2.38                    |    |
| 114     | S08777001 | 1    | ダンネジ4.37      | STUD SCREW, M4.37               |    |
| 115     | 103810002 | 1    | ナミガタバネザガネ     | WAVE SPRING WASHER              |    |
| 116     | 155318001 | 1    | ドダイオサエバネ      | SPRING                          |    |
| 117     | 062670612 | 1    | ナベコ357-40X6   | SCREW, PAN M3.57-40X6           |    |
| 125     | 047200642 | 1    | スプリングピンAW2    | PIN, SPRING ROLL AW2            |    |
| 126     | S08970001 | 2    | イトアンナイS       | THREAD GUIDE (S)                |    |
| 127     | 062680612 | 2    | ナベコ4.37-40X6  | SCREW, PAN M4.37-40X6           |    |
| 128     | S28436001 | 1    | シタイトアンナイF     | LOOPER THREAD GUIDE (F)         |    |
| 129     | 062680612 | 1    | ナベコ4.37-40X6  | SCREW, PAN M4.37-40X6           |    |
| 130     | S28437001 | 1    | シタイトアンナイB     | LOOPER THREAD GUIDE (B)         |    |
| 131     | 149288003 | 1    | サラネジ3.18      | SCREW, FLAT M3.18               |    |
| 142     | S21884001 | 1    | イトユルメアンナイ     | TENSION RELEASE GUIDE           |    |
| 143     | 060680512 | 2    | バインド437-40X5  | SCREW, BIND M4.37-40X5          |    |
| 144     | S21885001 | 1    | イトトリジク        | THREAD TAKE-UP SHAFT            |    |
| 145     | 048030342 | 1    | トメワE3         | RETAINING RING, E3              |    |
| 146     | S21886001 | 1    | カンシヨウバネ       | SHOCK ABSORBING SPRING          |    |
| 147     | S21887001 | 1    | イトトリレバー       | THREAD TAKE-UP LEVER            |    |
| 148     | 014680422 | 1    | アナトメネジ4.37クボミ | SET SCREW, SOCKET (CP) M4.37    |    |
| 149     | 144526001 | 1    | ダンネジ4.37      | STUD SCREW, M4.37               |    |
| 150     | S21888001 | 3    | イトトリブロックSクミ   | THREAD TAKE-UP BLOCK (S) ASSY   |    |
| 151     | S21891001 | 1    | イトトリブロックWクミ   | THREAD TAKE-UP BLOCK (W) ASSY   |    |
| 152     | 014680422 | 4    | アナトメネジ4.37クボミ | SET SCREW, SOCKET (CP) M4.37    |    |
| 153     | S21893001 | 1    | イトユルメイトミチ     | THREAD HANDLING AREA            |    |
| 154     | 062670512 | 1    | ナベコ357-40X5   | SCREW, PAN M3.57-40X5           |    |
| 155     | 144526001 | 1    | ダンネジ4.37      | STUD SCREW, M4.37               |    |
| 156     | S21894001 | 1    | イトユルメクドウイタ    | TENSION RELEASE DRIVING PLATE   |    |
| 157     | 100644005 | 2    | シメネジ4.37      | SCREW, M4.37                    |    |
| 158     | 103810002 | 1    | ナミガタバネザガネ     | WAVE SPRING WASHER              |    |

From the library of: Diamond Needle Corp



B257

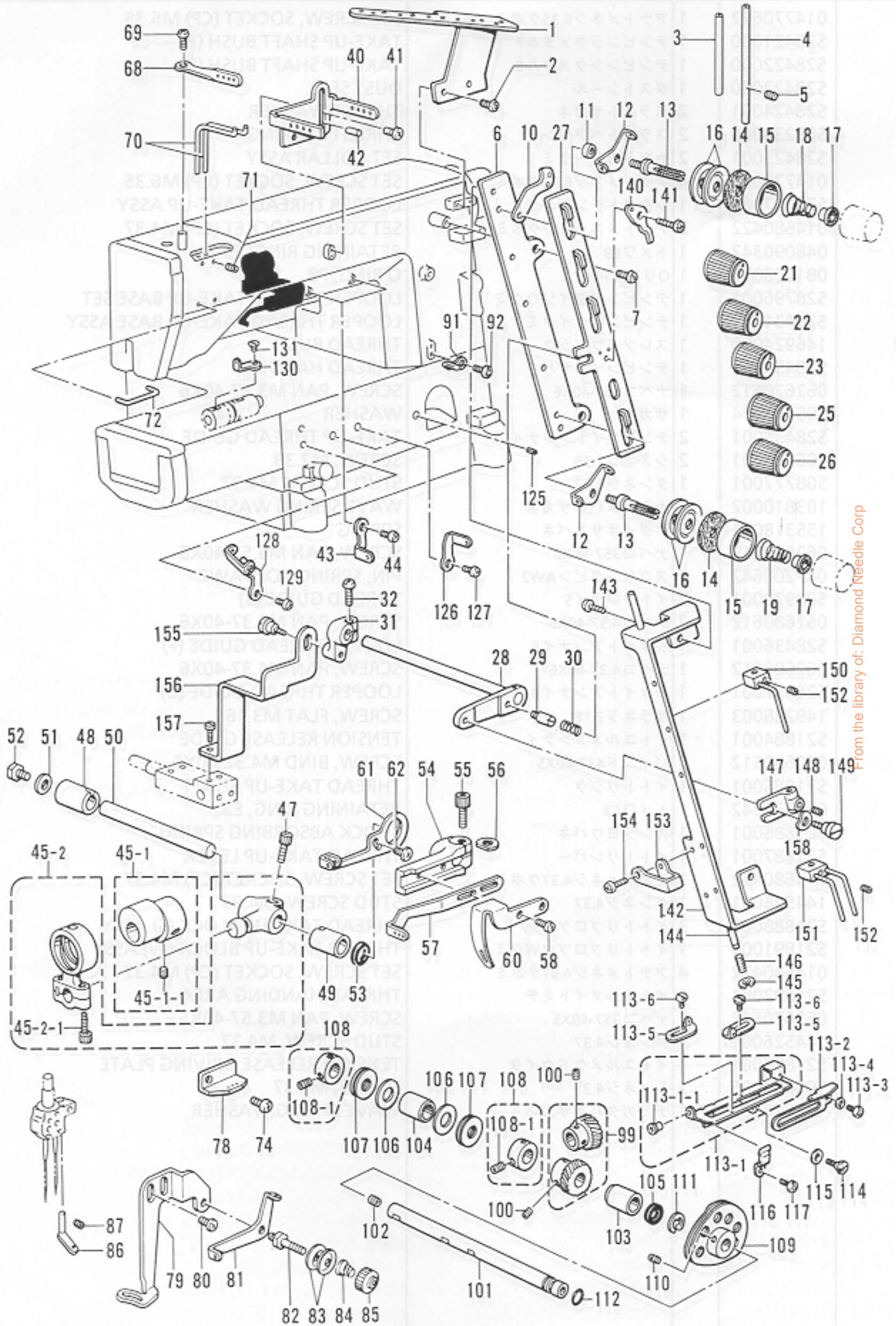

From the library of: Diamond Needle Corp

K2. 糸調子関係 / Thread tension / Faderspannung / Tension du fil / Tensión del hilo

| REF.NO. | CODE      | Q'TY | ヒンメイ             | NAME OF PARTS                        | RM |
|---------|-----------|------|------------------|--------------------------------------|----|
|         |           |      | <B257>           | SCREW BIND M4.37-40X7                |    |
| 1       | S08961101 | 1    | シユイトアンナイ         | MAIN THREAD GUIDE                    |    |
| 2       | 062680812 | 2    | ナベコ437-40X8      | SCREW, PAN M4.37-40X8                |    |
| 3       | 150644009 | 1    | イトアンナイパイプS       | THREAD GUIDE PIPE (S)                |    |
| 4       | 150645009 | 1    | イトアンナイパイプL       | THREAD GUIDE PIPE (L)                |    |
| 5       | 014680422 | 2    | アナトメネジ4.37クボミ    | SET SCREW, SOCKET (CP) M4.37         |    |
| 6       | S08962109 | 1    | イトチヨウシダイ         | TENSION BASE                         |    |
| 7       | 062681012 | 2    | ナベコ437-40X10     | SCREW, PAN M4.37-40X10               |    |
| 10      | S08963001 | 5    | イトチヨウシダイイトアンナイ   | TENSION BASE THREAD GUIDE            |    |
| 11      | S21878001 | 5    | カンザ              | SPACER                               |    |
| 12      | 110813001 | 5    | ハライトアンナイ         | NEEDLE THREAD GUIDE                  |    |
| 13      | 159574101 | 5    | イトチヨウシボウ         | TENSION STUD                         |    |
| 14      | 110832009 | 5    | イトチヨウシサラフェルト     | TENSION DISC FELT                    |    |
| 15      | 144103009 | 5    | イトチヨウシサラオサエ      | TENSION DISC PRESSER                 |    |
| 16      | 145446001 | 10   | イトチヨウシサラ         | TENSION DISC                         |    |
| 17      | S30564000 | 5    | チヨウシバネウエザガネ      | TENSION SPRING WASHER                |    |
| 18      | 144104001 | 3    | ハライトチヨウシバネ       | THREAD TENSION ADJUST SPRING         |    |
| 19      | 144110001 | 2    | シタルーバイトチヨウシバネ    | THREAD TENSION ADJUST SPRING         |    |
| 21      | S30565003 | 1    | イトチヨウシナツト (アカ)   | TENSION NUT (RED)                    |    |
| 22      | S30565004 | 1    | イトチヨウシナツト (キイ)   | TENSION NUT (YELLOW)                 |    |
| 23      | S30565002 | 1    | イトチヨウシナツト (ミドリ)  | TENSION NUT (GREEN)                  |    |
| 25      | S30565003 | 1    | イトチヨウシナツト (アカ)   | TENSION NUT (RED)                    |    |
| 26      | S30565001 | 1    | イトチヨウシナツト (ミズイロ) | TENSION NUT (LIGHT BLUE)             |    |
| 27      | S21879001 | 1    | イトユルメイタ          | TENSION RELEASE PLATE                |    |
| 28      | S21880001 | 1    | イトユルメジク          | TENSION RELEASE SHAFT                |    |
| 29      | S21881001 | 1    | シメネジ4.76         | SCREW, M4.76                         |    |
| 30      | S21882001 | 1    | イトユルメイタオシバネ      | SPRING                               |    |
| 31      | S21883001 | 1    | イトユルメウデ          | TENSION RELEASE ARM                  |    |
| 32      | 062681212 | 1    | ナベコ437-40X12     | SCREW, PAN M4.37-40X12               |    |
| 40      | S08969101 | 1    | チユウカンイトアンナイ      | THREAD GUIDE                         |    |
| 41      | 060680712 | 1    | バインド437-40X7     | SCREW, BIND M4.37-40X7               |    |
| 42      | 143602001 | 1    | ミゾツキピン           | DOWEL PIN                            |    |
| 43      | S08970001 | 2    | イトアンナイS          | THREAD GUIDE (S)                     |    |
| 44      | 062680612 | 2    | ナベコ4.37-40X6     | SCREW, PAN M4.37-40X6                |    |
| 45      | S08971201 | 1    | ハライトクリヘンシンリンクミ   | NEEDLE THREAD TAKE-UP ECCENTRIC ASSY |    |
| 45-1    | S10657001 | 1    | イトクリヘンシンリンネジツキ   | TAKE-UP ECCENTRIC WHEEL WITH SCREW   |    |
| 45-1-1  | 014770622 | 2    | アナトメネジ6.35クボミ    | SET SCREW, SOCKET (CP) M6.35         |    |
| 45-2    | S08973101 | 1    | ハライトクリロツドクミ      | THREAD TAKE-UP ECCENTRIC ROD ASSY    |    |
| 45-2-1  | 018401422 | 2    | アナボルト4X14        | BOLT, SOCKET M4X14                   |    |
| 47      | 018771432 | 1    | アナボルト635-40X14   | BOLT, SOCKET M6.35-40X14             |    |
| 48      | 155220000 | 1    | ホジヨアツメタルR        | AUTO PRESSER ARM BUSH (R)            |    |
| 49      | S08770000 | 1    | ジクメタル            | SHAFT BUSH                           |    |
| 50      | S08976001 | 1    | ハライトクリジク         | NEEDLE THREAD TAKE-UP SHAFT          |    |
| 51      | S00356001 | 1    | ザガネ              | WASHER                               |    |
| 52      | S00383001 | 1    | ボルト5.56X8        | BOLT, M5.56X8                        |    |
| 53      | 155539000 | 1    | ダストシール           | DUST SEAL                            |    |
| 54      | S08977001 | 1    | ハライトクリレバー        | NEEDLE THREAD TAKE-UP LEVER          |    |
| 55      | 018771432 | 1    | アナボルト635-40X14   | BOLT, SOCKET M6.35-40X14             |    |
| 56      | 155162001 | 1    | スパーサ             | SPACER                               |    |
| 57      | S08978001 | 1    | ハライトクリ           | NEEDLE THREAD TAKE-UP                |    |
| 58      | 062681012 | 2    | ナベコ437-40X10     | SCREW, PAN M4.37-40X10               |    |
| 60      | S08979001 | 1    | カザリイトクリ          | COVERING THREAD TAKE-UP              |    |
| 61      | S08980001 | 1    | カザリイトアンナイR       | COVERING THREAD GUIDE (R)            |    |
| 62      | 060680712 | 1    | バインド437-40X7     | SCREW, BIND M4.37-40X7               |    |
| 68      | S08981001 | 1    | ハリボウテンピン         | NEEDLE BAR TAKE-UP                   |    |
| 69      | 062670612 | 1    | ナベコ357-40X6      | SCREW, PAN M3.57-40X6                |    |
| 70      | S08982001 | 2    | ハライトウケ           | NEEDLE THREAD GUIDE                  |    |
| 71      | 014680422 | 2    | アナトメネジ4.37クボミ    | SET SCREW, SOCKET (CP) M4.37         |    |
| 72      | S08983001 | 1    | アームハライトウケ        | ARM NEEDLE THREAD GUIDE              |    |
| 74      | 062680812 | 1    | ナベコ437-40X8      | SCREW, PAN M4.37-40X8                |    |
| 78      | S28438001 | 1    | アームイトアンナイD       | ARM THREAD GUIDE (D)                 |    |
| 79      | S08985001 | 1    | カザリイトアンナイL       | COVERING THREAD GUIDE (L)            |    |



K2. 糸調子関係 / Thread tension / Faderspannung / Tension du fil / Tensión del hilo

| REF.NO. | CODE      | Q'TY | ヒンメイ          | NAME OF PARTS                   | RM |
|---------|-----------|------|---------------|---------------------------------|----|
| 80      | 060680712 | 2    | バインド437-40X7  | SCREW, BIND M4.37-40X7          |    |
| 81      | S08986001 | 1    | カザライトアンナイ     | COVERING THREAD GUIDE           |    |
| 82      | S08987001 | 1    | イトチヨウシボウ      | THREAD TENSION CONTROL STUD     |    |
| 83      | 144504001 | 2    | イトアンナイサラ      | THREAD GUIDE DISC               |    |
| 84      | 144505000 | 1    | イトアンナイバネ      | SPRING                          |    |
| 85      | 155510001 | 1    | イトチヨウシナツト     | TENSION NUT                     |    |
| 86      | S08988001 | 1    | ハリドメカザライトアンナイ | NEEDLE CLAMP THREAD GUIDE       |    |
| 87      | 146427001 | 1    | アナトメネジ3.18クボミ | SET SCREW, SOCKET (CP) M3.18    |    |
| 91      | S08970001 | 1    | イトアンナイS       | THREAD GUIDE (S)                |    |
| 92      | 062680612 | 1    | ナベコ4.37-40X6  | SCREW, PAN M4.37-40X6           |    |
| 99      | S28417001 | 1    | ヘリカルギヤクミ      | HELICAL GEAR ASSY               |    |
| 100     | 014770622 | 4    | アナトメネジ6.35クボミ | SET SCREW, SOCKET (CP) M6.35    |    |
| 101     | S28420001 | 1    | テンビンジク        | TAKE-UP SHAFT                   |    |
| 102     | 014770622 | 1    | アナトメネジ6.35クボミ | SET SCREW, SOCKET (CP) M6.35    |    |
| 103     | S28421000 | 1    | テンビンジクメタルF    | TAKE-UP SHAFT BUSH (F)          |    |
| 104     | S28422000 | 1    | テンビンジクメタルB    | TAKE-UP SHAFT BUSH (B)          |    |
| 105     | S28423000 | 1    | ダストシール        | DUST SEAL                       |    |
| 106     | S28424001 | 2    | スラストザガネ       | THRUST WASHER                   |    |
| 107     | S08238000 | 2    | スラストベアリング     | THRUST BEARING                  |    |
| 108     | S28425001 | 2    | セツトカラークミ      | SET COLLAR ASSY                 |    |
| 108-1   | 014770622 | 4    | アナトメネジ6.35クボミ | SET SCREW, SOCKET (CP) M6.35    |    |
| 109     | S28427001 | 1    | シタイトテンビクミ     | LOOPER THREAD TAKE-UP ASSY      |    |
| 110     | 014680422 | 2    | アナトメネジ4.37クボミ | SET SCREW, SOCKET (CP) M4.37    |    |
| 111     | 048090342 | 1    | トメワE9         | RETAINING RING, E9              |    |
| 112     | 081008070 | 1    | OリングP8        | O RING, P8                      |    |
| 113     | S28796001 | 1    | テンビンドダイソウクミ   | LOOPER THREAD TAKE-UP BASE SET  |    |
| 113-1   | S28431001 | 1    | テンビンドダイクミ     | LOOPER THREAD TAKE-UP BASE ASSY |    |
| 113-1-1 | 146924000 | 1    | スレツドブツシュ      | THREAD BUSH                     |    |
| 113-2   | S28434001 | 1    | テンビンイトサバキ     | THREAD HANDLER                  |    |
| 113-3   | 062670612 | 1    | ナベコ357-40X6   | SCREW, PAN M3.57-40X6           |    |
| 113-4   | 105161004 | 1    | ザガネ           | WASHER                          |    |
| 113-5   | S28435001 | 2    | テンビンイトアンナイ    | TAKE-UP THREAD GUIDE            |    |
| 113-6   | 105288001 | 2    | シメネジ2.38      | SCREW, M2.38                    |    |
| 114     | S08777001 | 1    | ダンネジ4.37      | STUD SCREW, M4.37               |    |
| 115     | 103810002 | 1    | ナミガタバネザガネ     | WAVE SPRING WASHER              |    |
| 116     | 155318001 | 1    | ドダイオサエバネ      | SPRING                          |    |
| 117     | 062670612 | 1    | ナベコ357-40X6   | SCREW, PAN M3.57-40X6           |    |
| 125     | 047200642 | 1    | スプリングピンAW2    | PIN, SPRING ROLL AW2            |    |
| 126     | S08970001 | 2    | イトアンナイS       | THREAD GUIDE (S)                |    |
| 127     | 062680612 | 2    | ナベコ4.37-40X6  | SCREW, PAN M4.37-40X6           |    |
| 128     | S28436001 | 1    | シタイトアンナイF     | LOOPER THREAD GUIDE (F)         |    |
| 129     | 062680612 | 1    | ナベコ4.37-40X6  | SCREW, PAN M4.37-40X6           |    |
| 130     | S28437001 | 1    | シタイトアンナイB     | LOOPER THREAD GUIDE (B)         |    |
| 131     | 149288003 | 1    | サラネジ3.18      | SCREW, FLAT M3.18               |    |
| 140     | S21963001 | 1    | イトユルメイタS      | TENSION RELEASE PLATE (S)       |    |
| 141     | 060680512 | 1    | バインド437-40X5  | SCREW, BIND M4.37-40X5          |    |
| 142     | S21884001 | 1    | イトユルメアンナイ     | TENSION RELEASE GUIDE           |    |
| 143     | 060680512 | 2    | バインド437-40X5  | SCREW, BIND M4.37-40X5          |    |
| 144     | S21885001 | 1    | イトトリジク        | THREAD TAKE-UP SHAFT            |    |
| 145     | 048030342 | 1    | トメワE3         | RETAINING RING, E3              |    |
| 146     | S21886001 | 1    | カンシヨウバネ       | SHOCK ABSORBING SPRING          |    |
| 147     | S21887001 | 1    | イトトリレバー       | THREAD TAKE-UP LEVER            |    |
| 148     | 014680422 | 1    | アナトメネジ4.37クボミ | SET SCREW, SOCKET (CP) M4.37    |    |
| 149     | 144526001 | 1    | ダンネジ4.37      | STUD SCREW, M4.37               |    |
| 150     | S21888001 | 3    | イトトリブロツクSクミ   | THREAD TAKE-UP BLOCK (S) ASSY   |    |
| 151     | S21891001 | 2    | イトトリブロツクWクミ   | THREAD TAKE-UP BLOCK (W) ASSY   |    |
| 152     | 014680422 | 5    | アナトメネジ4.37クボミ | SET SCREW, SOCKET (CP) M4.37    |    |
| 153     | S21893001 | 2    | イトユルメイトミチ     | THREAD HANDLING AREA            |    |
| 154     | 062670512 | 2    | ナベコ357-40X5   | SCREW, PAN M3.57-40X5           |    |
| 155     | 144526001 | 1    | ダンネジ4.37      | STUD SCREW, M4.37               |    |
| 156     | S21894001 | 1    | イトユルメクドウイタ    | TENSION RELEASE DRIVING PLATE   |    |
| 157     | 100644005 | 2    | シメネジ4.37      | SCREW, M4.37                    |    |
| 158     | 103810002 | 1    | ナミガタバネザガネ     | WAVE SPRING WASHER              |    |

From the library of: Diamond Needle Corp

B257-0V1

三ツ折 / Clean finish top and raw edge bottom

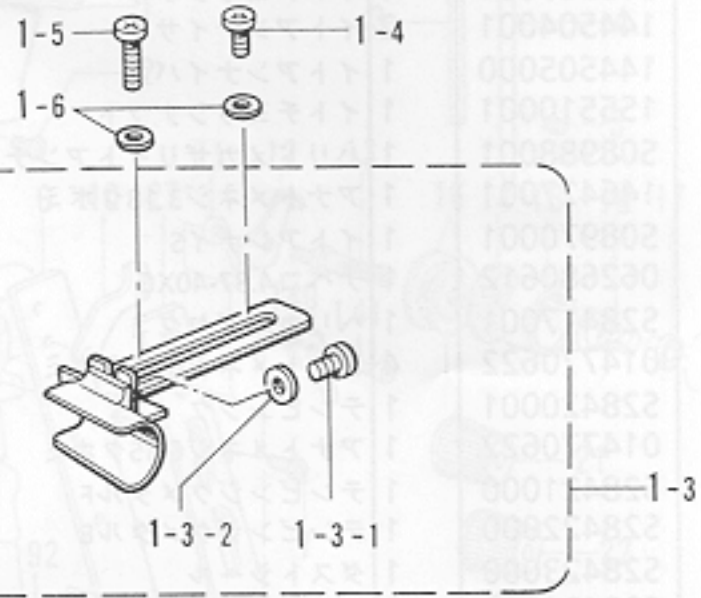
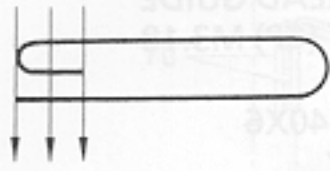

30mm

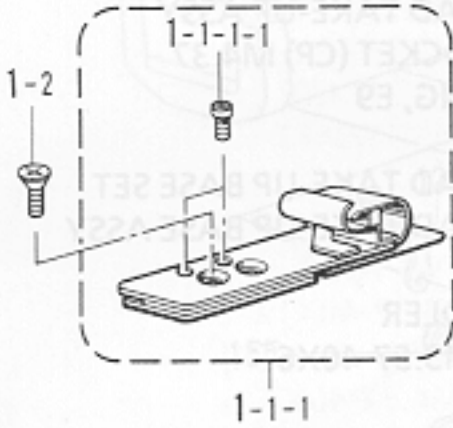

35mm  
 <標準 / STANDARD>

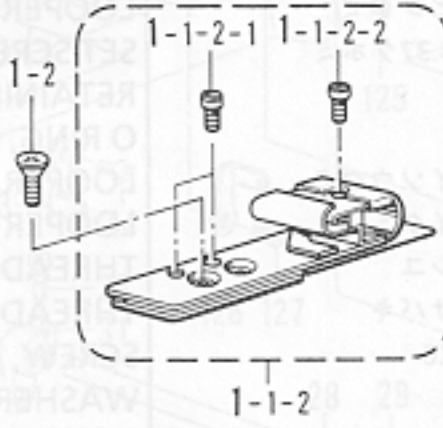

40mm

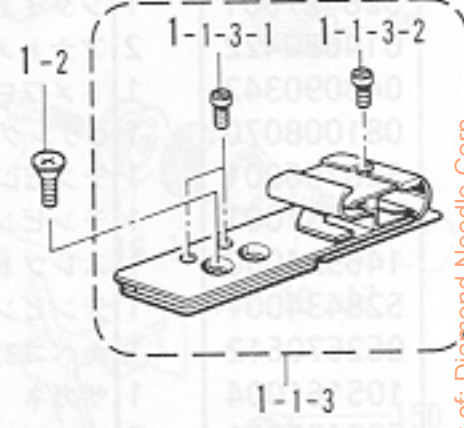

二ツ折 / Raw edge top and bottom

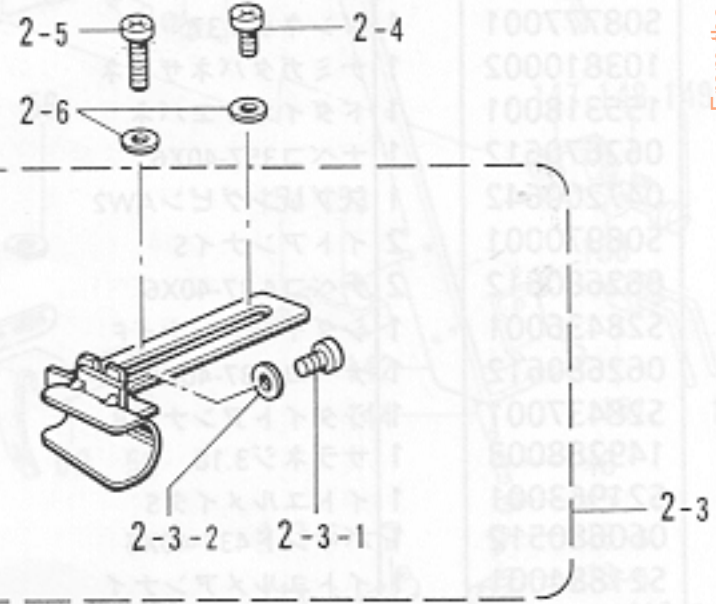
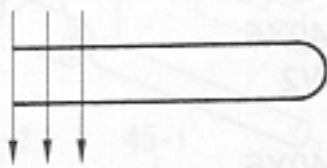

30mm

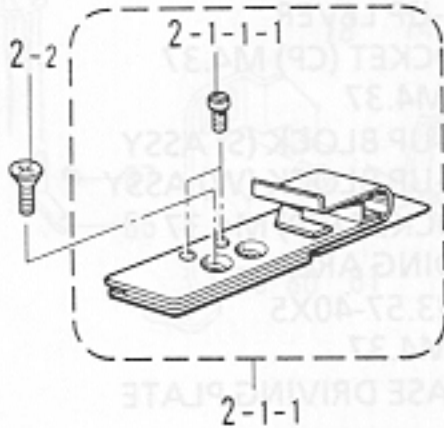

35mm

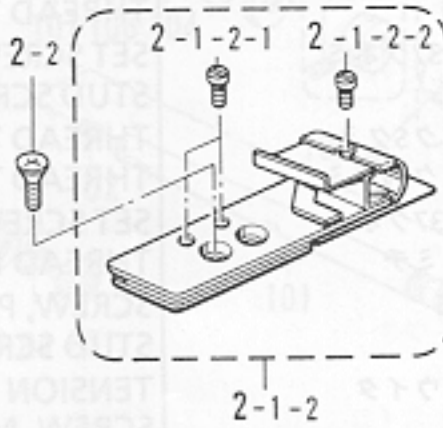

40mm

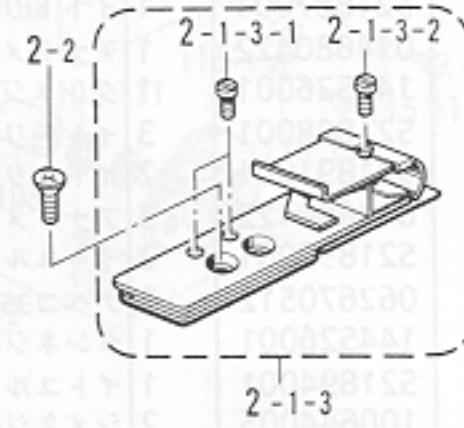

From the library of: Diamond Needle Corp

L. ラッパー関係 / Lapper mechanism / Falz-mechanismus /  
 Mécanisme à rabat / Mecanismo de solapado

| REF.NO.                                       | CODE      | Q'TY | ヒンメイ         | NAME OF PARTS          | RM |
|---|-----------|------|--------------|------------------------|----|
| <B257-0V1>                                    |           |      |              |                        |    |
| <三つ折り / CLEAN FINISH TOP AND FAW EDGE BOTTOM> |           |      |              |                        |    |
| 1-2   | 003400804 | 2    | サラネジ4X8      | SCREW, FLAT M4X8       |    |
| 1-3   | S28606001 | 1    | ゴムガイドRクミ     | RUBBER GUIDE (R) ASSY  |    |
| 1-3-1   | 062670412 | 1    | ナベコ357-40X4  | SCREW, PAN M3.57-40X4  |    |
| 1-3-2   | 105161004 | 1    | ザガネ          | WASHER                 |    |
| 1-4   | 062710612 | 1    | ナベコ476-32X6  | SCREW, PAN M4.76-32X6  |    |
| 1-5   | 062711212 | 1    | ナベコ476-32X12 | SCREW, PAN M4.76-32X12 |    |
| 1-6   | 148847001 | 2    | ザガネ          | WASHER                 |    |
| <30MM>  |           |      |              |                        |    |
| 1   | S28601001 | 1    | ゴムバインダークミ    | RUBBER BINDER ASSY     |    |
| 1-1-1   | S28602001 | 1    | ゴムガイドLクミ     | RUBBER GUIDE (L) ASSY  |    |
| 1-1-1-1                                       | 141544001 | 2    | シメネジ3.18     | SCREW, M3.18           |    |
| <35MM> <標準 / STANDARD>                        |           |      |              |                        |    |
| 1   | S28609001 | 1    | ゴムバインダークミ    | RUBBER BINDER ASSY     |    |
| 1-1-2   | S28610001 | 1    | ゴムガイドLクミ     | RUBBER GUIDE (L) ASSY  |    |
| 1-1-2-1                                       | 141544001 | 2    | シメネジ3.18     | SCREW, M3.18           |    |
| 1-1-2-2                                       | 110215002 | 1    | シメネジ3.57     | SCREW, M3.57           |    |
| <40MM>  |           |      |              |                        |    |
| 1   | S28614001 | 1    | ゴムバインダークミ    | RUBBER BINDER ASSY     |    |
| 1-1-3   | S28615001 | 1    | ゴムガイドLクミ     | RUBBER GUIDE (L) ASSY  |    |
| 1-1-3-1                                       | 141544001 | 2    | シメネジ3.18     | SCREW, M3.18           |    |
| 1-1-3-2                                       | 110215002 | 1    | シメネジ3.57     | SCREW, M3.57           |    |
| <二つ折り / RAW EDGE TOP AND BOTTOM>              |           |      |              |                        |    |
| 2-2   | 003400804 | 2    | サラネジ4X8      | SCREW, FLAT M4X8       |    |
| 2-3   | S28604001 | 1    | ゴムガイドRクミ     | RUBBER GUIDE (R) ASSY  |    |
| 2-3-1   | 062670412 | 1    | ナベコ357-40X4  | SCREW, PAN M3.57-40X4  |    |
| 2-3-2   | 105161004 | 1    | ザガネ          | WASHER                 |    |
| 2-4   | 062710612 | 1    | ナベコ476-32X6  | SCREW, PAN M4.76-32X6  |    |
| 2-5   | 062711212 | 1    | ナベコ476-32X12 | SCREW, PAN M4.76-32X12 |    |
| 2-6   | 148847001 | 2    | ザガネ          | WASHER                 |    |
| <30MM>  |           |      |              |                        |    |
| 2   | S28619001 | 1    | ゴムバインダークミ    | RUBBER BINDER ASSY     |    |
| 2-1-1   | S28620001 | 1    | ゴムガイドLクミ     | RUBBER GUIDE (L) ASSY  |    |
| 2-1-1-1                                       | 141544001 | 2    | シメネジ3.18     | SCREW, M3.18           |    |
| <35MM>  |           |      |              |                        |    |
| 2   | S28622001 | 1    | ゴムバインダークミ    | RUBBER BINDER ASSY     |    |
| 2-1-2   | S28623001 | 1    | ゴムガイドLクミ     | RUBBER GUIDE (L) ASSY  |    |
| 2-1-2-1                                       | 141544001 | 2    | シメネジ3.18     | SCREW, M3.18           |    |
| 2-1-2-2                                       | 110215002 | 1    | シメネジ3.57     | SCREW, M3.57           |    |
| <40MM>  |           |      |              |                        |    |
| 2   | S28625001 | 1    | ゴムバインダークミ    | RUBBER BINDER ASSY     |    |
| 2-1-3   | S28626001 | 1    | ゴムガイドLクミ     | RUBBER GUIDE (L) ASSY  |    |
| 2-1-3-1                                       | 141544001 | 2    | シメネジ3.18     | SCREW, M3.18           |    |
| 2-1-3-2                                       | 110215002 | 1    | シメネジ3.57     | SCREW, M3.57           |    |

From the library of: Diamond Needle Corp

M. プーラ装置関係 / Puller device mechanism / Ziehvorrichtung /  
 Mécanisme due puller / Mecanismo del dispositivo de arrastre

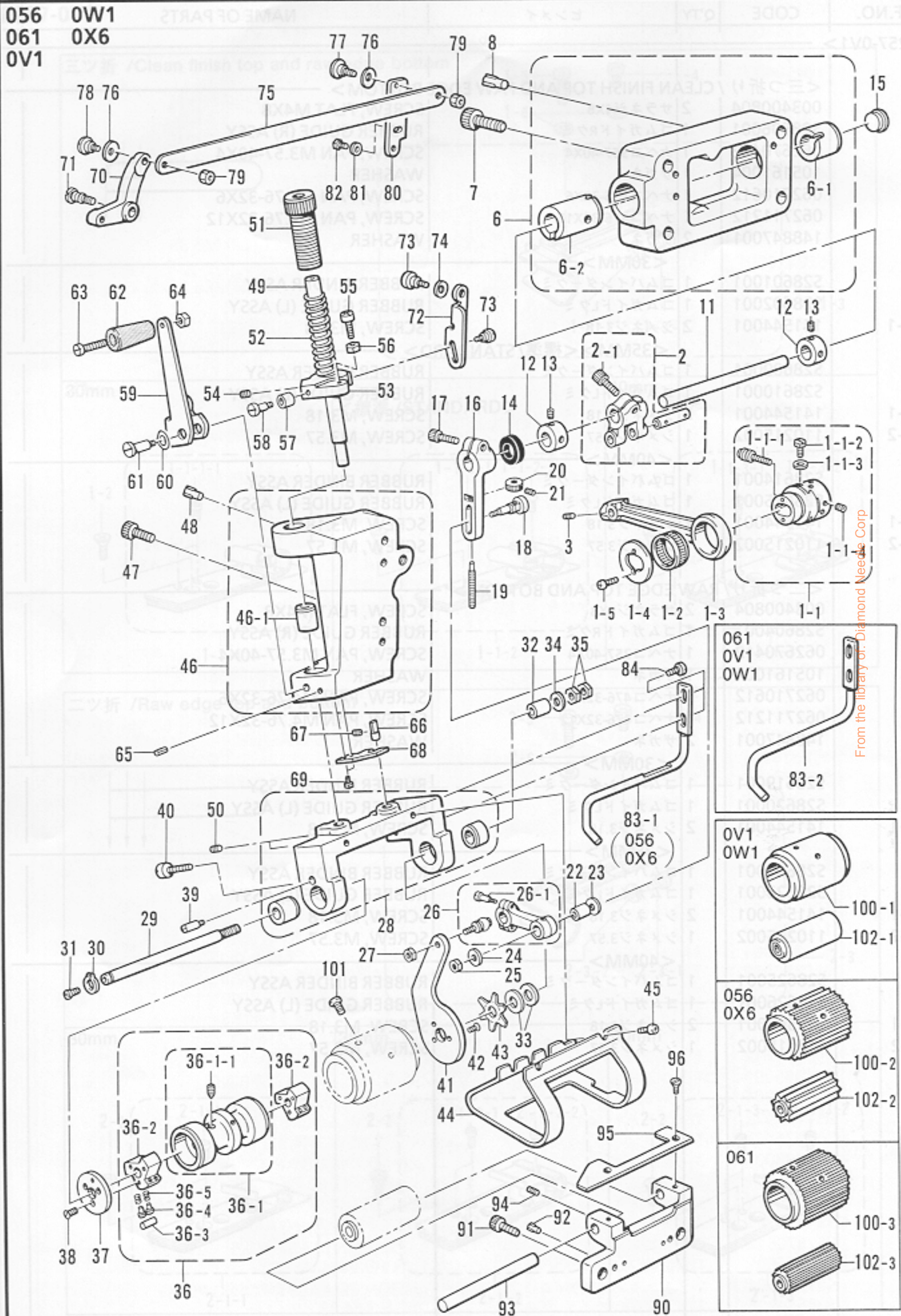

From the library of: Diamond Needle Corp

M. プーラ装置関係 / Puller device mechanism / Ziehvorrichtung /  
Mécanisme due puller / Mecanismo del dispositivo de arrastre

| REF.NO. | CODE      | Q'TY | ヒンメイ                  | NAME OF PARTS                   | RM |
|---------|-----------|------|-----------------------|---------------------------------|----|
|         |           |      | <056,061,0V1,0W1,0X6> |                                 |    |
| 1       | S13414201 | 1    | プーラヘンシンリンクロッドクミ       | PULLER ECCENTRIC WHEEL ROD ASSY |    |
| 1-1     | S12913201 | 1    | プーラヘンシンリンククミ          | PULLER ECCENTRIC WHEEL ASSY     |    |
| 1-1-1   | 113644001 | 1    | ヘンシンリンクチヨウセツネジ        | ADJUST SCREW                    |    |
| 1-1-2   | 144075001 | 2    | ボルト3.57               | BOLT, M3.57                     |    |
| 1-1-3   | 105161004 | 2    | ザガネ                   | WASHER                          |    |
| 1-1-4   | 014760622 | 3    | アナトメネジ5.95            | SET SCREW, SOCKET (CP) M5.95    |    |
| 1-2     | S12915001 | 1    | ニードルジクウケ25            | NEEDLE ROLLER BEARING 25        |    |
| 1-3     | S12916001 | 1    | プーラロッド                | PULLER ROD                      |    |
| 1-4     | S12821001 | 1    | レンカンオサエ               | CONNECTING ROD PRESSER          |    |
| 1-5     | 062630612 | 2    | ナベコ238-56X6           | SCREW, PAN M2.38-56X6           |    |
| 2       | S17773001 | 1    | クランクジクウデピンクミ          | CRANK LEVER PIN ASSY            |    |
| 2-1     | 018771432 | 1    | アナボルト635-40X14        | BOLT, SOCKET M6.35-40X14        |    |
| 3       | 014770622 | 1    | アナトメネジ6.35クボミ         | SET SCREW, SOCKET (CP) M6.35    |    |
| 6       | S28250001 | 1    | プーラブラケットRクミ           | PULLER BRACKET (R) ASSY         |    |
| 6-1     | 148120000 | 1    | クランクジクメタルR            | CRANK SHAFT BUSH (R)            |    |
| 6-2     | S28252000 | 1    | プーラドゥウジクメタルL          | PULLER DRIVING SHAFT BUSH (L)   |    |
| 7       | 018063022 | 4    | アナボルト6X30             | BOLT, SOCKET M6X30              |    |
| 8       | 117608001 | 2    | ミゾツキピン                | DOWEL PIN                       |    |
| 11      | S28253001 | 1    | プーラドゥウジク              | PULLER DRIVING SHAFT            |    |
| 12      | 140092001 | 2    | セットカラー                | SET COLLAR                      |    |
| 13      | 014680422 | 4    | アナトメネジ4.37クボミ         | SET SCREW, SOCKET (CP) M4.37    |    |
| 14      | S12918000 | 1    | ダストシール                | DUST SEAL                       |    |
| 15      | 159150009 | 1    | カマジクメクラセン             | OIL CAP                         |    |
| 16      | S12919001 | 1    | プーラドゥウレバー             | PULLER DRIVING LEVER            |    |
| 17      | 018061622 | 1    | アナボルト6X16             | BOLT, SOCKET M6X16              |    |
| 18      | S12920001 | 1    | プーラレンカンジク             | PULLER CONNECTING SHAFT         |    |
| 19      | S12921001 | 1    | チヨウセツネジ               | ADJUST SCREW                    |    |
| 20      | S12922001 | 1    | ツマミ                   | KNOB                            |    |
| 21      | 148294001 | 1    | アナトメネジ3.57クボミ         | SET SCREW, SOCKET (CP) M3.57    |    |
| 22      | S12923001 | 1    | レンカンスリーブ              | CONNECTING ROD SLEEVE           |    |
| 23      | 156265001 | 1    | ザガネ                   | WASHER                          |    |
| 24      | 107453001 | 1    | ザガネ                   | WASHER                          |    |
| 25      | 110140001 | 1    | ナット5.56               | NUT, M5.56                      |    |
| 26      | S12924001 | 1    | プーラレンカンクミ             | PULLER CONNECTING ROD ASSY      |    |
| 26-1    | 100526003 | 2    | ダンネジ3.57              | STUD SCREW, M3.57               |    |
| 27      | 110140001 | 1    | ナット5.56               | NUT, M5.56                      |    |
| 28      | S28254001 | 1    | プーラフレームクミ             | PULLER FRAME ASSY               |    |
| 29      | S28256001 | 1    | プーラジク                 | PULLER SHAFT                    |    |
| 30      | 048090142 | 1    | トメワジクヨウC9             | RETAINING RING, C9              |    |
| 31      | 107272002 | 1    | サラネジ4.37              | SCREW, FLAT M4.37               |    |
| 32      | S12933001 | 1    | プーラブツシュ               | PULLER BUSH                     |    |
| 33      | S02556001 | 2    | ザガネ                   | WASHER                          |    |
| 34      | 107153001 | 1    | ザガネ                   | WASHER                          |    |
| 35      | 105812003 | 2    | ナット7.94               | NUT, M7.94                      |    |
| 36      | S12934101 | 1    | プーラクラッチクミ             | PULLER CLUTCH ASSY              |    |
| 36-1    | S13415101 | 1    | プーラクラッチシュークミ          | PULLER CLUTCH SHOE ASSY         |    |
| 36-1-1  | 118853001 | 1    | アナトメネジ5.95            | SET SCREW, SOCKET M5.95         |    |
| 36-2    | S09039001 | 2    | クラッチツメ                | CLUTCH CLAW                     |    |
| 36-3    | 150604101 | 6    | コロ                    | ROLLER                          |    |
| 36-4    | 150605001 | 12   | クラッチピン                | CLUTCH PIN                      |    |
| 36-5    | S12900001 | 12   | クラッチバネ                | SPRING                          |    |
| 37      | S12936001 | 1    | クラッチタイタ               | CLUTCH PLATE                    |    |
| 38      | 106128004 | 3    | サラネジ3.57              | SCREW, FLAT M3.57               |    |
| 39      | S12937101 | 1    | スタッド                  | STUD                            |    |
| 40      | 121007001 | 1    | アタマツキトメネジ4.37         | SET SCREW, M4.37                |    |
| 41      | S28334001 | 1    | クラッチレバー               | CLUTCH LEVER                    |    |
| 42      | 106128004 | 3    | サラネジ3.57              | SCREW, FLAT M3.57               |    |
| 43      | S12939001 | 1    | ホシガタバネ                | SPRING                          |    |
| 44      | S28260001 | 1    | プーラガード                | PULLER GUARD                    |    |
| 45      | 062680612 | 4    | ナベコ4.37-40X6          | SCREW, PAN M4.37-40X6           |    |



M. プーラ装置関係 / Puller device mechanism / Ziehvorrichtung /  
 Mécanisme due puller / Mecanismo del dispositivo de arrastre

056 OW1  
 061 OX6  
 0V1

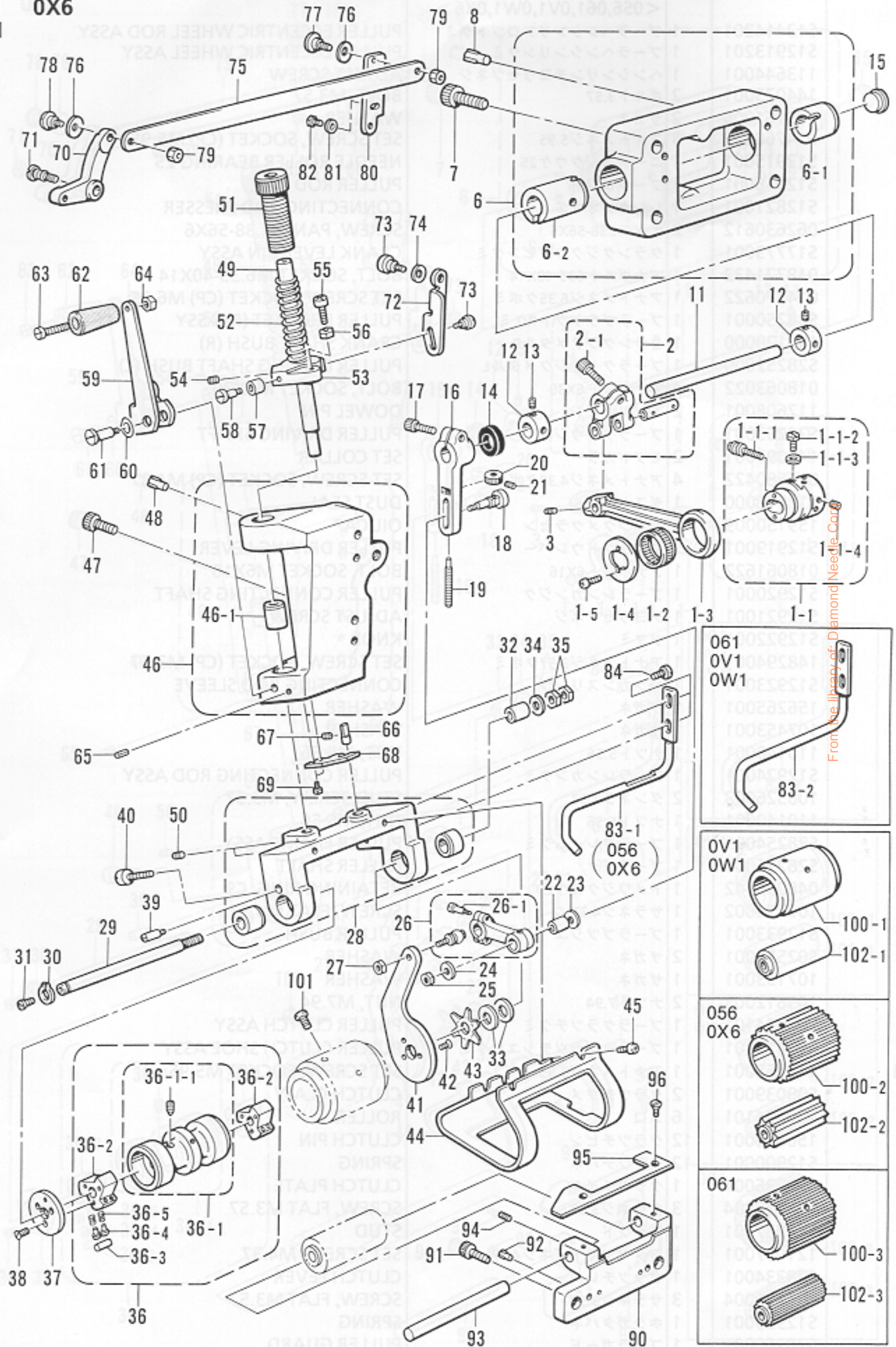

From the library of: Diamond Needle Corp.

M. プーラ装置関係 / Puller device mechanism / Ziehvorrichtung /  
Mécanisme due puller / Mecanismo del dispositivo de arrastre

| REF.NO. | CODE      | Q'TY | ヒンメイ                    | NAME OF PARTS                | RM |
|---------|-----------|------|-------------------------|------------------------------|----|
| 46      | S28261001 | 1    | プーラブラケットLクミ             | PULLER BRACKET (L) ASSY      |    |
| 46-1    | S12858000 | 1    | リテーナジクメタルF              | RETAINER SHAFT BUSH (F)      |    |
| 47      | 018061622 | 2    | アナボルト6X16               | BOLT, SOCKET M6X16           |    |
| 48      | 117608001 | 2    | ミゾツキピン                  | DOWEL PIN                    |    |
| 49      | S12942001 | 1    | プーラオサエボウ                | PULLER PRESSER BAR           |    |
| 50      | 014760622 | 2    | アナトメネジ5.95              | SET SCREW, SOCKET (CP) M5.95 |    |
| 51      | S12943001 | 1    | プーラアツチヨウセツネジ            | ADJUST SCREW                 |    |
| 52      | S28263001 | 1    | プーラオサエバネ                | PULLER SPRING                |    |
| 53      | S28264001 | 1    | プーラオサエボウダキ              | PULLER PRESSER BAR CLAMP     |    |
| 54      | 014770622 | 1    | アナトメネジ6.35クボミ           | SET SCREW, SOCKET (CP) M6.35 |    |
| 55      | 062682012 | 1    | ナベコ437-40X20            | SCREW, PAN M4.37-40X20       |    |
| 56      | 105234003 | 1    | ナット4.37                 | NUT, M4.37                   |    |
| 57      | 110167001 | 1    | コロ                      | ROLLER                       |    |
| 58      | 110168001 | 1    | コロジク                    | ROLLER SHAFT                 |    |
| 59      | S12946001 | 1    | プーラアゲレバー                | PULLER LIFTING LEVER         |    |
| 60      | 109239001 | 1    | ナミバネザガネ                 | WAVE SPRING WASHER           |    |
| 61      | S28333001 | 1    | ダンネジ5.95                | STUD SCREW, M5.95            |    |
| 62      | 159093009 | 1    | ハンドル                    | HANDLE                       |    |
| 63      | 112700001 | 1    | シメネジ5.95                | SCREW, M5.95                 |    |
| 64      | 106588003 | 1    | ナット5.95                 | NUT, M5.95                   |    |
| 65      | 047400842 | 1    | スプリングピンAW4X8            | PIN, SPRING ROLL AW4 x 8     |    |
| 66      | S28265001 | 1    | アンナイジク                  | GUIDE SHAFT                  |    |
| 67      | 014680422 | 1    | アナトメネジ4.37クボミ           | SET SCREW, SOCKET (CP) M4.37 |    |
| 68      | S28266001 | 1    | アンナイイタ                  | GUIDE PLATE                  |    |
| 69      | 017681012 | 2    | ボルト4.37X10              | BOLT, M4.37X10               |    |
| 70      | S28267001 | 1    | プーラアゲテコ                 | PULLER LIFTING LEVER         |    |
| 71      | S28268001 | 1    | ダンネジ7.94                | STUD SCREW, M7.94            |    |
| 72      | S28332001 | 1    | プーラアゲイタ                 | PULLER LIFTER PLATE          |    |
| 73      | 151987001 | 2    | ダンネジ4.37                | SHOULDER SCREW, M4.37        |    |
| 74      | 103810002 | 1    | ナミガタバネザガネ               | WAVE SPRING WASHER           |    |
| 75      | S28269001 | 1    | プーラレンケツイタ               | PULLER CONNECTING PLATE      |    |
| 76      | 103810002 | 2    | ナミガタバネザガネ               | WAVE SPRING WASHER           |    |
| 77      | 159238001 | 1    | ダンネジ4.37                | STUD SCREW 4.37              |    |
| 78      | 154149001 | 1    | カンケツオサエダンネジ             | STUD SCREW                   |    |
| 79      | 105234003 | 2    | ナット4.37                 | NUT, M4.37                   |    |
| 80      | S28270001 | 1    | チヨウセツイタ                 | CONTROL PLATE                |    |
| 81      | 148847001 | 2    | ザガネ                     | WASHER                       |    |
| 82      | 017681012 | 2    | ボルト4.37X10              | BOLT, M4.37X10               |    |
| 84      | 107407003 | 2    | シメネジ4.37                | SCREW, M4.37                 |    |
| 90      | S28273001 | 1    | シタローラドダイ                | LOWER ROLLER BASE            |    |
| 91      | 018061022 | 2    | アナボルト6X10               | BOLT, SOCKET M6X10           |    |
| 92      | 117608001 | 2    | ミゾツキピン                  | DOWEL PIN                    |    |
| 93      | S28274001 | 1    | シタローラジク                 | LOWER ROLLER SHAFT           |    |
| 94      | 014680422 | 2    | アナトメネジ4.37クボミ           | SET SCREW, SOCKET (CP) M4.37 |    |
| 95      | S28275001 | 1    | シタローラカバー                | LOWER ROLLER COVER           |    |
| 96      | S01696001 | 2    | サラネジ3.57X6              | SCREW, FLAT M3.57X6          |    |
| 101     | 102538002 | 3    | サラネジ3.57                | SCREW, FLAT M3.57            |    |
| 83-1    | S28271001 | 1    | <056,0X6><br>ゴムガイドA     | RUBBER GUIDE (A)             |    |
| 83-2    | S28272001 | 1    | <061,0V1,0W1><br>ゴムガイドB | RUBBER GUIDE (B)             |    |
| 100-1   | S28276000 | 1    | <0V1,0W1><br>ゴムローラU     | RUBBER ROLLER (U)            |    |
| 102-1   | S28279000 | 1    | ゴムローラDクミ<br><056,0X6>   | RUBBER ROLLER (D) ASSY       |    |
| 100-2   | S28277000 | 1    | プラスチックギヤU26             | PLASTIC GEAR (U26)           |    |
| 102-2   | S28282000 | 1    | プラスチックギヤD13<br><061>    | PLASTIC GEAR (D13)           |    |
| 100-3   | S28278000 | 1    | プラスチックギヤU30             | PLASTIC GEAR (U30)           |    |
| 102-3   | S28283000 | 1    | プラスチックギヤD15             | PLASTIC GEAR (D15)           |    |

N1. トリミングメス関係 / Trimming knife mechanism / Fadenabschneidemesseinheit /  
 Mécanisme de couteau rafraîchisseur / Mecanismo de cuchilla cortahilos

<右メス装置 / RIGHT KNIFE DEVICE>

0W1

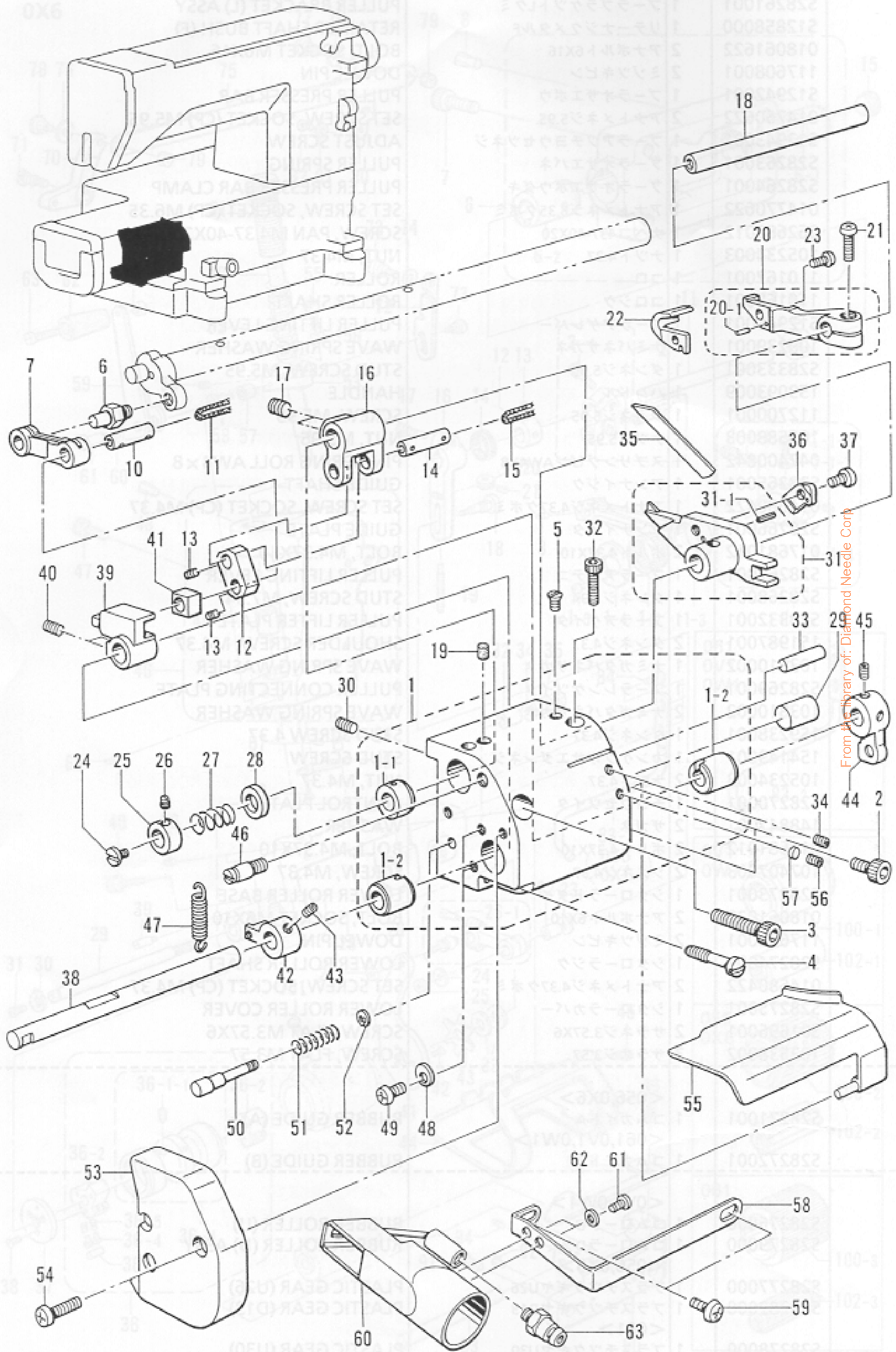

From the library of: Diamond Needle Corp

N1. トリミングメス関係 / Trimming knife mechanism / Fadenabschneidemesseinheit /  
 Mécanisme de couteau rafraîchisseur / Mecanismo de cuchilla cortahilos

| REF.NO. | CODE      | Q'TY | ヒンメイ          | NAME OF PARTS                | RM |
|---------|-----------|------|---------------|------------------------------|----|
|         |           |      | <0W1>         |                              |    |
| 1       | S28287001 | 1    | ミギメスドダイクミ     | RIGHT KNIFE BRACKET ASSY     |    |
| 1-1     | S28289000 | 1    | ウワメスジクメタル     | UPPER KNIFE SHAFT BUSH       |    |
| 1-2     | S28290000 | 2    | レバージクメタル      | LEVER SHAFT BUSH             |    |
| 2       | 018501022 | 2    | アナボルト5X10     | BOLT, SOCKET M5X10           |    |
| 3       | 018502522 | 1    | アナボルト5X25     | BOLT, SOCKET M5X25           |    |
| 4       | 102023005 | 1    | シメネジ4.37      | SCREW, M4.37                 |    |
| 5       | 108960002 | 1    | サラネジ3.57      | SCREW, FLAT M3.57            |    |
| 6       | S28292001 | 1    | メスクドウピン       | KNIFE DRIVING PIN            |    |
| 7       | S28293000 | 1    | ウワメスリンクL      | UPPER KNIFE LINK (L)         |    |
| 10      | S28295001 | 1    | リンクピンS        | LINK PIN (S)                 |    |
| 11      | 140430001 | 1    | クミヒモ (L = 40) | WICK (L = 40)                |    |
| 12      | S28297001 | 1    | ウワメスリンクS      | UPPER KNIFE LINK (S)         |    |
| 13      | 014680422 | 2    | アナトメネジ4.37クボミ | SET SCREW, SOCKET (CP) M4.37 |    |
| 14      | S28298001 | 1    | リンクピンL        | LINK PIN (L)                 |    |
| 15      | S23323001 | 1    | クミヒモ (L = 52) | WICK (L = 52)                |    |
| 16      | S28299000 | 1    | メスクドウウデ       | KNIFE DRIVING ARM            |    |
| 17      | 152718001 | 2    | アナトメネジ5.95    | SET SCREW, SOCKET M5.95      |    |
| 18      | S28300001 | 1    | ウワメスジク        | UPPER KNIFE SHAFT            |    |
| 19      | S09043000 | 1    | フェルト          | FELT                         |    |
| 20      | S28302001 | 1    | ウワメスホルダクミ     | UPPER KNIFE HOLDER ASSY      |    |
| 20-1    | 149604001 | 1    | ピン1.5X5.8     | PIN, 1.5X5.8                 |    |
| 21      | 062681212 | 1    | ナベコ437-40X12  | SCREW, PAN M4.37-40X12       |    |
| 22      | S28305001 | 1    | ウワメス          | UPPER KNIFE                  |    |
| 23      | 062300612 | 1    | ナベコ3X6        | SCREW, PAN M3X6              |    |
| 24      | 148834001 | 1    | シメネジ3.57      | SCREW, M3.57                 |    |
| 25      | 110243001 | 1    | ヌノオサエカラー      | COLLAR                       |    |
| 26      | 102716004 | 1    | トメネジ4.37      | SET SCREW, M4.37             |    |
| 27      | S28306001 | 1    | メスアツバネ        | SPRING                       |    |
| 28      | S12696001 | 1    | コロ            | ROLLER                       |    |
| 29      | S28307001 | 1    | アンナイジク        | GUIDE SHAFT                  |    |
| 30      | 014710522 | 1    | アナトメネジ4.76クボミ | SET SCREW, SOCKET (CP) M4.76 |    |
| 31      | S28308001 | 1    | シタメスホルダクミ     | LOWER KNIFE HOLDER ASSY      |    |
| 31-1    | 047140850 | 1    | スプリングピン1.4X8  | PIN, SPRING ROLL 1.4X8       |    |
| 32      | 018401422 | 1    | アナボルト4X14     | BOLT, SOCKET M4X14           |    |
| 33      | 153353001 | 1    | コロF5X19.8     | ROLLER (F), M5X19.8          |    |
| 34      | 014680422 | 1    | アナトメネジ4.37クボミ | SET SCREW, SOCKET (CP) M4.37 |    |
| 35      | S28310001 | 1    | シタメス          | LOWER KNIFE                  |    |
| 36      | S28311001 | 1    | シタメスオサエ       | LOWER KNIFE PRESSER          |    |
| 37      | 153208002 | 1    | シメネジ4.37      | SCREW, M4.37                 |    |
| 38      | S28312001 | 1    | ドロツブレバージク     | DROP LEVER SHAFT             |    |
| 39      | S28313001 | 1    | ドロツブレバー       | DROP LEVER                   |    |
| 40      | 014680422 | 2    | アナトメネジ4.37クボミ | SET SCREW, SOCKET (CP) M4.37 |    |
| 41      | S28314000 | 1    | カクゴマ          | SLIDE BLOCK                  |    |
| 42      | S28315001 | 1    | ドロツブウデ        | DROP ARM                     |    |
| 43      | 014680422 | 2    | アナトメネジ4.37クボミ | SET SCREW, SOCKET (CP) M4.37 |    |
| 44      | S28316001 | 1    | ドロツブテコ        | DROP LEVER                   |    |
| 45      | 014680422 | 2    | アナトメネジ4.37クボミ | SET SCREW, SOCKET (CP) M4.37 |    |
| 46      | 148144001 | 1    | バネカケ          | SPRING HOOK                  |    |
| 47      | S28317001 | 1    | ドロツブレバーバネ     | DROP LEVER SPRING            |    |
| 48      | S28318001 | 2    | ストツバ          | STOPPER                      |    |
| 49      | 062680712 | 2    | ナベコ437-40X7   | SCREW, PAN M4.37-40X7        |    |
| 50      | S28319001 | 1    | ストツバジク        | STOPPER SHAFT                |    |
| 51      | S28320001 | 1    | ストツバモドシバネ     | STOPPER SPRING               |    |
| 52      | 048030342 | 1    | トメワE3         | RETAINING RING, E3           |    |
| 53      | S28321001 | 1    | ミギメスドダイカバー    | RIGHT KNIFE BRACKET COVER    |    |
| 54      | 062681612 | 2    | ナベコ437-40X16  | SCREW, PAN M4.37-40X16       |    |
| 55      | S28322001 | 1    | ヌノガイド         | CLOTH GUIDE                  |    |
| 56      | 014680422 | 1    | アナトメネジ4.37クボミ | SET SCREW, SOCKET (CP) M4.37 |    |
| 57      | S11624000 | 1    | トメネジアテ        | SET SCREW PLATE              |    |
| 58      | S28323001 | 1    | キユウニユウカンササエ   | CHAIN SUCTION PIPE SUPPORT   |    |
| 59      | 062710712 | 2    | ナベコ476-32X7   | SCREW, PAN M4.76-32X7        |    |
| 60      | S28324001 | 1    | キユウニユウカンクミ    | CHAIN SUCTION PIPE ASSY      |    |
| 61      | 062670512 | 2    | ナベコ357-40X5   | SCREW, PAN M3.57-40X5        |    |
| 62      | 105248003 | 2    | ザガネ           | WASHER                       |    |
| 63      | S28742000 | 1    | ハーフユニオン       | HALF UNION                   |    |

N2. トリミングメス関係 / Trimming knife mechanism / Fadenabschneidemesseinheit /  
 Mécanisme de couteau rafraîchisseur / Mecanismo de cuchilla cortahilos

<左メス装置 / LEFT KNIFE DEVICE>

0X1  
 0X6

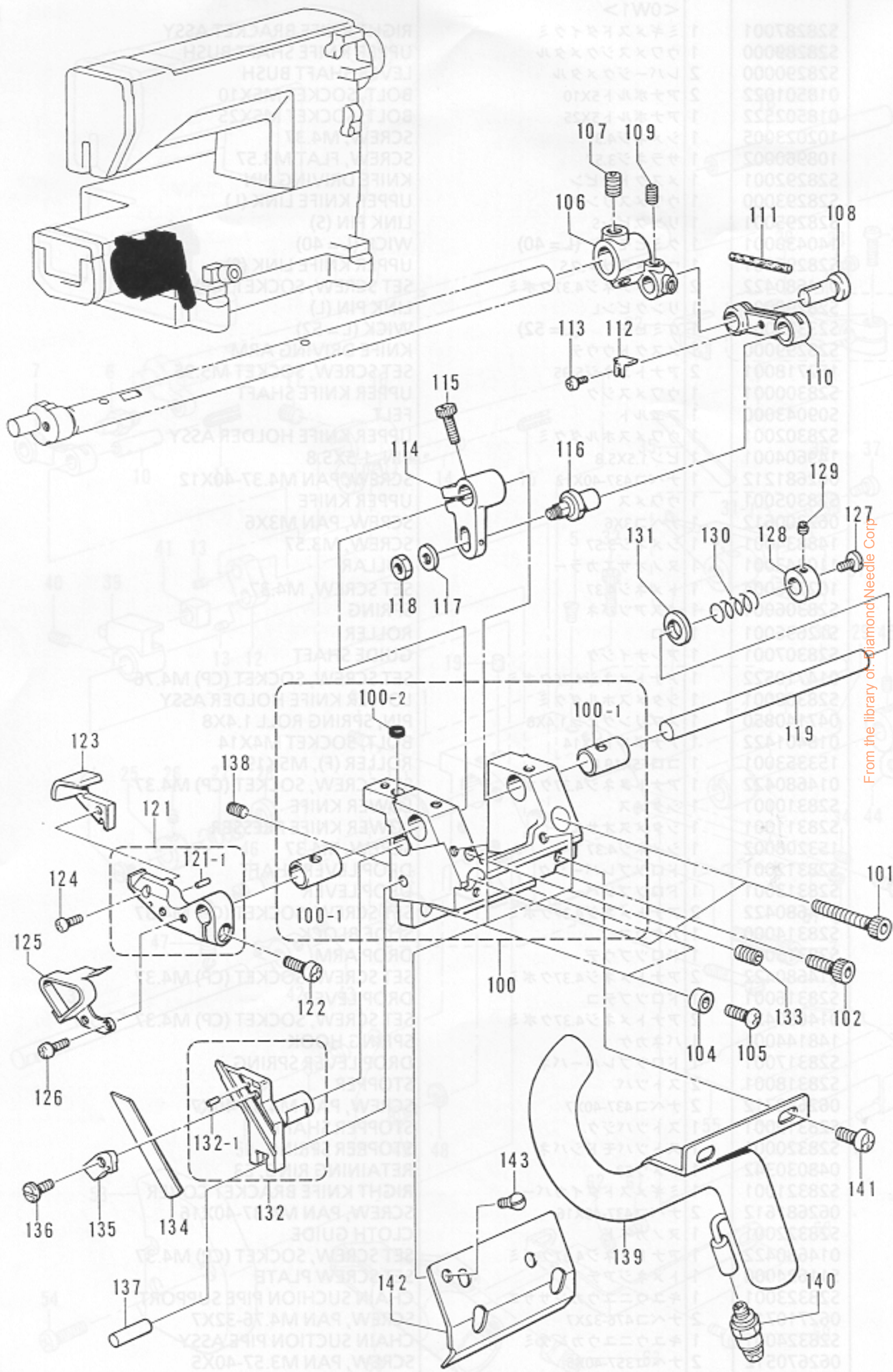

From the library of: DiamondNeedle Corp

N2. トリミングメス関係 / Trimming knife mechanism / Fadenabschneidemesseinheit /  
 Mécanisme de couteau rafraîchisseur / Mecanismo de cuchilla cortahilos

| REF.NO. | CODE      | Q'TY | ヒンメイ          | NAME OF PARTS                | RM |
|---------|-----------|------|---------------|------------------------------|----|
|         |           |      | <0X1,0X6>     |                              |    |
| 100     | S28336001 | 1    | ヒダリメスダイクミ     | LEFT KNIFE BRACKET ASSY      |    |
| 100-1   | S28338000 | 2    | ウワメスジクメタル     | UPPER KNIFE SHAFT BUSH       |    |
| 100-2   | S28820000 | 1    | ホジヨイタアテゴム     | SUPPORT PLATE RUBBER         |    |
| 101     | 018503022 | 2    | アナボルト5X30     | BOLT, SOCKET M5X30           |    |
| 102     | 018501422 | 1    | アナボルト5X14     | BOLT, SOCKET M5X14           |    |
| 104     | S09124001 | 2    | ハリイタササエイタカラー  | COLLER                       |    |
| 105     | S13385001 | 2    | シメネジ3.57X10   | SCREW, M3.57X10              |    |
| 106     | S28340001 | 1    | メスクドウウデ       | KNIFE DRIVING ARM            |    |
| 107     | 152718001 | 2    | アナトメネジ5.95    | SET SCREW, SOCKET M5.95      |    |
| 108     | S28353001 | 1    | ウワメスリンクジク     | UPPER KNIFE LINK SHAFT       |    |
| 109     | 014680422 | 2    | アナトメネジ4.37クボミ | SET SCREW, SOCKET (CP) M4.37 |    |
| 110     | S28341000 | 1    | ウワメスリンク       | UPPER KNIFE LINK             |    |
| 111     | S28342000 | 1    | フェルト          | FELT                         |    |
| 112     | S28231000 | 1    | フェルトオサエ       | FELT SUPPORT                 |    |
| 113     | 060630412 | 1    | バインド238-56X4  | SCREW, BIND M2.38-56X4       |    |
| 114     | S28343001 | 1    | メスクドウレバー      | KNIFE DRIVING LEVER          |    |
| 115     | 018681022 | 1    | アナボルト4.37X10  | BOLT, SOCKET M4.37X10        |    |
| 116     | S13809001 | 1    | スプレダロッドピン     | PIN                          |    |
| 117     | 148847001 | 1    | ザガネ           | WASHER                       |    |
| 118     | 110161006 | 1    | ナット4.76       | NUT, M4.76                   |    |
| 119     | S28344001 | 1    | ウワメスジク        | UPPER KNIFE SHAFT            |    |
| 121     | S28346001 | 1    | ウワメスホルダクミ     | UPPER KNIFE HOLDER ASSY      |    |
| 121-1   | 149604001 | 1    | ピン1.5X5.8     | PIN, 1.5X5.8                 |    |
| 122     | 062681212 | 1    | ナベコ437-40X12  | SCREW, PAN M4.37-40X12       |    |
| 123     | S28348001 | 1    | ウワメス          | UPPER KNIFE                  |    |
| 124     | 062300612 | 1    | ナベコ3X6        | SCREW, PAN M3X6              |    |
| 125     | S28349001 | 1    | キリクズアンナイ      | CHIP GUIDE                   |    |
| 126     | 062670612 | 2    | ナベコ357-40X6   | SCREW, PAN M3.57-40X6        |    |
| 127     | 148834001 | 1    | シメネジ3.57      | SCREW, M3.57                 |    |
| 128     | 110243001 | 1    | ヌノオサエカラー      | COLLAR                       |    |
| 129     | 102716004 | 1    | トメネジ4.37      | SET SCREW, M4.37             |    |
| 130     | S28306001 | 1    | メスアツバネ        | SPRING                       |    |
| 131     | S12696001 | 1    | コロ            | ROLLER                       |    |
| 132     | S28350001 | 1    | シタメスホルダクミ     | LOWER KNIFE HOLDER ASSY      |    |
| 132-1   | 047140850 | 1    | スプリングピン1.4X8  | PIN, SPRING ROLL 1.4X8       |    |
| 133     | 014710522 | 1    | アナトメネジ4.76クボミ | SET SCREW, SOCKET (CP) M4.76 |    |
| 134     | S28352001 | 1    | シタメス          | LOWER KNIFE                  |    |
| 135     | S28311001 | 1    | シタメスオサエ       | LOWER KNIFE PRESSER          |    |
| 136     | 153208002 | 1    | シメネジ4.37      | SCREW, M4.37                 |    |
| 137     | 153353001 | 1    | コロF5X19.8     | ROLLER (F), M5X19.8          |    |
| 138     | 014680422 | 1    | アナトメネジ4.37クボミ | SET SCREW, SOCKET (CP) M4.37 |    |
| 139     | S28354001 | 1    | キユウニユウカンクミ    | CHAIN SUCTION PIPE ASSY      |    |
| 140     | S28742000 | 1    | ハーフユニオン       | HALF UNION                   |    |
| 141     | 060680712 | 2    | バインド437-40X7  | SCREW, BIND M4.37-40X7       |    |
| 142     | S28061001 | 1    | ドダイカバー        | BRACKET COVER                |    |
| 143     | S09121001 | 2    | マルサラネジ3.57X6  | SCREW, FLAT M3.57X6          |    |

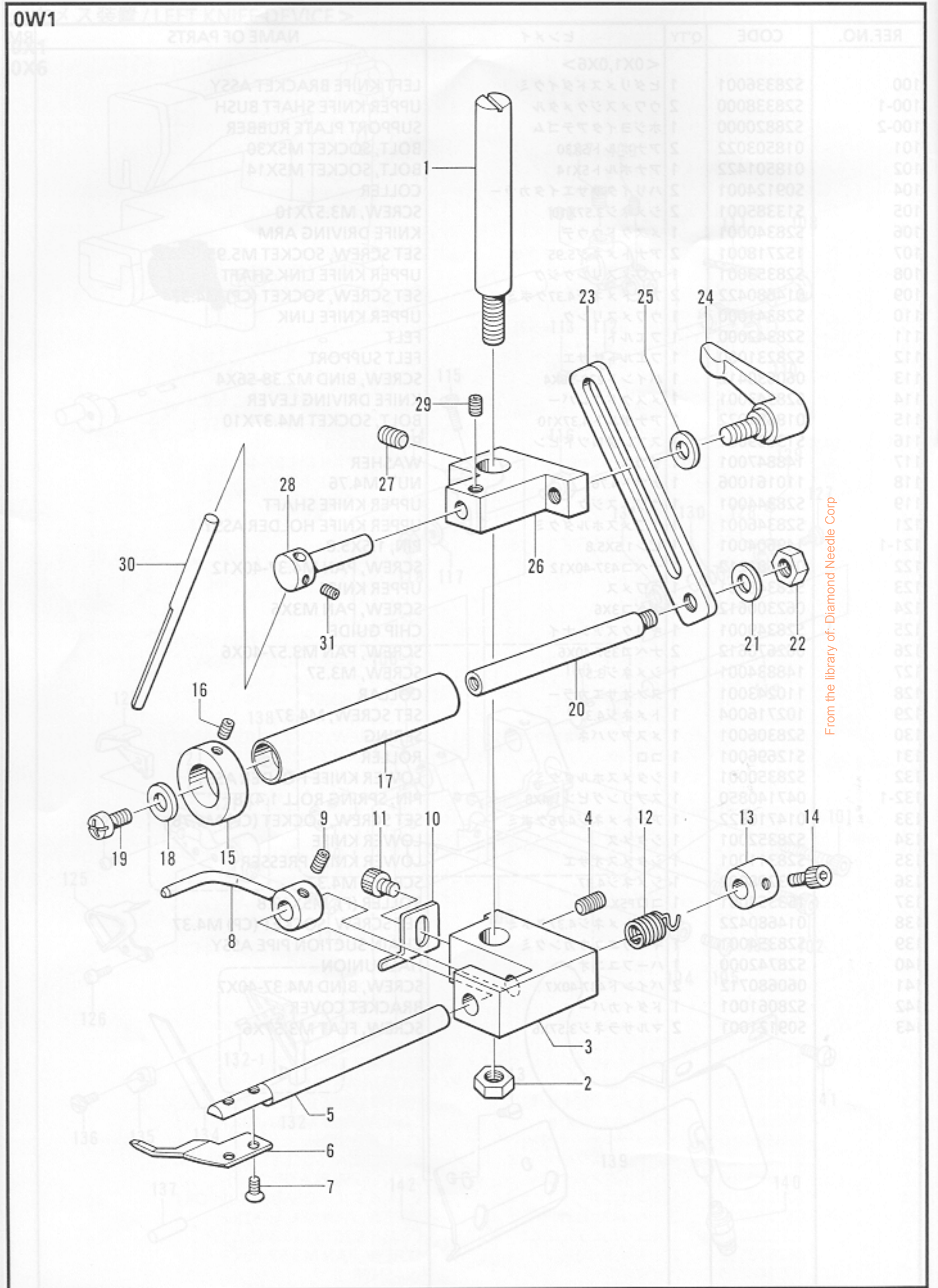

From the library of: Diamond Needle Corp

P. 縫製アタッチメント関係 / Sewing attachment mechanism / Zusatznähvorrichtung / Dispositif de couture / Dispositivo de costura

| REF.NO. | CODE      | Q'TY | ヒンメイ          | NAME OF PARTS                | RM |
|---------|-----------|------|---------------|------------------------------|----|
|         |           |      | <0W1>         | SYNCHRONIZER HOLDER #4       |    |
| 1       | S28629001 | 1    | ドダイササエ        | BASE SUPPORT                 |    |
| 2       | 021710202 | 1    | ナット2シユ4.76    | NUT, 2 M4.76                 |    |
| 3       | S28630001 | 1    | ヌノオサエドダイ      | CLOTH PRESSER BASE           |    |
| 4       | 014760622 | 1    | アナトメネジ5.95    | SET SCREW, SOCKET (CP) M5.95 |    |
| 5       | S28631001 | 1    | ヌノオサエジク       | CLOTH PRESSER SHAFT          |    |
| 6       | S28632001 | 1    | ヌノオサエ         | CLOTH PRESSER                |    |
| 7       | 141542001 | 2    | サラネジ3.18      | SCREW, FLAT M3.18            |    |
| 8       | S28633001 | 1    | ヌノオサエレバー      | CLOTH PRESSER LEVER          |    |
| 9       | 014680422 | 1    | アナトメネジ4.37クボミ | SET SCREW, SOCKET (CP) M4.37 |    |
| 10      | S28634001 | 1    | レバーストツバ       | LEVER STOPPER                |    |
| 11      | 018680522 | 1    | アナボルト4.37X5   | BOLT, SOCKET M4.37X5         |    |
| 12      | S28635001 | 1    | バネ            | SPRING                       |    |
| 13      | 147402001 | 1    | セットカラー        | SET COLLAR                   |    |
| 14      | 018680522 | 1    | アナボルト4.37X5   | BOLT, SOCKET M4.37X5         |    |
| 15      | S28636001 | 1    | セットカラー        | SET COLLAR                   |    |
| 16      | 014680422 | 1    | アナトメネジ4.37クボミ | SET SCREW, SOCKET (CP) M4.37 |    |
| 17      | S28637000 | 1    | ローラF          | ROLLER (F)                   |    |
| 18      | 025350332 | 1    | ヒラザガネダイ3.5    | WASHER, PLAIN L 3.5          |    |
| 19      | 062670612 | 1    | ナベコ357-40X6   | SCREW, PAN M3.57-40X6        |    |
| 20      | S28638001 | 1    | ローラFジク        | ROLLER (F) SHAFT             |    |
| 21      | 025710232 | 1    | ヒラザガネチユウ4.76  | WASHER, PLAIN M 4.76         |    |
| 22      | 021710202 | 1    | ナット2シユ4.76    | NUT, 2 M4.76                 |    |
| 23      | S28639001 | 1    | ローラFササエイタ     | ROLLER (F) SUPPORT PLATE     |    |
| 24      | S28640000 | 1    | クランプレバー       | CLAMP LEVER                  |    |
| 25      | 025710232 | 1    | ヒラザガネチユウ4.76  | WASHER, PLAIN M 4.76         |    |
| 26      | S28641001 | 1    | ゴムガイドドダイ      | RUBBER GUIDE BASE            |    |
| 27      | 014760622 | 1    | アナトメネジ5.95    | SET SCREW, SOCKET (CP) M5.95 |    |
| 28      | S28642001 | 1    | ゴムガイドホルダ      | RUBBER GUIDE HOLDER          |    |
| 29      | 014680422 | 1    | アナトメネジ4.37クボミ | SET SCREW, SOCKET (CP) M4.37 |    |
| 30      | S28643001 | 1    | ゴムガイド         | RUBBER GUIDE                 |    |
| 31      | 146427001 | 1    | アナトメネジ3.18クボミ | SET SCREW, SOCKET (CP) M3.18 |    |

From the library of: Diamond Needle Corp



Q. 針位置検出器関係 / Synchronizer / Synchronisator / Synchronisateur / Sincronizador

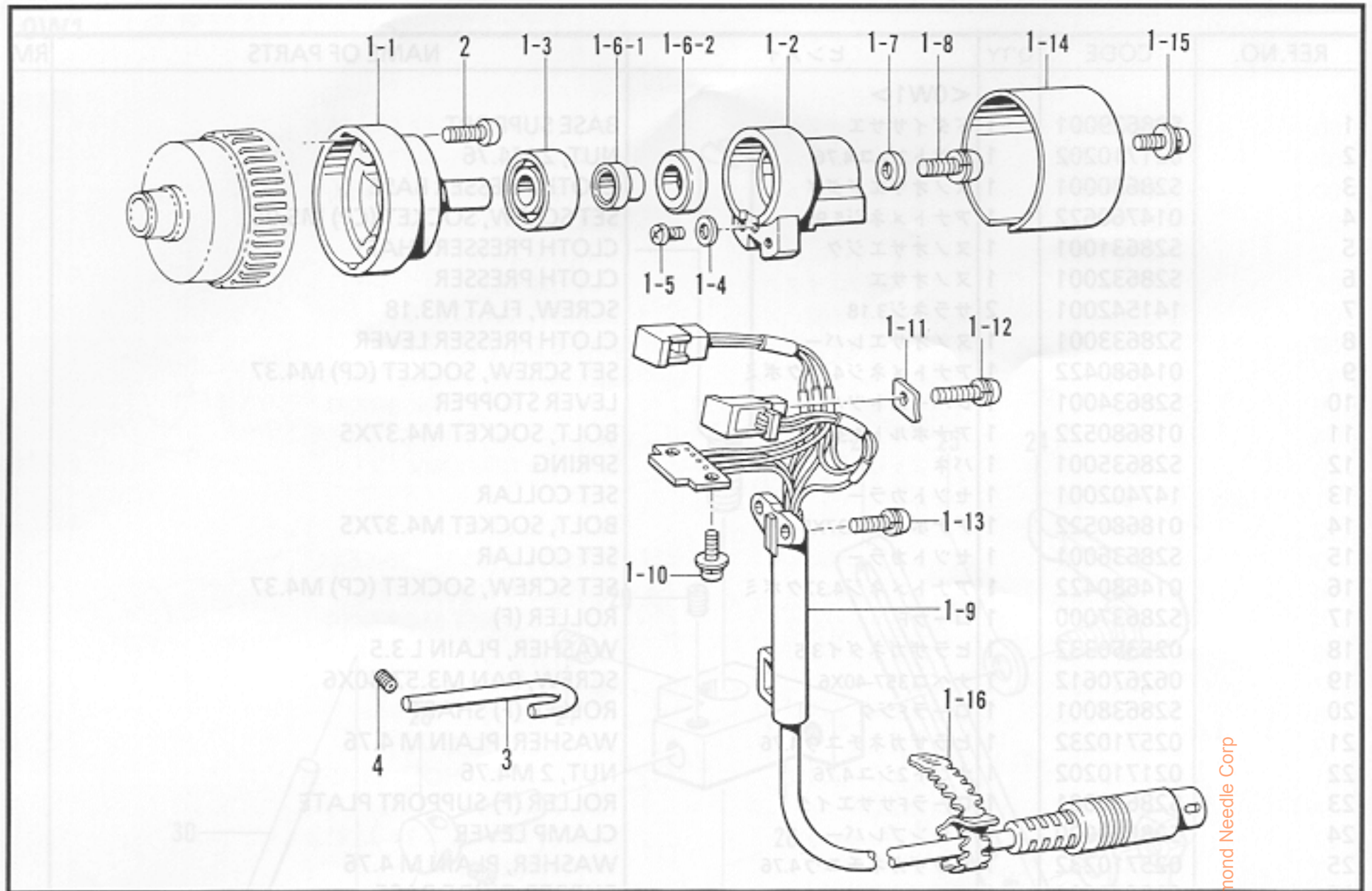

118-256-257-501

R. 糸払い関係 / Thread wiper mechanism / Fadenwischvorrichtung / Mécanisme de tire-fil / Mecanismo del limpiador de hilo

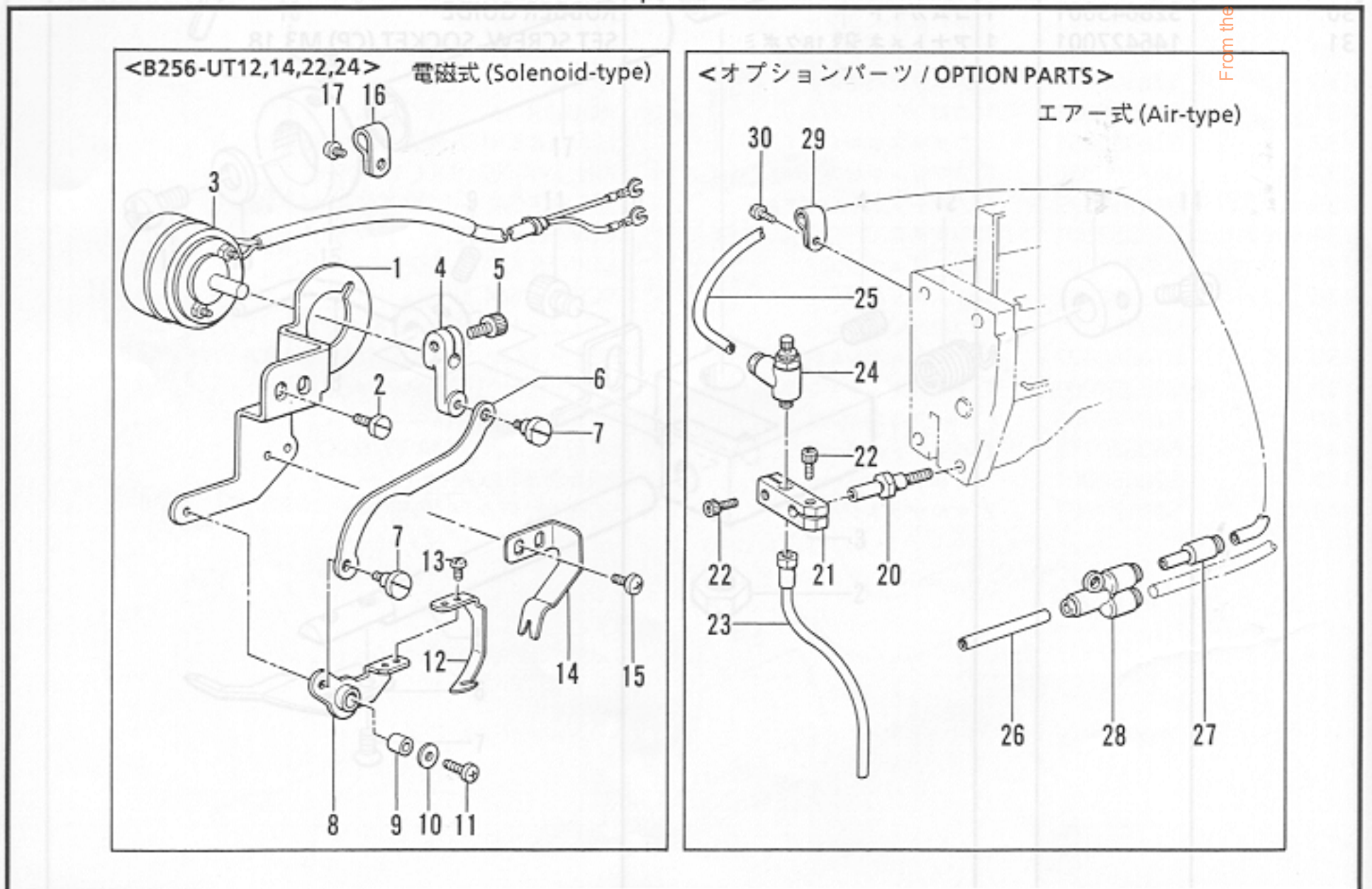

From the library of: Diamond Needle Corp

118-256-405

Q. 針位置検出器関係 / Synchronizer / Synchronisator / Synchronisateur / Sincronizador

| REF.NO. | CODE      | Q'TY | ヒンメイ           | NAME OF PARTS                 | RM |
|---------|-----------|------|----------------|-------------------------------|----|
| 1       | J00102001 | 1    | シンクロナイザクミ#15G7 | SYNCHRONIZER ASSY #15G7       |    |
| 1-1     | 234141001 | 1    | ジシヤク.ジククミ#4-1  | MAGNET STUD ASSY #4-1         |    |
| 1-2     | 234143001 | 1    | ケンシユツキホルダー#4   | SYNCHRONIZER HOLDER #4        |    |
| 1-3     | 076000600 | 1    | タマジクウケ6000VV   | BALL BEARING 6000VV           |    |
| 1-4     | 025030335 | 1    | ヒラザガネダイ3       | WASHER, PLAIN L 3             |    |
| 1-5     | 215083001 | 1    | +ナベセット3X6D     | SCREW, PAN (S WASHER) M3X6D   |    |
| 1-6     | 234144001 | 1    | ジシヤク18.7クミ     | MAGNET 18.7 ASSY              |    |
| 1-6-1   | 234145001 | 1    | ジシヤクトリツケダイ#2   | MAGNET SET BRACKET #2         |    |
| 1-6-2   | 219558000 | 1    | ジシヤク12X18.7X6  | MAGNET (12X18.7X6)            |    |
| 1-7     | 234146001 | 1    | ワ2X5.1X12ST    | WASHER (2X5.1X12ST)           |    |
| 1-8     | 211528001 | 1    | +ナベセットネジ5X12   | SCREW, PAN (S WASHER) M5X12   |    |
| 1-9     | J00103001 | 1    | ソシコードクミG15-2   | ELEMENT CORD ASSY G15-2       |    |
| 1-10    | 230100001 | 2    | +ナベセット3X6DB    | SCREW, PAN (S WASHER) M3X6DB  |    |
| 1-11    | 234153001 | 2    | オサエカナグ         | PRESSER PLATE                 |    |
| 1-12    | 216870001 | 2    | +ナベセット4X16D    | SCREW, PAN (S WASHER) M4X16D  |    |
| 1-13    | 215082001 | 2    | +ナベセット4X12DA   | SCREW, PAN (S WASHER) M4X12DA |    |
| 1-14    | 234154002 | 1    | シンクロナイザカバー#5   | SYNCHRONIZER COVER #5         |    |
| 1-15    | 216410003 | 2    | +ナベセット4X10DB   | SCREW, PAN (S WASHER) M4X10DB |    |
| 1-16    | 226391001 | 1    | コードバンド         | CORD BAND                     |    |
| 2       | 062711212 | 2    | ナベコ476-32X12   | SCREW, PAN M4.76-32X12        |    |
| 3       | S21941001 | 1    | シンクロナイザガイド     | SYNCHRONIZER GUIDE            |    |
| 4       | 014680622 | 1    | アナトメネジ4.37クボミ  | SET SCREW, SOCKET (CP) M4.37  |    |

118-256,257-501

R. 糸払い関係 / Thread wiper mechanism / Fadenwischvorrichtung / Mécanisme de tire-fil / Mecanismo del limpiador de hilo

| REF.NO.                 | CODE      | Q'TY | ヒンメイ             | NAME OF PARTS              | RM |
|-------------------------|-----------|------|------------------|----------------------------|----|
| <B256-UT12,14,22,24>    |           |      |                  |                            |    |
| 1                       | S21867001 | 1    | イトハライドダイ         | THREAD WIPER BRACKET       |    |
| 2                       | 100644005 | 2    | シメネジ4.37         | SCREW, M4.37               |    |
| 3                       | S21868101 | 1    | イトハライソレノイドクミ     | THREAD WIPER SOLENOID ASSY |    |
| 4                       | S21871101 | 1    | イトハライレバー         | THREAD WIPER LEVER         |    |
| 5                       | 018681022 | 1    | アナボルト4.37X10     | BOLT, SOCKET M4.37X10      |    |
| 6                       | S21872101 | 1    | イトハライロッド         | THREAD WIPER ROD           |    |
| 7                       | 105237002 | 2    | ダンネジ3.57         | STUD SCREW 3.57            |    |
| 8                       | S21873001 | 1    | イトハライクランク        | THREAD WIPER CRANK         |    |
| 9                       | S21874000 | 1    | シテンジク            | FULCRUM SHAFT              |    |
| 10                      | S21875001 | 1    | ザガネ              | WASHER                     |    |
| 11                      | 062670812 | 1    | ナベコ3.57-40X8     | SCREW, PAN M3.57-40X8      |    |
| 12                      | S21876001 | 1    | イトハライ            | THREAD WIPER               |    |
| 13                      | 062630412 | 2    | ナベコ238-56X4      | SCREW, PAN M2.38-56X4      |    |
| 14                      | S21877001 | 1    | イトツカミバネ          | THREAD CLAMP SPRING        |    |
| 15                      | 060670512 | 2    | バインド357-40X5     | SCREW, BIND M3.57-40X5     |    |
| 16                      | 149547000 | 5    | コードオサエ           | CORD HOLDER (4N)           |    |
| 17                      | 062680712 | 5    | ナベコ437-40X7      | SCREW, PAN M4.37-40X7      |    |
| <オプションパーツ/OPTION PARTS> |           |      |                  |                            |    |
| 20                      | S28897001 | 1    | ワイバードダイジク        | WIPER BRACKET SHAFT        |    |
| 21                      | S28898001 | 1    | ワイバードダイ          | WIPER BRACKET              |    |
| 22                      | 018681022 | 2    | アナボルト4.37X10     | BOLT, SOCKET M4.37X10      |    |
| 23                      | S28899001 | 1    | ワイバークミ           | WIPER ASSY                 |    |
| 24                      | S23660000 | 1    | スピードコントローラ       | SPEED CONTROLLER           |    |
| 25                      | S14085011 | 1    | エアーチューブ (L=1410) | AIR TUBE (L=1410)          |    |
| 26                      | S28744000 | 1    | エアーチューブ (L=40)   | AIR TUBE (L=40)            |    |
| 27                      | S28902000 | 1    | レジュース04-06       | REDUCER 04-06              |    |
| 28                      | S24021000 | 1    | ユニオンワイ6          | UNION 6                    |    |
| 29                      | S10243000 | 5    | ナイロンクランプNK-3N    | CORD HOLDER (NK-3N)        |    |
| 30                      | 062680712 | 5    | ナベコ437-40X7      | SCREW, PAN M4.37-40X7      |    |

参照番号 / Ref. No.

R-1~17 (電磁式 / Solenoid-type)

R-20~30 (エアー式 / Air-type)

糸払いセット / Thread wiper set

183821-101

S28896-001

S1. 下飾り糸切り関係 / Lower thread trimmer mechanism / Unterefadensabschneider /  
 Mécanisme de coupe-fils inférieur / Dispositivo de cortahilos inferior

B256-UT11,12,13,14  
 B257-UT11,13,32,34

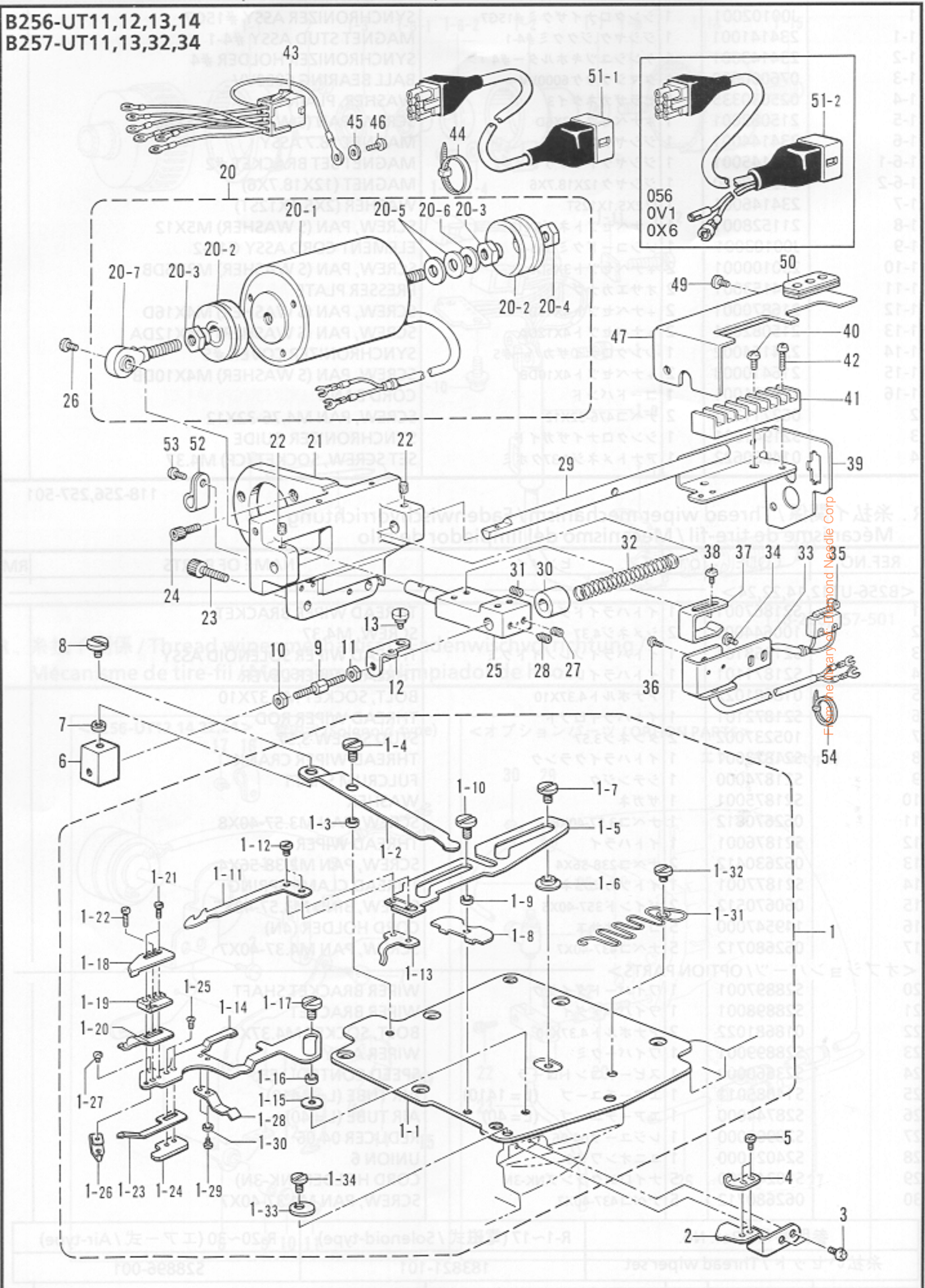

S1. 下飾り糸切り関係 / Lower thread trimmer mechanism / Unterefadensabschneider / Mécanisme de coupe-fils inférieur / Dispositivo de cortahilos inferior

| REF.NO. | CODE      | Q'TY | ヒンメイ   | NAME OF PARTS                            | RM |
|---------|-----------|------|--|--|----|
|         |           |      | <B256-UT11,12,13,14><br><B257-UT11,13,32,34> | BOLT, SOCKET M6X20<br>BOLT, SOCKET M6X20 |    |
| 1       | S28797101 | 1    | シタカザライトキリクミ                                  | LOWER THREAD TRIMMER ASSY                |    |
| 1-1     | S28490001 | 1    | ベッドウワカバーC                                    | BED UPPER COVER (C)                      |    |
| 1-2     | S28644001 | 1    | シタメスクドウレバー                                   | LOWER KNIFE DRIVING LEVER                |    |
| 1-3     | S28645001 | 1    | カラー  | COLLAR                                   |    |
| 1-4     | S28646001 | 1    | シメネジ3.57                                     | SCREW, M3.57                             |    |
| 1-5     | S28647001 | 1    | シタメスドダイ                                      | LOWER KNIFE BASE                         |    |
| 1-6     | S28648001 | 1    | ガイドチヨウセツタイ                                   | GUIDE ADJUST PLATE                       |    |
| 1-7     | S28646001 | 1    | シメネジ3.57                                     | SCREW, M3.57                             |    |
| 1-8     | S28649000 | 1    | ドダイスライドイタA                                   | BASE SLIDE PLATE (A)                     |    |
| 1-9     | S28645001 | 1    | カラー  | COLLAR                                   |    |
| 1-10    | S28646001 | 1    | シメネジ3.57                                     | SCREW, M3.57                             |    |
| 1-11    | S28650101 | 1    | シタメス   | LOWER KNIFE                              |    |
| 1-12    | 106568003 | 2    | シメネジ3.57                                     | SCREW, M3.57                             |    |
| 1-13    | S28651001 | 1    | イトトリイタ                                       | THREAD TAKE-UP PLATE                     |    |
| 1-14    | S28652001 | 1    | ウワメスドダイ                                      | UPPER KNIFE BASE                         |    |
| 1-15    | S28653000 | 1    | ドダイスライドイタB                                   | BASE SLIDE PLATE (B)                     |    |
| 1-16    | S28645001 | 1    | カラー  | COLLAR                                   |    |
| 1-17    | S28646001 | 1    | シメネジ3.57                                     | SCREW, M3.57                             |    |
| 1-18    | S28654001 | 1    | ウワメス   | UPPER KNIFE                              |    |
| 1-19    | S28655001 | 1    | シタメスガイド                                      | LOWER KNIFE GUIDE                        |    |
| 1-20    | S28656101 | 1    | イトツカミバネ                                      | THREAD CLAMP SPRING                      |    |
| 1-21    | S28657001 | 2    | シメネジ2.38X6.5                                 | SCREW, M2.38X6.5                         |    |
| 1-22    | S28658001 | 1    | シメネジ2.38X9.5                                 | SCREW, M2.38X9.5                         |    |
| 1-23    | S28659101 | 1    | イトツカミチヨウセツバネ                                 | THREAD CLAMP ADJUST SPRING               |    |
| 1-24    | S28660001 | 1    | バネトリツケイタ                                     | SPRING SET PLATE                         |    |
| 1-25    | S01694001 | 2    | サラネジ2.38X4                                   | SCREW, FLAT M2.38X4                      |    |
| 1-26    | S28661001 | 1    | イトツカミチヨウセツタイ                                 | THREAD CLAMP ADJUST PLATE                |    |
| 1-27    | S01295001 | 1    | シメネジ2.38X3.5                                 | SCREW, M2.38X3.5                         |    |
| 1-28    | S28662001 | 1    | ウワメスドダイササエバネ                                 | UPPER KNIFE BASE SUPPORT SPRING          |    |
| 1-29    | 100105005 | 2    | シメネジ2.38                                     | SCREW, M2.38                             |    |
| 1-30    | 025630132 | 2    | ヒラザガネシヨウ2.38                                 | WASHER, PLAIN S 2.38                     |    |
| 1-31    | S28663001 | 1    | ウワメスドダイオシバネ                                  | SPRING                                   |    |
| 1-32    | 101671002 | 1    | シメネジ4.37                                     | SCREW, M4.37                             |    |
| 1-33    | S28318001 | 1    | ストツパ   | STOPPER                                  |    |
| 1-34    | 106629002 | 1    | シメネジ4.37                                     | SCREW, M4.37                             |    |
| 2       | S28665001 | 1    | ガイドイタA                                       | GUIDE PLATE (A)                          |    |
| 3       | 060680712 | 2    | バインド437-40X7                                 | SCREW, BIND M4.37-40X7                   |    |
| 4       | S28666001 | 1    | ガイドイタB                                       | GUIDE PLATE (B)                          |    |
| 5       | 062670412 | 2    | ナベコ357-40X4                                  | SCREW, PAN M3.57-40X4                    |    |
| 6       | S28667001 | 1    | クドウレンカンブロック                                  | DRIVING CONNECTING BLOCK                 |    |
| 7       | S28645001 | 1    | カラー  | COLLAR                                   |    |
| 8       | S28646001 | 1    | シメネジ3.57                                     | SCREW, M3.57                             |    |
| 9       | S21906001 | 1    | クドウレンカンジク                                    | DRIVING CONNECTING SHAFT                 |    |
| 10      | 110140001 | 1    | ナツト5.56                                      | NUT, M5.56                               |    |
| 11      | S21907001 | 1    | ナツト5.56                                      | NUT, M5.56                               |    |
| 12      | S28668001 | 1    | クドウレンカンイタ                                    | DRIVING CONNECTING PLATE                 |    |
| 13      | 159908001 | 1    | ダンネジ4.37                                     | STUD SCREW, M4.37                        |    |
| 20      | S21895001 | 1    | イトキリソレノイドクミ                                  | THREAD TRIMMER SOLENOID ASSY             |    |
| 20-1    | S21896001 | 1    | イトキリソレノイド                                    | THREAD TRIMMER SOLENOID                  |    |
| 20-2    | S21897000 | 2    | ゴムブーツ  | RUBBER BOOT                              |    |
| 20-3    | S21898001 | 2    | ナツト8   | NUT, M8                                  |    |
| 20-4    | 021080302 | 1    | ナツト3シユ8                                      | NUT, 3 M8                                |    |
| 20-5    | S21899000 | 2    | ストツパゴム                                       | RUBBER STOPPER                           |    |
| 20-6    | 025080232 | 1    | ヒラザガネチユウ8                                    | WASHER, PLAIN M 8                        |    |
| 20-7    | S21900001 | 1    | ロツドエンド                                       | ROD END                                  |    |
| 21      | S21901001 | 1    | イトキリソレノイドドダイ                                 | THREAD TRIMMER SOLENOID BRACKET          |    |
| 22      | S09043000 | 2    | フェルト   | FELT                                     |    |

S1. 下飾り糸切り関係 / Lower thread trimmer mechanism / Unterefadenabschneider /  
 Mécanisme de coupe-fils inférieur / Dispositivo de cortahilos inferior

B256-UT11,12,13,14  
 B257-UT11,13,32,34

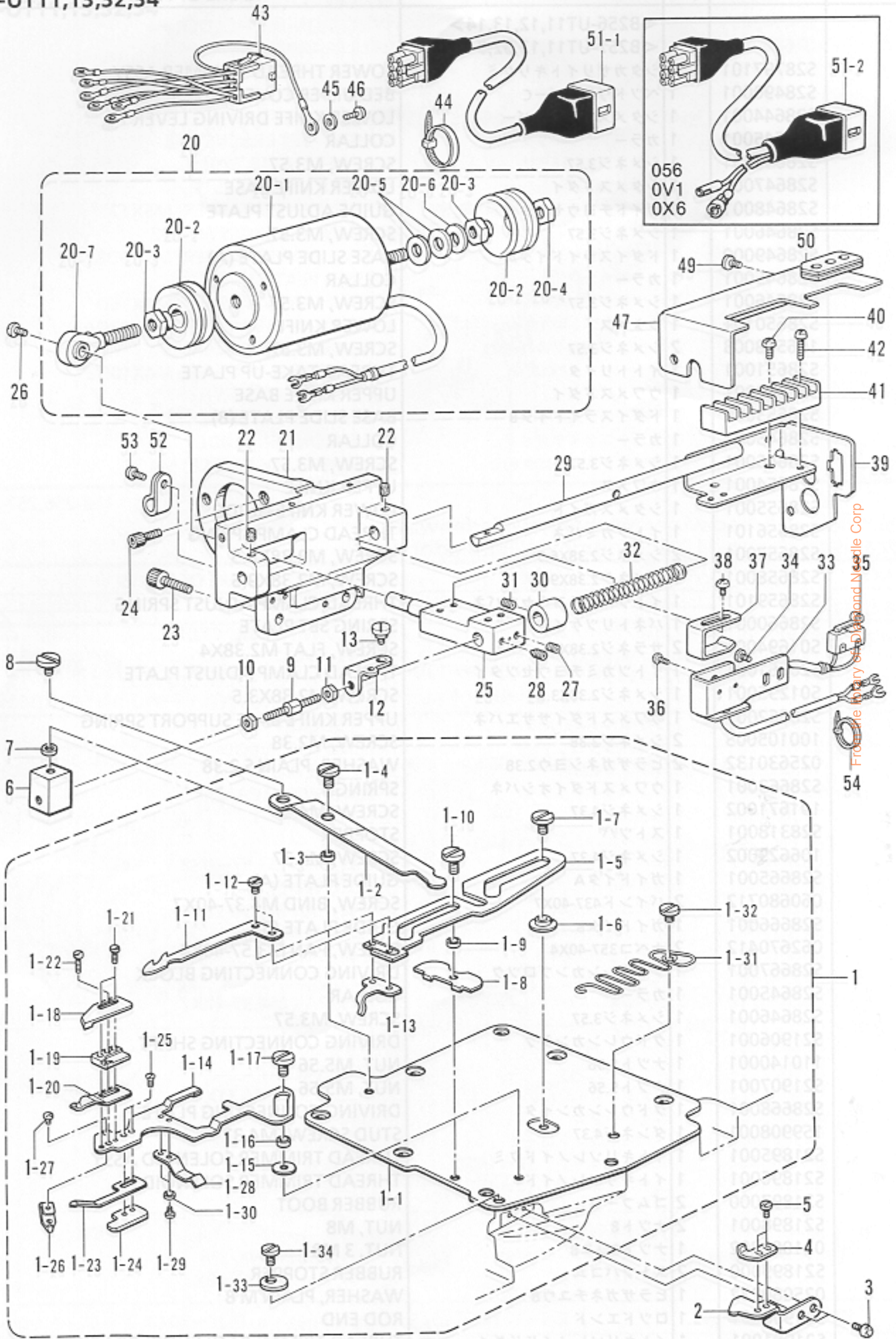

From the library of J. P. Bond and Needle Corp

S1. 下飾り糸切り関係 / Lower thread trimmer mechanism / Unterefadensabschneider / Mécanisme de coupe-fils inférieur / Dispositivo de cortahilos inferior

| REF.NO. | CODE      | Q'TY | ヒンメイ          | NAME OF PARTS                | RM |
|---------|-----------|------|---------------|------------------------------|----|
| 23      | 018062022 | 2    | アナボルト6X20     | BOLT, SOCKET M6X20           |    |
| 24      | 018501222 | 3    | アナボルト5X12     | BOLT, SOCKET M5X12           |    |
| 25      | S21902001 | 1    | イトキリクドウウデ     | THREAD TRIMMER DRIVING ARM   |    |
| 26      | 062680512 | 1    | ナベコ437-40X5   | SCREW, PAN M4.37-40X5        |    |
| 27      | 014760622 | 1    | アナトメネジ5.95    | SET SCREW, SOCKET (CP) M5.95 |    |
| 28      | 118853001 | 1    | アナトメネジ5.95    | SET SCREW, SOCKET M5.95      |    |
| 29      | S21903001 | 1    | イトキリクドウジク     | THREAD TRIMMER DRIVING SHAFT |    |
| 30      | 104521002 | 1    | セツトカラー        | SET COLLAR                   |    |
| 31      | 014770622 | 1    | アナトメネジ6.35クボミ | SET SCREW, SOCKET (CP) M6.35 |    |
| 32      | S21904101 | 1    | イトキリフツキバネ     | CARRIAGE RETURN SPRING       |    |
| 33      | S21933001 | 1    | スイッチダイ        | SWITCH BASE                  |    |
| 34      | 060680712 | 2    | バインド437-40X7  | SCREW, BIND M4.37-40X7       |    |
| 35      | S21934001 | 1    | スイッチクミ        | SWITCH ASSY                  |    |
| 36      | 062020805 | 2    | ナベコ2X8        | SCREW, PAN M2X8              |    |
| 37      | S21935001 | 1    | スイッチイタ        | SWITCH PLATE                 |    |
| 38      | 060680712 | 2    | バインド437-40X7  | SCREW, BIND M4.37-40X7       |    |
| 39      | S28759001 | 1    | コネクタターミナル     | CONNECTOR TERMINAL           |    |
| 40      | 060680712 | 4    | バインド437-40X7  | SCREW, BIND M4.37-40X7       |    |
| 41      | S21937001 | 1    | タンシダイ         | TERMINAL BLOCK               |    |
| 42      | 062301616 | 2    | ナベコM3X16      | SCREW, PAN M3X16             |    |
| 43      | S21938001 | 1    | コードクミ         | CORD ASSY                    |    |
| 44      | S04159000 | 1    | バインド1M        | BAND (1M)                    |    |
| 45      | S02745001 | 1    | ザガネ           | WASHER                       |    |
| 46      | 062680663 | 1    | ナベコ437-40X6   | SCREW, PAN M4.37-40X6        |    |
| 47      | S28760001 | 1    | コネクタカバー       | CONNECTOR COVER              |    |
| 49      | 060680512 | 3    | バインド437-40X5  | SCREW, BIND M4.37-40X5       |    |
| 50      | 233193001 | 1    | テモトコードブツシグ    | CORD BUSH                    |    |
| 51-1    | S21940101 | 1    | ケーブルクミ        | CABLE ASSY                   |    |
| 52      | S25907000 | 1    | コードホルダ#9      | CORD HOLDER (9N)             |    |
| 53      | 062680712 | 1    | ナベコ437-40X7   | SCREW, PAN M4.37-40X7        |    |
| 54      | S04159000 | 1    | バインド1M        | BAND (1M)                    |    |
| 51-2    | S28669001 | 1    | ケーブルクミ        | CABLE ASSY                   |    |
|         |           |      | <056,0V1,0X6> | WASHER, PLAIN S 2.38         |    |
|         |           |      |               | SCREW, PAN M4.37             |    |
|         |           |      |               | STOPPER                      |    |
|         |           |      |               | SCREW, M4.37                 |    |
|         |           |      |               | GUIDE PLATE (A)              |    |
|         |           |      |               | SCREW, BIND M4.37-40X7       |    |
|         |           |      |               | GUIDE PLATE (B)              |    |
|         |           |      |               | SCREW, PAN M4.37-40X5        |    |
|         |           |      |               | DRIVING-CONNECTING BLOCK     |    |
|         |           |      |               | COLLAR                       |    |
|         |           |      |               | SCREW, M3.57                 |    |
|         |           |      |               | DRIVING-CONNECTING SHAFT     |    |
|         |           |      |               | NUT, M5.56                   |    |
|         |           |      |               | NUT, M5.56                   |    |
|         |           |      |               | DRIVING-CONNECTING PLATE     |    |
|         |           |      |               | STUD SCREW, M4.37            |    |
|         |           |      |               | FELT                         |    |
|         |           |      |               | BOLT, SOCKET M6X20           |    |
|         |           |      |               | THREAD TRIMMER DRIVING ARM   |    |
|         |           |      |               | SCREW, PAN M4.37-40X5        |    |
|         |           |      |               | SET SCREW, SOCKET (CP) M5.95 |    |
|         |           |      |               | SET SCREW, SOCKET M5.95      |    |
|         |           |      |               | THREAD TRIMMER DRIVING SHAFT |    |
|         |           |      |               | SET COLLAR                   |    |
|         |           |      |               | SET SCREW, SOCKET (CP) M6.35 |    |
|         |           |      |               | CARRIAGE RETURN SPRING       |    |

From the library of: Diamond Needle Corp

S2. 下飾り糸切り関係 / Lower thread trimmer mechanism / Unterefadensabschneider /  
 Mécanisme de coupe-fils inférieur / Dispositivo de cortahilos inferior

B256-UT21,22,23,24  
 B257-UT21,23,42,44

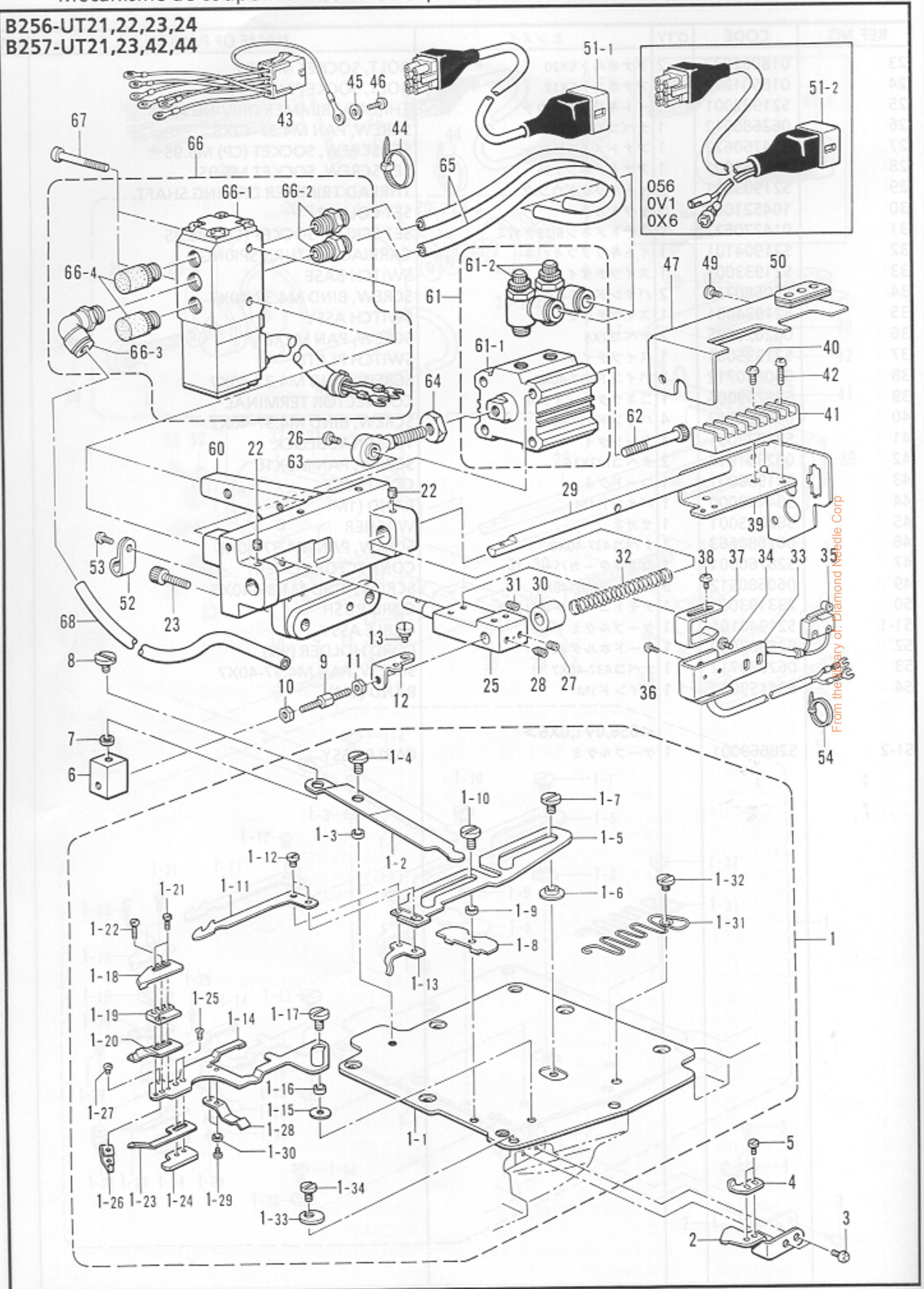

From the Library of: Diamond Needle Corp

S2. 下飾り糸切り関係 / Lower thread trimmer mechanism / Unterefadensabschneider /  
 Mécanisme de coupe-fils inférieur / Dispositivo de cortahilos inferior

| REF.NO. | CODE      | Q'TY | ヒンメイ                 | NAME OF PARTS                   | RM |
|---------|-----------|------|----------------------|---------------------------------|----|
|         | S21932001 |      | <B256-UT21,22,23,24> |                                 |    |
|         | 060680712 |      | <B257-UT21,23,42,44> |                                 |    |
| 1       | S28797101 | 1    | シタカザライトキリクミ          | LOWER THREAD TRIMMER ASSY       |    |
| 1-1     | S28490001 | 1    | ベッドウワカバーC            | BED UPPER COVER (C)             |    |
| 1-2     | S28644001 | 1    | シタメスクドウレバー           | LOWER KNIFE DRIVING LEVER       |    |
| 1-3     | S28645001 | 1    | カラー                  | COLLAR                          |    |
| 1-4     | S28646001 | 1    | シメネジ3.57             | SCREW, M3.57                    |    |
| 1-5     | S28647001 | 1    | シタメスドダイ              | LOWER KNIFE BASE                |    |
| 1-6     | S28648001 | 1    | ガイドチヨウセツタイ           | GUIDE ADJUST PLATE              |    |
| 1-7     | S28646001 | 1    | シメネジ3.57             | SCREW, M3.57                    |    |
| 1-8     | S28649000 | 1    | ドダイスライドイタA           | BASE SLIDE PLATE (A)            |    |
| 1-9     | S28645001 | 1    | カラー                  | COLLAR                          |    |
| 1-10    | S28646001 | 1    | シメネジ3.57             | SCREW, M3.57                    |    |
| 1-11    | S28650101 | 1    | シタメス                 | LOWER KNIFE                     |    |
| 1-12    | 106568003 | 2    | シメネジ3.57             | SCREW, M3.57                    |    |
| 1-13    | S28651001 | 1    | イトトリイタ               | THREAD TAKE-UP PLATE            |    |
| 1-14    | S28652001 | 1    | ウワメスドダイ              | UPPER KNIFE BASE                |    |
| 1-15    | S28653000 | 1    | ドダイスライドイタB           | BASE SLIDE PLATE (B)            |    |
| 1-16    | S28645001 | 1    | カラー                  | COLLAR                          |    |
| 1-17    | S28646001 | 1    | シメネジ3.57             | SCREW, M3.57                    |    |
| 1-18    | S28654001 | 1    | ウワメス                 | UPPER KNIFE                     |    |
| 1-19    | S28655001 | 1    | シタメスガイド              | LOWER KNIFE GUIDE               |    |
| 1-20    | S28656101 | 1    | イトツカミバネ              | THREAD CLAMP SPRING             |    |
| 1-21    | S28657001 | 2    | シメネジ2.38X6.5         | SCREW, M2.38X6.5                |    |
| 1-22    | S28658001 | 1    | シメネジ2.38X9.5         | SCREW, M2.38X9.5                |    |
| 1-23    | S28659101 | 1    | イトツカミチヨウセツバネ         | THREAD CLAMP ADJUST SPRING      |    |
| 1-24    | S28660001 | 1    | バネトリツケイタ             | SPRING SET PLATE                |    |
| 1-25    | S01694001 | 2    | サラネジ2.38X4           | SCREW, FLAT M2.38X4             |    |
| 1-26    | S28661001 | 1    | イトツカミチヨウセツタイ         | THREAD CLAMP ADJUST PLATE       |    |
| 1-27    | S01295001 | 1    | シメネジ2.38X3.5         | SCREW, M2.38X3.5                |    |
| 1-28    | S28662001 | 1    | ウワメスドダイササエバネ         | UPPER KNIFE BASE SUPPORT SPRING |    |
| 1-29    | 100105005 | 2    | シメネジ2.38             | SCREW, M2.38                    |    |
| 1-30    | 025630132 | 2    | ヒラザガネシヨウ2.38         | WASHER, PLAIN S 2.38            |    |
| 1-31    | S28663001 | 1    | ウワメスドダイオシバネ          | SPRING                          |    |
| 1-32    | 101671002 | 1    | シメネジ4.37             | SCREW, M4.37                    |    |
| 1-33    | S28318001 | 1    | ストツバ                 | STOPPER                         |    |
| 1-34    | 106629002 | 1    | シメネジ4.37             | SCREW, M4.37                    |    |
| 2       | S28665001 | 1    | ガイドイタA               | GUIDE PLATE (A)                 |    |
| 3       | 060680712 | 2    | バインド437-40X7         | SCREW, BIND M4.37-40X7          |    |
| 4       | S28666001 | 1    | ガイドイタB               | GUIDE PLATE (B)                 |    |
| 5       | 062670412 | 2    | ナベコ357-40X4          | SCREW, PAN M3.57-40X4           |    |
| 6       | S28667001 | 1    | クドウレンカンブロック          | DRIVING CONNECTING BLOCK        |    |
| 7       | S28645001 | 1    | カラー                  | COLLAR                          |    |
| 8       | S28646001 | 1    | シメネジ3.57             | SCREW, M3.57                    |    |
| 9       | S21906001 | 1    | クドウレンカンジク            | DRIVING CONNECTING SHAFT        |    |
| 10      | 110140001 | 1    | ナツト5.56              | NUT, M5.56                      |    |
| 11      | S21907001 | 1    | ナツト5.56              | NUT, M5.56                      |    |
| 12      | S28668001 | 1    | クドウレンカンイタ            | DRIVING CONNECTING PLATE        |    |
| 13      | 159908001 | 1    | ダンネジ4.37             | STUD SCREW, M4.37               |    |
| 22      | S09043000 | 2    | フェルト                 | FELT                            |    |
| 23      | 018062022 | 2    | アナボルト6X20            | BOLT, SOCKET M6X20              |    |
| 25      | S21902001 | 1    | イトキリクドウウデ            | THREAD TRIMMER DRIVING ARM      |    |
| 26      | 062680512 | 1    | ナベコ437-40X5          | SCREW, PAN M4.37-40X5           |    |
| 27      | 014760622 | 1    | アナトメネジ5.95           | SET SCREW, SOCKET (CP) M5.95    |    |
| 28      | 118853001 | 1    | アナトメネジ5.95           | SET SCREW, SOCKET M5.95         |    |
| 29      | S21903001 | 1    | イトキリクドウジク            | THREAD TRIMMER DRIVING SHAFT    |    |
| 30      | 104521002 | 1    | セットカラー               | SET COLLAR                      |    |
| 31      | 014770622 | 1    | アナトメネジ6.35クボミ        | SET SCREW, SOCKET (CP) M6.35    |    |
| 32      | S21904101 | 1    | イトキリフツキバネ            | CARRIAGE RETURN SPRING          |    |

From the library of: Diamond Needle Corp



S2. 下飾り糸切り関係 / Lower thread trimmer mechanism / Unterefadensabschneider / Mécanisme de coupe-fils inférieur / Dispositivo de cortahilos inferior

B256-UT21,22,23,24  
B257-UT21,23,42,44

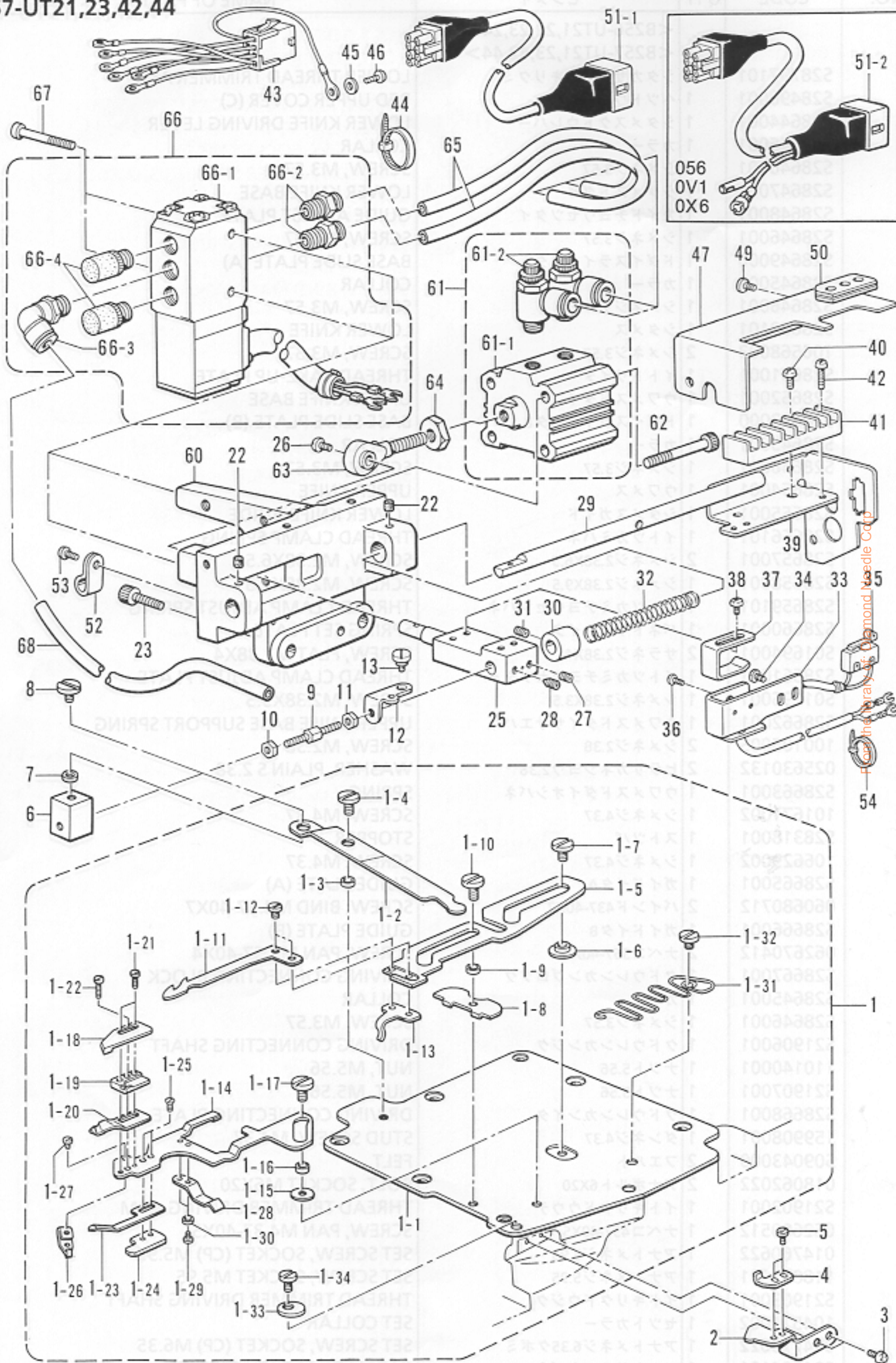

S2. 下飾り糸切り関係 / Lower thread trimmer mechanism / Unterefadensabschneider / Mécanisme de coupe-fils inférieur / Dispositivo de cortahilos inferior

| REF.NO. | CODE      | Q'TY | ヒンメイ                    | NAME OF PARTS                   | RM |
|---------|-----------|------|-------------------------|---------------------------------|----|
| 33      | S21933001 | 1    | スイッチダイ                  | SWITCH BASE                     |    |
| 34      | 060680712 | 2    | バインド437-40X7            | SCREW, BIND M4.37-40X7          |    |
| 35      | S21934001 | 1    | スイッチクミ                  | SWITCH ASSY                     |    |
| 36      | 062020805 | 2    | ナベコ2X8                  | SCREW, PAN M2X8                 |    |
| 37      | S21935001 | 1    | スイッチイタ                  | SWITCH PLATE                    |    |
| 38      | 060680712 | 2    | バインド437-40X7            | SCREW, BIND M4.37-40X7          |    |
| 39      | S28759001 | 1    | コネクタターミナル               | CONNECTOR TERMINAL              |    |
| 40      | 060680712 | 4    | バインド437-40X7            | SCREW, BIND M4.37-40X7          |    |
| 41      | S21937001 | 1    | タンシダイ                   | TERMINAL BLOCK                  |    |
| 42      | 062301616 | 2    | ナベコM3X16                | SCREW, PAN M3X16                |    |
| 43      | S21938001 | 1    | コードクミ                   | CORD ASSY                       |    |
| 44      | S04159000 | 1    | バンド1M                   | BAND (1M)                       |    |
| 45      | S02745001 | 1    | ザガネ                     | WASHER                          |    |
| 46      | 062680663 | 1    | ナベコ437-40X6             | SCREW, PAN M4.37-40X6           |    |
| 47      | S28760001 | 1    | コネクタカバー                 | CONNECTOR COVER                 |    |
| 49      | 060680512 | 3    | バインド437-40X5            | SCREW, BIND M4.37-40X5          |    |
| 50      | 233193001 | 1    | テモトコードブツシング             | CORD BUSH                       |    |
| 51-1    | S21940101 | 1    | ケーブルクミ                  | CABLE ASSY                      |    |
| 52      | S25907000 | 1    | コードホルダ#9                | CORD HOLDER (9N)                |    |
| 53      | 062680712 | 1    | ナベコ437-40X7             | SCREW, PAN M4.37-40X7           |    |
| 54      | S04159000 | 1    | バンド1M                   | BAND (1M)                       |    |
| 60      | S28678001 | 1    | イトキリシリンダードダイ            | THREAD TRIMMER CYLINDER BRACKET |    |
| 61      | S28670000 | 1    | エアシリンダクミ                | AIR CYLINDER ASSY               |    |
| 61-1    | S28671000 | 1    | エアシリンダ                  | AIR CYLINDER                    |    |
| 61-2    | S28599000 | 2    | スピードコントローラ              | SPEED CONTROLLER                |    |
| 62      | 415006002 | 4    | アナボルト5X40               | BOLT, SOCKET M5X40              |    |
| 63      | S21900001 | 1    | ロッドエンド                  | ROD END                         |    |
| 64      | 021080302 | 1    | ナツト3シユ8                 | NUT, 3 M8                       |    |
| 65      | S28674000 | 2    | エアチューブ (L=200)          | AIR TUBE (L=200)                |    |
| 66      | S28675000 | 1    | ソレノイドバルブクミ              | SOLENOID VALVE ASSY             |    |
| 66-1    | S28676000 | 1    | ソレノイドバルブ                | SOLENOID VALVE                  |    |
| 66-2    | S01522000 | 2    | ハーフユニオン                 | HALF UNION                      |    |
| 66-3    | S01542000 | 1    | エルボユニオン61               | ELBOW UNION 61                  |    |
| 66-4    | 159874000 | 2    | サイレンサー                  | SILENCER                        |    |
| 67      | 062303012 | 2    | ナベコM3X30                | SCREW, PAN M3X30                |    |
| 68      | S28677000 | 1    | エアチューブ (L=1000)         | AIR TUBE (L=1000)               |    |
| 51-2    | S28669001 | 1    | <056,0V1,0X6><br>ケーブルクミ | CABLE ASSY                      |    |

From the library of: Diamond Needle Corp

T. 上飾り糸切り関係 / Upper thread trimmer mechanism / Oberfadenabschneider /  
 Mécanisme de coupe-fils supérieur / Dispositivo de cortahilos superior

B257-UT32,34,42,44

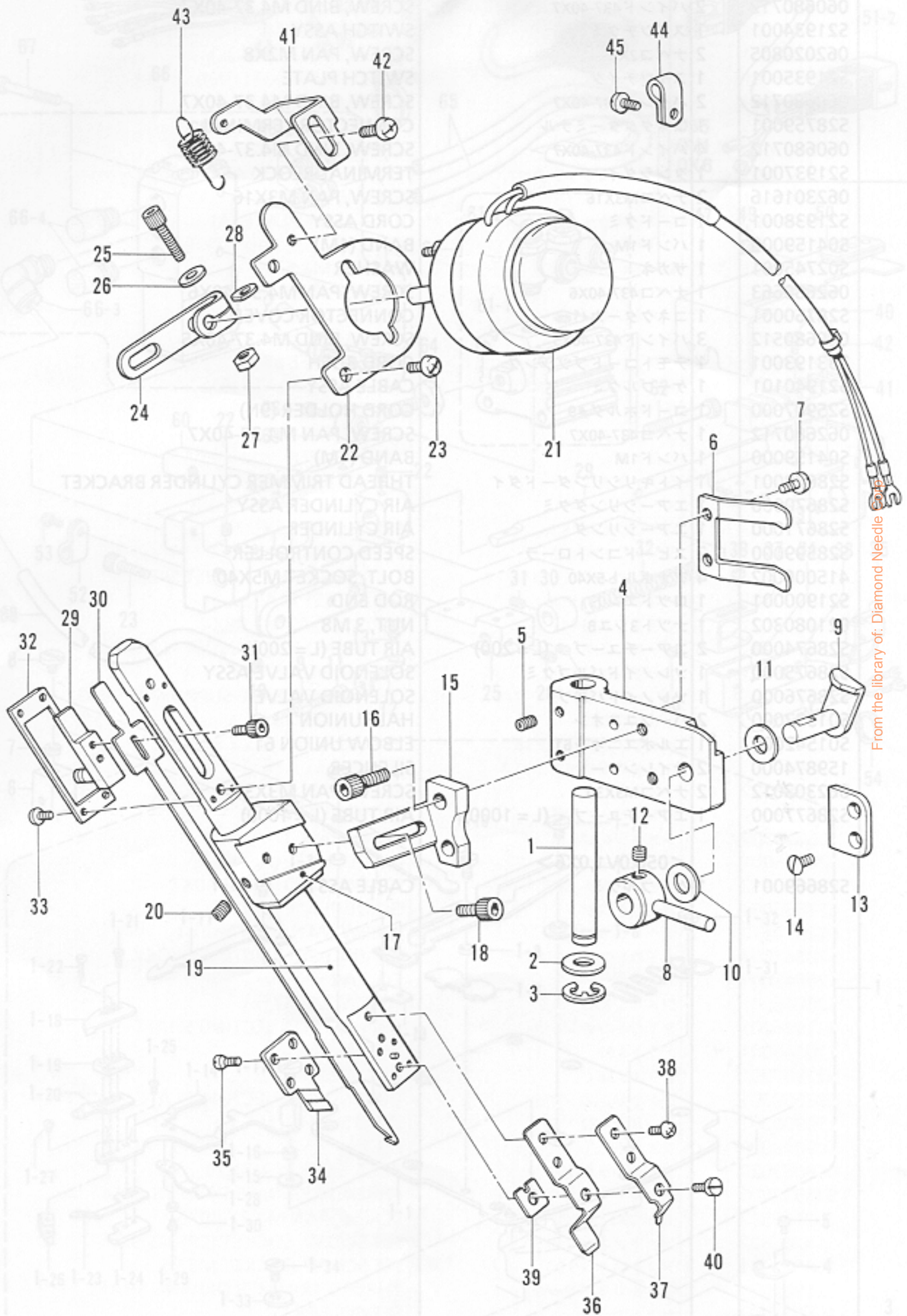

From the library of: Diamond Needle

T. 上飾り糸切り関係 / Upper thread trimmer mechanism / Oberfadenabschneider /  
 Mécanisme de coupe-fils supérieur / Dispositivo de cortahilos superior

| REF.NO. | CODE      | Q'TY | ヒンメイ                 | NAME OF PARTS                | RM |
|---------|-----------|------|----------------------|------------------------------|----|
|         |           |      | <B257-UT32,34,42,44> |                              |    |
| 1       | S21964001 | 1    | ドダイササエジク             | SUPPORT SHAFT                |    |
| 2       | S07350001 | 1    | ザガネ                  | WASHER                       |    |
| 3       | 048050342 | 1    | トメワE5                | RETAINING RING, E5           |    |
| 4       | S21965001 | 1    | イトキリドダイ              | THREAD TRIMMER BRACKET       |    |
| 5       | 014680422 | 2    | アナトメネジ4.37クボミ        | SET SCREW, SOCKET (CP) M4.37 |    |
| 6       | S21966001 | 1    | イトキリドダイバネ            | SPRING                       |    |
| 7       | 062680512 | 2    | ナベコ437-40X5          | SCREW, PAN M4.37-40X5        |    |
| 8       | S21967001 | 1    | イトキリドダイレバー           | THREAD TRIMMER BRACKET LEVER |    |
| 9       | S21968001 | 1    | ドダイレバージク             | LEVER SHAFT                  |    |
| 10      | 118735002 | 1    | ザガネ                  | WASHER                       |    |
| 11      | 109763002 | 1    | ザガネ                  | WASHER                       |    |
| 12      | 014680422 | 2    | アナトメネジ4.37クボミ        | SET SCREW, SOCKET (CP) M4.37 |    |
| 13      | S21969001 | 1    | イトキリドダイストツバ          | STOPPER                      |    |
| 14      | S01696001 | 2    | サラネジ3.57X6           | SCREW, FLAT M3.57X6          |    |
| 15      | S21970001 | 1    | イトキリトリツケタイ           | SET PLATE                    |    |
| 16      | 018501022 | 2    | アナボルト5X10            | BOLT, SOCKET M5X10           |    |
| 17      | S21971001 | 1    | メスガイドシジダイ            | KNIFE GUIDE BASE             |    |
| 18      | 018680822 | 2    | アナボルト4.37X8          | BOLT, SOCKET M4.37X8         |    |
| 19      | S21972001 | 1    | メスガイドクミ              | KNIFE GUIDE ASSY             |    |
| 20      | 014680422 | 2    | アナトメネジ4.37クボミ        | SET SCREW, SOCKET (CP) M4.37 |    |
| 21      | S21974001 | 1    | イトキリソレノイドクミ          | THREAD TRIMMER SOLENOID ASSY |    |
| 22      | S21976001 | 1    | ソレノイドダイ              | SOLENOID BRACKET             |    |
| 23      | 062680612 | 2    | ナベコ4.37-40X6         | SCREW, PAN M4.37-40X6        |    |
| 24      | S21977001 | 1    | イトキリクドウウデ            | THREAD TRIMMER DRIVING ARM   |    |
| 25      | 018401422 | 1    | アナボルト4X14            | BOLT, SOCKET M4X14           |    |
| 26      | 100645003 | 1    | ザガネ                  | WASHER                       |    |
| 27      | 021400102 | 1    | ナツト1シユ4              | NUT, 1 M4                    |    |
| 28      | S21978000 | 1    | カンザ                  | SPACER                       |    |
| 29      | S21979001 | 1    | メスクドウコマ              | KNIFE DRIVING BLOCK          |    |
| 30      | S21980001 | 1    | イドウメス                | MOVABLE KNIFE                |    |
| 31      | 018300622 | 2    | アナボルト3X6             | BOLT, SOCKET M3X6            |    |
| 32      | S21981001 | 1    | ガイドイタ                | GUIDE PLATE                  |    |
| 33      | 062630412 | 4    | ナベコ238-56X4          | SCREW, PAN M2.38-56X4        |    |
| 34      | S21982101 | 1    | コテイメス                | FIXED KNIFE                  |    |
| 35      | S21983001 | 4    | サラネジ2.38X5.5         | SCREW, FLAT M2.38X5.5        |    |
| 36      | S21984001 | 1    | イトツカミバネ              | THREAD HOLD SPRING           |    |
| 37      | S21985001 | 1    | イトツカミチヨウセツバネ         | THREAD CLAMP ADJUST SPRING   |    |
| 38      | 062660512 | 2    | ナベコネジ318-40X5        | SCREW, PAN M3.18-40X5        |    |
| 39      | S21986001 | 1    | スペーサ                 | SPACER                       |    |
| 40      | 102836004 | 1    | シメネジ3.18             | SCREW, M3.18                 |    |
| 41      | S21987001 | 1    | バネカケ                 | SPRING HOOK                  |    |
| 42      | 060680512 | 1    | バインド437-40X5         | SCREW, BIND M4.37-40X5       |    |
| 43      | S21988001 | 1    | モドシバネ                | RETURN SPRING                |    |
| 44      | 149547000 | 5    | コードオサエ#4             | CORD HOLDER (4N)             |    |
| 45      | 062680712 | 5    | ナベコ437-40X7          | SCREW, PAN M4.37-40X7        |    |

From the library of: Diamond Needle Corp

U. 電磁押工上げ関係 / Presser foot lifting solenoid set /  
 Solenoidsatz für die anhebung des stoffdrückerfußes /  
 Conjunto aéreo del levantador del pie / Conjunto solenoide del levantador

B256-UT13,14  
 B257-UT13,34

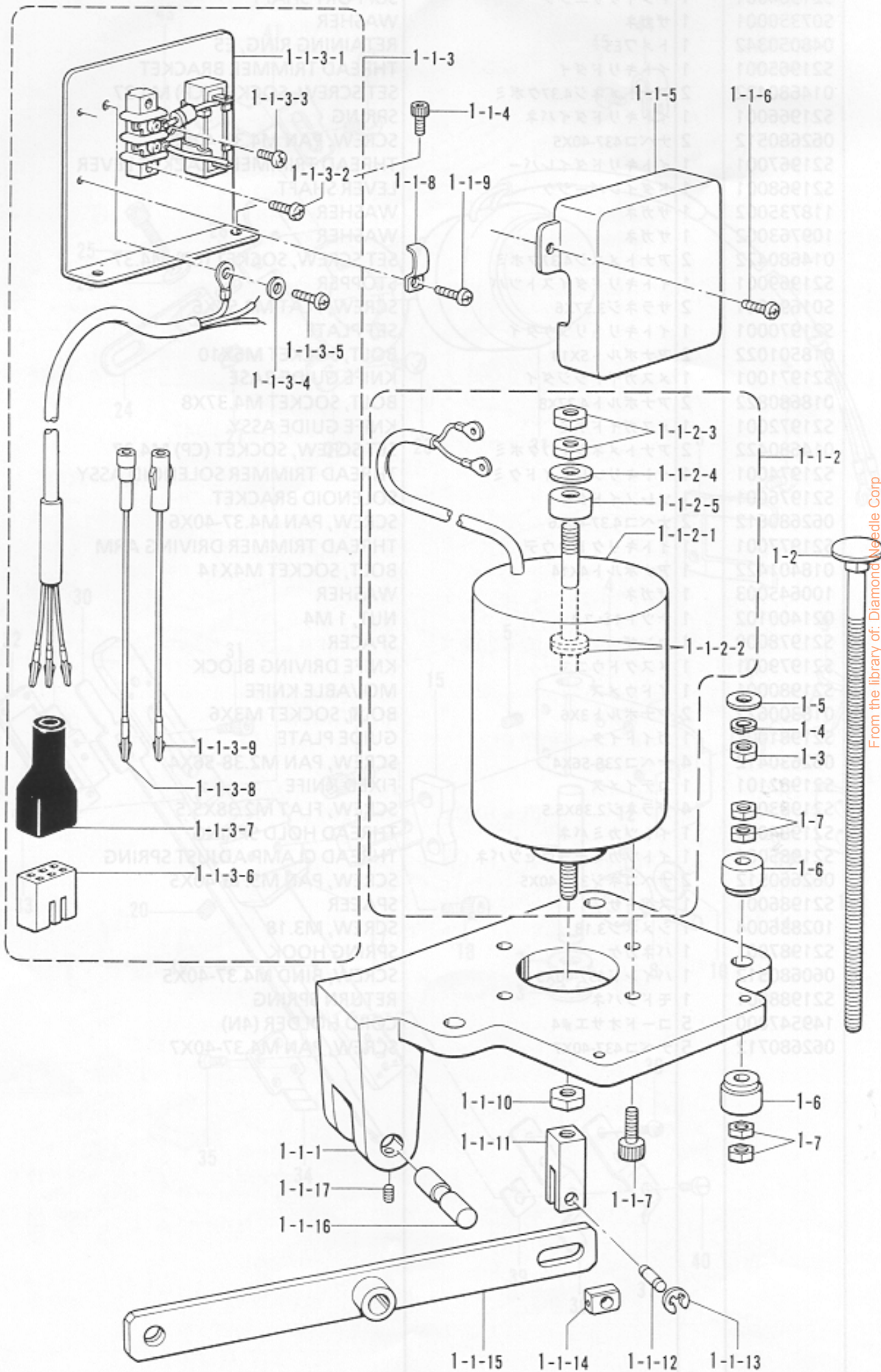

From the library of: Diamond Needle Corp

U. 電磁押工上げ関係 / Presser foot lifting solenoid set /  
 Solenoidsatz für die anhebung des stoffdrückerfußes /  
 Conjunto aéreo del levantador del pie / Conjunto solenoide del levantador

| REF.NO. | CODE      | Q'TY | ヒンメイ                             | NAME OF PARTS                         | RM |
|---------|-----------|------|----------------------------------|---------------------------------------|----|
|         |           |      | <B256-UT13,14><br><B257-UT13,34> |                                       |    |
| 1       | 183796201 | 1    | デンジオサエアゲセットB                     | SOLENOID PRESSER FOOT LIFTING SET (B) |    |
| 1-1     | S21946101 | 1    | デンジオサエアゲクミ                       | SOLENOID PRESSER FOOT LIFTING ASSY    |    |
| 1-1-1   | S21947001 | 1    | ソレノイドダイ                          | SOLENOID BRACKET                      |    |
| 1-1-2   | S21948101 | 1    | オサエアゲソレノイドクミ                     | PRESSER FOOT LIFTING SOLENOID ASSY    |    |
| 1-1-2-1 | S21949101 | 1    | オサエアゲソレノイド                       | PRESSER FOOT LIFTING SOLENOID         |    |
| 1-1-2-2 | S21899000 | 2    | ストツバゴム                           | RUBBER STOPPER                        |    |
| 1-1-2-3 | 021080302 | 2    | ナツト3シユ8                          | NUT, 3 M8                             |    |
| 1-1-2-4 | 025080232 | 1    | ヒラザガネチユウ8                        | WASHER, PLAIN M 8                     |    |
| 1-1-2-5 | S28821000 | 1    | カンシヨウゴム                          | CUSHION RUBBER                        |    |
| 1-1-3   | S21950009 | 1    | タンシダイベースクミ                       | TERMINAL BLOCK BASE ASSY              |    |
| 1-1-3-1 | S21951001 | 1    | タンシダイベース                         | TERMINAL BLOCK BASE                   |    |
| 1-1-3-2 | 062671012 | 2    | ナベコ357-40X10                     | SCREW, PAN M3.57-40X10                |    |
| 1-1-3-3 | 062670612 | 1    | ナベコ357-40X6                      | SCREW, PAN M3.57-40X6                 |    |
| 1-1-3-4 | S02745001 | 1    | ザガネ                              | WASHER                                |    |
| 1-1-3-5 | 062680663 | 1    | ナベコ437-40X6                      | SCREW, PAN M4.37-40X6                 |    |
| 1-1-3-6 | 143522000 | 1    | ナイロンコネクター                        | NYLON CONNECTOR                       |    |
| 1-1-3-7 | 220077001 | 1    | プラグカバー#14                        | PLUG COVER (#14)                      |    |
| 1-1-3-8 | S05981000 | 1    | Bコード100クミ2                       | B-CORD 100 ASSY 2                     |    |
| 1-1-3-9 | S05982000 | 1    | Wコード100クミ                        | W-CORD 100 ASSY                       |    |
| 1-1-4   | 018400832 | 2    | アナボルト4X8                         | BOLT, SOCKET M4X8                     |    |
| 1-1-5   | S02592009 | 1    | タンシダイカバー                         | TERMINAL BLOCK COVER                  |    |
| 1-1-6   | 062670612 | 2    | ナベコ357-40X6                      | SCREW, PAN M3.57-40X6                 |    |
| 1-1-7   | 018061631 | 4    | アナボルト6X16                        | BOLT, SOCKET M6X16                    |    |
| 1-1-8   | 142268001 | 1    | コードオサエL                          | CORD HOLDER (L)                       |    |
| 1-1-9   | 062670612 | 1    | ナベコ357-40X6                      | SCREW, PAN M3.57-40X6                 |    |
| 1-1-10  | 021080302 | 1    | ナツト3シユ8                          | NUT, 3 M8                             |    |
| 1-1-11  | S21953001 | 1    | ソレノイドツギテ                         | SOLENOID JOINT                        |    |
| 1-1-12  | S09637001 | 1    | ピン                               | PIN                                   |    |
| 1-1-13  | 048040342 | 2    | トメワE4                            | RETAINING RING, E4                    |    |
| 1-1-14  | 102630001 | 1    | ハリボウアンナイカクコマ                     | NEEDLE BAR GUIDE SLIDE BLOCK          |    |
| 1-1-15  | S21954001 | 1    | オサエアゲレバー                         | PRESSER BAR LIFTER LEVER              |    |
| 1-1-16  | S21955001 | 1    | オサエアゲレバージク                       | PRESSER BAR LIFTER LEVER SHAFT        |    |
| 1-1-17  | 014710522 | 2    | アナトメネジ4.76クボミ                    | SET SCREW, SOCKET (CP) M4.76          |    |
| 1-2     | S21952101 | 3    | カクネマルアタマボルト                      | BOLT                                  |    |
| 1-3     | 021080106 | 3    | ナツト1シユ8                          | NUT, 1 M8                             |    |
| 1-4     | 028080242 | 3    | バネザガネ2-8                         | WASHER, SPRING 2-8                    |    |
| 1-5     | 025080236 | 3    | ヒラザガネチユウ8                        | WASHER, PLAIN M 8                     |    |
| 1-6     | 146254001 | 6    | モータカンザ                           | COLLAR                                |    |
| 1-7     | 021080302 | 12   | ナツト3シユ8                          | NUT, 3 M8                             |    |

From the library of: Diamond Needle Corp

V. エアー押工上げ関係 / Pneumatic presser foot lifting mechanism / Pneumatische stoffdrückerfußanhebevorrichtung / Dispositif pneumatique de releveur de pied presseur / Levantador neumático del prensatelas

B256-UT23,24  
B257-UT23,44

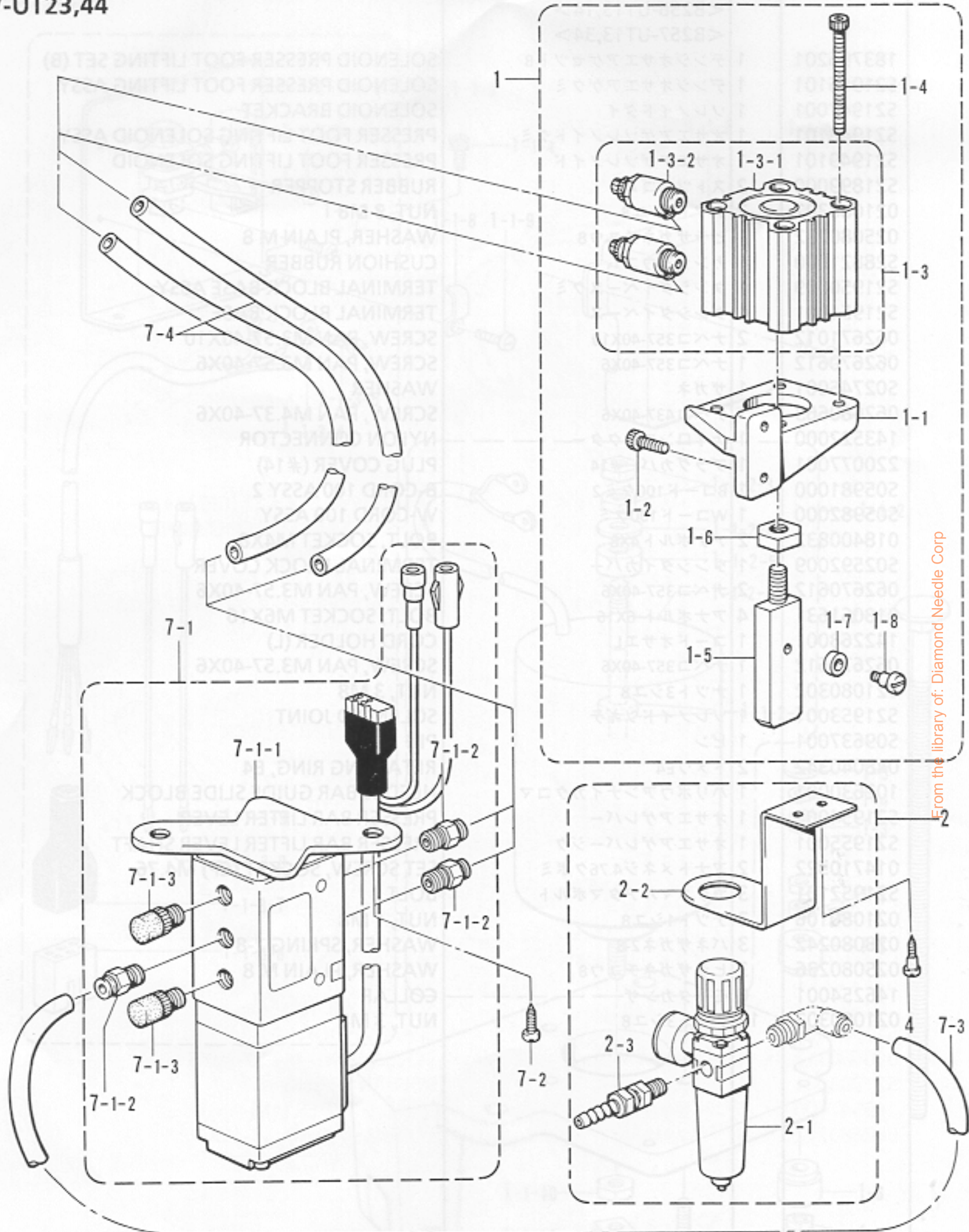

From the library of: Diamond Needle Corp

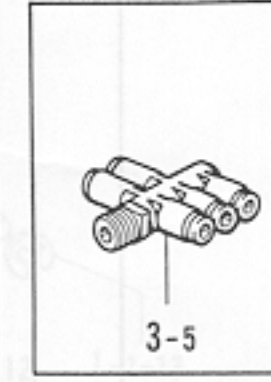
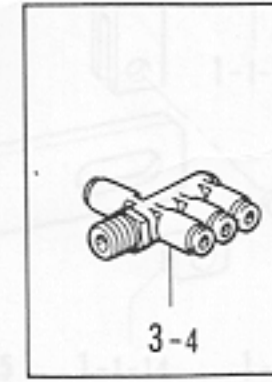
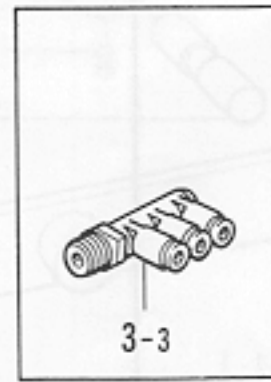
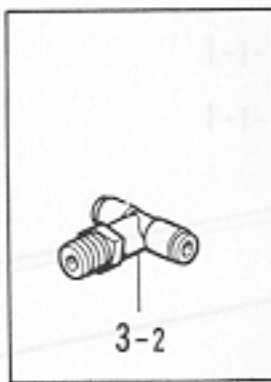
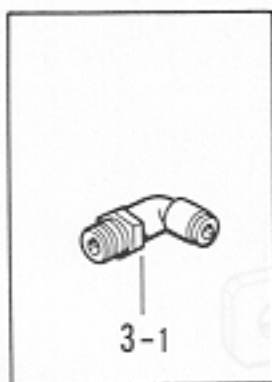

V. エアー押上げ関係 / Pneumatic presser foot lifting mechanism / Pneumatische stoffdrückerfußanhebevorrichtung / Dispositif pneumatique de releveur de pied presseur / Levantador neumático del prensatelas

| REF.NO. | CODE      | Q'TY | ヒンメイ                             | NAME OF PARTS                      | RM |
|---------|-----------|------|----------------------------------|------------------------------------|----|
|         |           |      | <B256-UT23,24><br><B257-UT23,44> | FABRIC TENSION ROLLER DEVICE ASSY  |    |
| 1       | S28681001 | 1    | オサエアゲシリンダクミ                      | PRESSER FOOT LIFTING SYLINDER ASSY |    |
| 1-1     | S28596001 | 1    | シリンダードダイ                         | CYLINDER BASE                      |    |
| 1-2     | 018061222 | 2    | アナボルト6X12                        | BOLT, SOCKET M6X12                 |    |
| 1-3     | S28597000 | 1    | エアーシリンダクミ                        | AIR CYLINDER ASSY                  |    |
| 1-3-1   | S28598000 | 1    | エアーシリンダ                          | AIR CYLINDER                       |    |
| 1-3-2   | S28599000 | 2    | スピードコントローラ                       | SPEED CONTROLLER                   |    |
| 1-4     | 018505022 | 4    | アナボルト5X50                        | BOLT, SOCKET M5X50                 |    |
| 1-5     | S28600001 | 1    | オサエサドウボウ                         | PRESSER DRIVING BAR                |    |
| 1-6     | 021080302 | 1    | ナット3シユ8                          | NUT, 3 M8                          |    |
| 1-7     | 110167001 | 1    | コロ                               | ROLLER                             |    |
| 1-8     | 110168001 | 1    | コロジク                             | ROLLER SHAFT                       |    |
| 2       | S28468001 | 1    | エアーユニットクミ                        | AIR UNIT ASSY                      |    |
| 2-1     | S21352001 | 1    | フィルターレギュレータ                      | FILTER REGULATOR                   |    |
| 2-2     | S21353001 | 1    | エアユニットトリツケイタ                     | AIR UNIT SET PLATE                 |    |
| 2-3     | 140678000 | 1    | ホースツギテ                           | AIR TUBE JOINT                     |    |
| 3-2     | S28469000 | 1    | チーズユニオン                          | T-UNION (2)                        |    |
| 4       | 101118001 | 2    | マルモクネジ4.5X20                     | WOOD SCREW, ROUND M4.5X20          |    |
| 7       | S28682001 | 1    | オサエアゲバルブセット                      | PRESSER FOOT LIFTING VALVE SET     |    |
| 7-1     | S28683001 | 1    | オサエアゲバルブクミ                       | PRESSER FOOT LIFTING VALVE ASSY    |    |
| 7-1-1   | S28680001 | 1    | ソレノイドバルブクミ                       | SOLENOID VALVE ASSY                |    |
| 7-1-2   | S01522000 | 3    | ハーフユニオン                          | HALF UNION                         |    |
| 7-1-3   | 159874000 | 2    | サイレンサー                           | SILENCER                           |    |
| 7-2     | 032422505 | 2    | +マルモクネジ4.1X25                    | WOOD SCREW, ROUND M4.1X25          |    |
| 7-3     | S28685000 | 1    | エアーチューブ (L=310)                  | AIR TUBE (L=310)                   |    |
| 7-4     | S28686000 | 2    | エアーチューブ (L=900)                  | AIR TUBE (L=900)                   |    |
|         |           |      | <オプションパーツ>                       | <OPTION PARTS>                     |    |
| 3-1     | S04896000 | 1    | エルボユニオン                          | ELBOW UNION (1)                    |    |
| 3-3     | S28470000 | 1    | トリプルバンジヨー                        | TRIPLE JOINT (3)                   |    |
| 3-4     | S28471000 | 1    | トリプルバンジヨー                        | TRIPLE JOINT (4)                   |    |
| 3-5     | S28472000 | 1    | トリプルバンジヨー                        | TRIPLE JOINT (5)                   |    |
|         |           |      | ワッシャL6                           | WASHER, PLAIN L6                   |    |
|         |           |      | アナボルト6X8                         | BOLT, SOCKET M6X8                  |    |
|         |           |      | ローラソウチクミ                         | LOWER ROLLER ASSY                  |    |
|         |           |      | ローラDダイ                           | ROLLER (D) BASE                    |    |
|         |           |      | マルモクネジ4.5X22                     | WOOD SCREW, ROUND M4.5X22          |    |
|         |           |      | ワッシャ                             | WASHER                             |    |
|         |           |      | ローラDササエイタ                        | ROLLER (D) SUPPORT PLATE           |    |
|         |           |      | クランプネジ                           | CLAMP SCREW                        |    |
|         |           |      | クランプレバーM8                        | CLAMP LEVER (M8)                   |    |
|         |           |      | ワッシャL6                           | WASHER, PLAIN L6                   |    |
|         |           |      | ローラクミ                            | ROLLER ASSY                        |    |
|         |           |      | ローラサポートシャフト                      | ROLLER SUPPORT SHAFT               |    |
|         |           |      | リテーニングリングE8                      | RETAINING RING, E8                 |    |
|         |           |      | ボールベアリング6000ZZ                   | BALL BEARING, 6000ZZ               |    |
|         |           |      | ワッシャL6                           | WASHER, PLAIN L6                   |    |
|         |           |      | アナボルト6X8                         | BOLT, SOCKET M6X8                  |    |



W1. 布張ローラ装置関係 / Fabric tension roller device set / Stoffspannrollervorrichtung /  
 Dispositif de rouleaux de tension du tissu / Dispositivo de rodillo tensor de tela

056  
 0V1  
 0X6

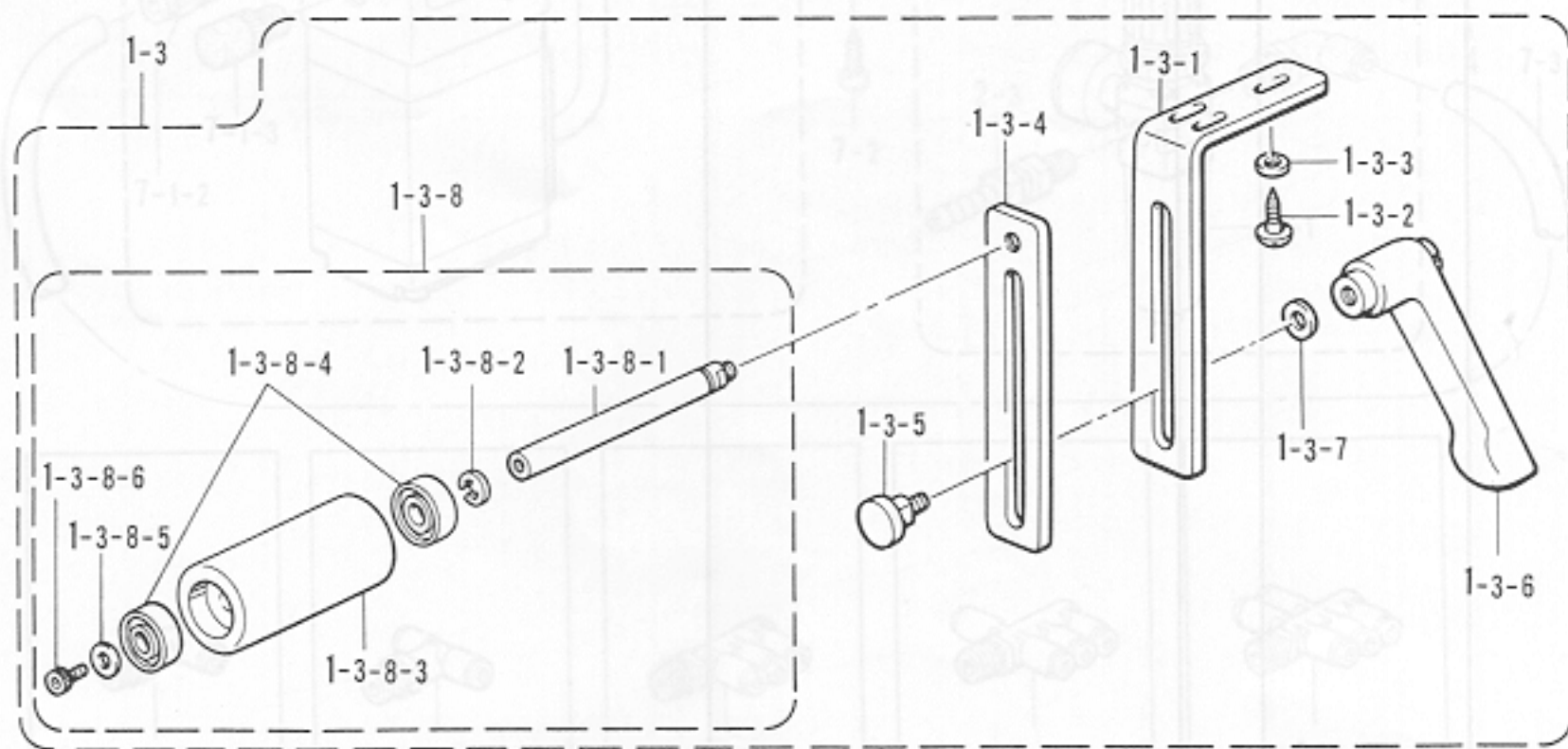
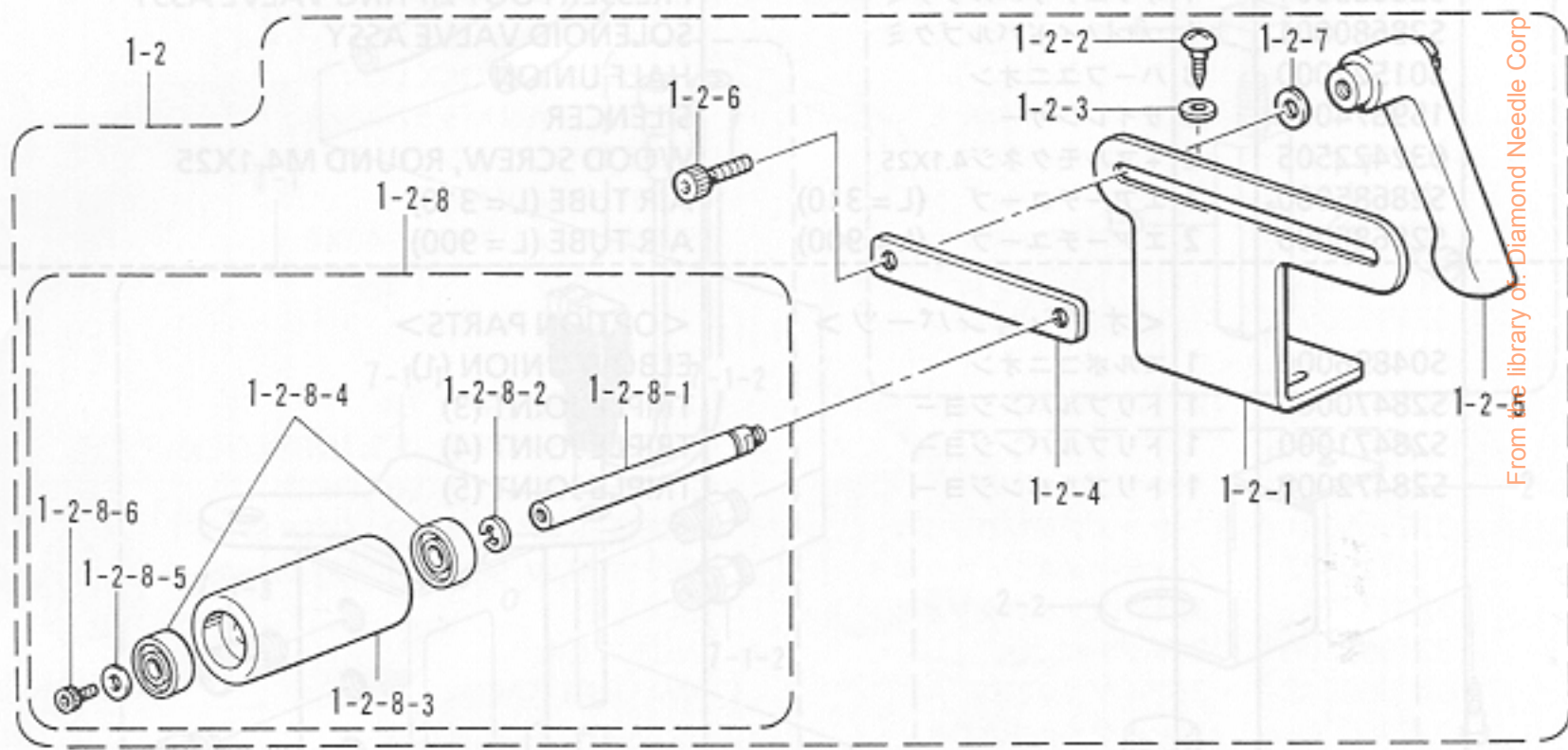
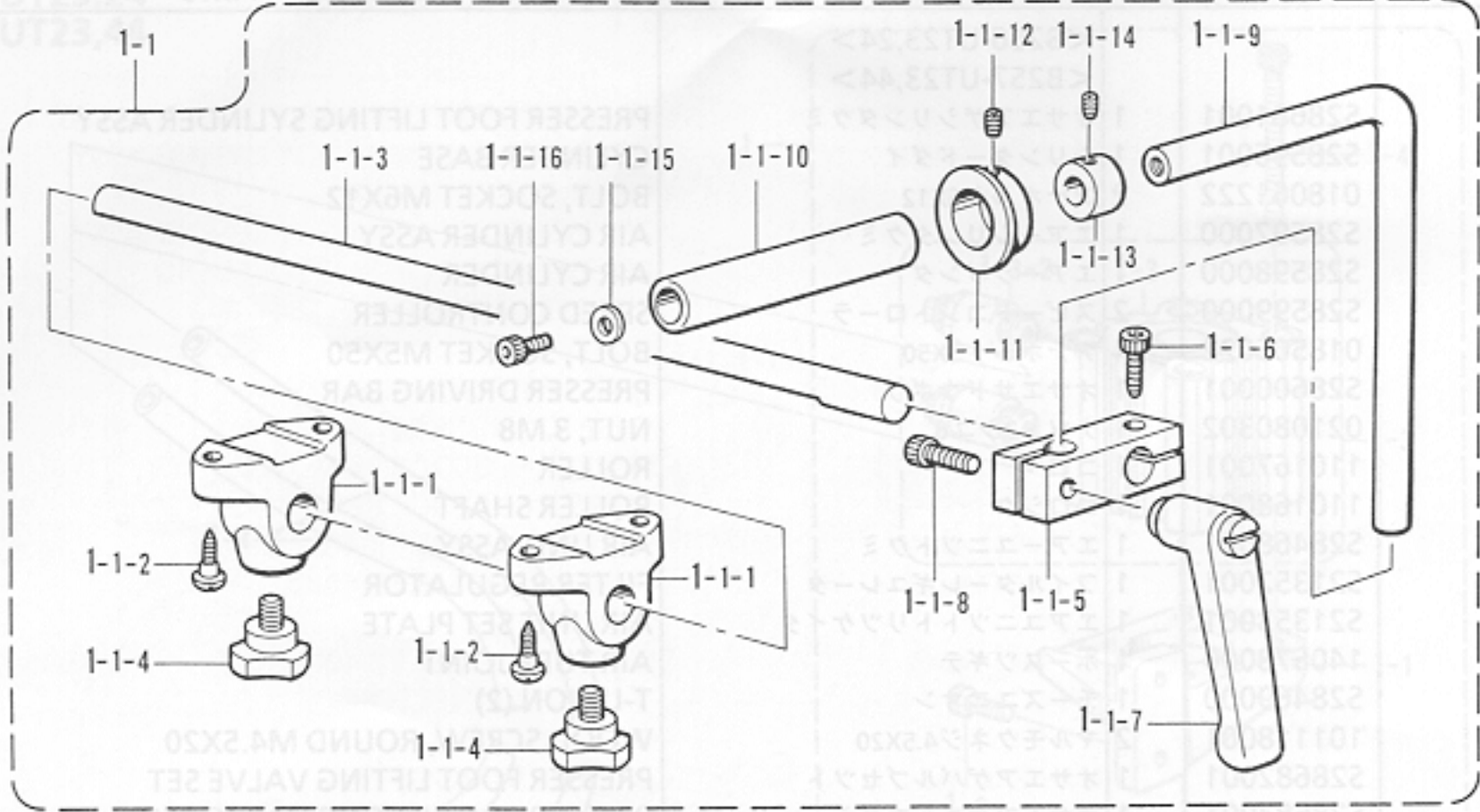

From the library of: Diamond Needle Corp

W1. 布張ローラ装置関係 / Fabric tension roller device set / Stoffspannrollervorrichtung / Dispositif de rouleaux de tension du tissu / Dispositivo de rodillo tensor de tela

| REF.NO. | CODE      | Q'TY | ヒンメイ                          | NAME OF PARTS                     | RM |
|---------|-----------|------|-------------------------------|-----------------------------------|----|
| 1       | S28687001 | 1    | <056,0V1,0X6><br>ヌノハリローラソウチクミ | FABRIC TENSION ROLLER DEVICE ASSY |    |
| 1-1     | S28688001 | 1    | マエローラソウチクミ                    | FRONT ROLLER ASSY                 |    |
| 1-1-1   | S28689001 | 2    | ローラFササエダイ                     | ROLLER (F) SUPPORT BRACKET        |    |
| 1-1-2   | 031452206 | 4    | マルモク45X22                     | WOOD SCREW, ROUND M4.5X22         |    |
| 1-1-3   | S28690001 | 1    | ローラゼンゴジク                      | ROLLER LONGITUDINAL SHAFT         |    |
| 1-1-4   | S28691000 | 2    | ノブボルトM10                      | KNOB BOLT M10                     |    |
| 1-1-5   | S28692001 | 1    | ローラツギテ                        | ROLLER JOINT                      |    |
| 1-1-6   | 018082022 | 1    | アナボルト8X20                     | BOLT, SOCKET M8X20                |    |
| 1-1-7   | S28693000 | 1    | クランプレバーM8                     | CLAMP LEVER (M8)                  |    |
| 1-1-8   | 018082522 | 1    | アナボルト8X25                     | BOLT, SOCKET M8X25                |    |
| 1-1-9   | S28694001 | 1    | ローラFササエジク                     | ROLLER (F) SUPPORT SHAFT          |    |
| 1-1-10  | S28695000 | 1    | ローラF                          | ROLLER (F)                        |    |
| 1-1-11  | S28696001 | 1    | ローラFカラー                       | ROLLER (F) COLLAR                 |    |
| 1-1-12  | 014680422 | 1    | アナトメネジ4.37クボミ                 | SET SCREW, SOCKET (CP) M4.37      |    |
| 1-1-13  | 153788001 | 1    | セットカラー                        | SET COLLAR                        |    |
| 1-1-14  | 014770622 | 2    | アナトメネジ6.35クボミ                 | SET SCREW, SOCKET (CP) M6.35      |    |
| 1-1-15  | 118735002 | 1    | ザガネ                           | WASHER                            |    |
| 1-1-16  | 018060822 | 1    | アナボルト6X8                      | BOLT, SOCKET M6X8                 |    |
| 1-2     | S28697001 | 1    | ウシロローラソウチクミ                   | REAR ROLLER ASSY                  |    |
| 1-2-1   | S28698001 | 1    | ローラBドダイ                       | ROLLER (B) BASE                   |    |
| 1-2-2   | 031452206 | 3    | マルモク45X22                     | WOOD SCREW, ROUND M4.5X22         |    |
| 1-2-3   | 146354001 | 3    | ザガネ                           | WASHER                            |    |
| 1-2-4   | S28699001 | 1    | ローラBササエイタ                     | ROLLER (B) SUPPORT PLATE          |    |
| 1-2-5   | S28693000 | 1    | クランプレバーM8                     | CLAMP LEVER (M8)                  |    |
| 1-2-6   | 018082022 | 1    | アナボルト8X20                     | BOLT, SOCKET M8X20                |    |
| 1-2-7   | 025080232 | 1    | ヒラザガネチユウ8                     | WASHER, PLAIN M 8                 |    |
| 1-2-8   | S28746001 | 1    | ローラクミ                         | ROLLER ASSY                       |    |
| 1-2-8-1 | S28700001 | 1    | ローラササエジク                      | ROLLER SUPPORT SHAFT              |    |
| 1-2-8-2 | 048080342 | 1    | トメワE8                         | RETAINING RING, E8                |    |
| 1-2-8-3 | S28701000 | 1    | ローラ                           | ROLLER                            |    |
| 1-2-8-4 | 076000800 | 2    | タマジクウケ6000ZZ                  | BALL BEARING, 6000ZZ              |    |
| 1-2-8-5 | 025060332 | 1    | ヒラザガネダイ6                      | WASHER, PLAIN L 6                 |    |
| 1-2-8-6 | 018060822 | 1    | アナボルト6X8                      | BOLT, SOCKET M6X8                 |    |
| 1-3     | S28705001 | 1    | シタローラソウチクミ                    | LOWER ROLLER ASSY                 |    |
| 1-3-1   | S28702001 | 1    | ローラDドダイ                       | ROLLER (D) BASE                   |    |
| 1-3-2   | 031452206 | 3    | マルモク45X22                     | WOOD SCREW, ROUND M4.5X22         |    |
| 1-3-3   | 146354001 | 3    | ザガネ                           | WASHER                            |    |
| 1-3-4   | S28703001 | 1    | ローラDササエイタ                     | ROLLER (D) SUPPORT PLATE          |    |
| 1-3-5   | S28704001 | 1    | クランプネジ                        | CLAMP SCREW                       |    |
| 1-3-6   | S28693000 | 1    | クランプレバーM8                     | CLAMP LEVER (M8)                  |    |
| 1-3-7   | 025080232 | 1    | ヒラザガネチユウ8                     | WASHER, PLAIN M 8                 |    |
| 1-3-8   | S28746001 | 1    | ローラクミ                         | ROLLER ASSY                       |    |
| 1-3-8-1 | S28700001 | 1    | ローラササエジク                      | ROLLER SUPPORT SHAFT              |    |
| 1-3-8-2 | 048080342 | 1    | トメワE8                         | RETAINING RING, E8                |    |
| 1-3-8-3 | S28701000 | 1    | ローラ                           | ROLLER                            |    |
| 1-3-8-4 | 076000800 | 2    | タマジクウケ6000ZZ                  | BALL BEARING, 6000ZZ              |    |
| 1-3-8-5 | 025060332 | 1    | ヒラザガネダイ6                      | WASHER, PLAIN L 6                 |    |
| 1-3-8-6 | 018060822 | 1    | アナボルト6X8                      | BOLT, SOCKET M6X8                 |    |

From the library of: Diamond Needle Corp

W2. 布張ローラ装置関係 / Fabric tension roller device set / Stoffspannrollervorrichtung /  
 Dispositif de rouleaux de tension du tissu / Dispositivo de rodillo tensor de tela

0W1

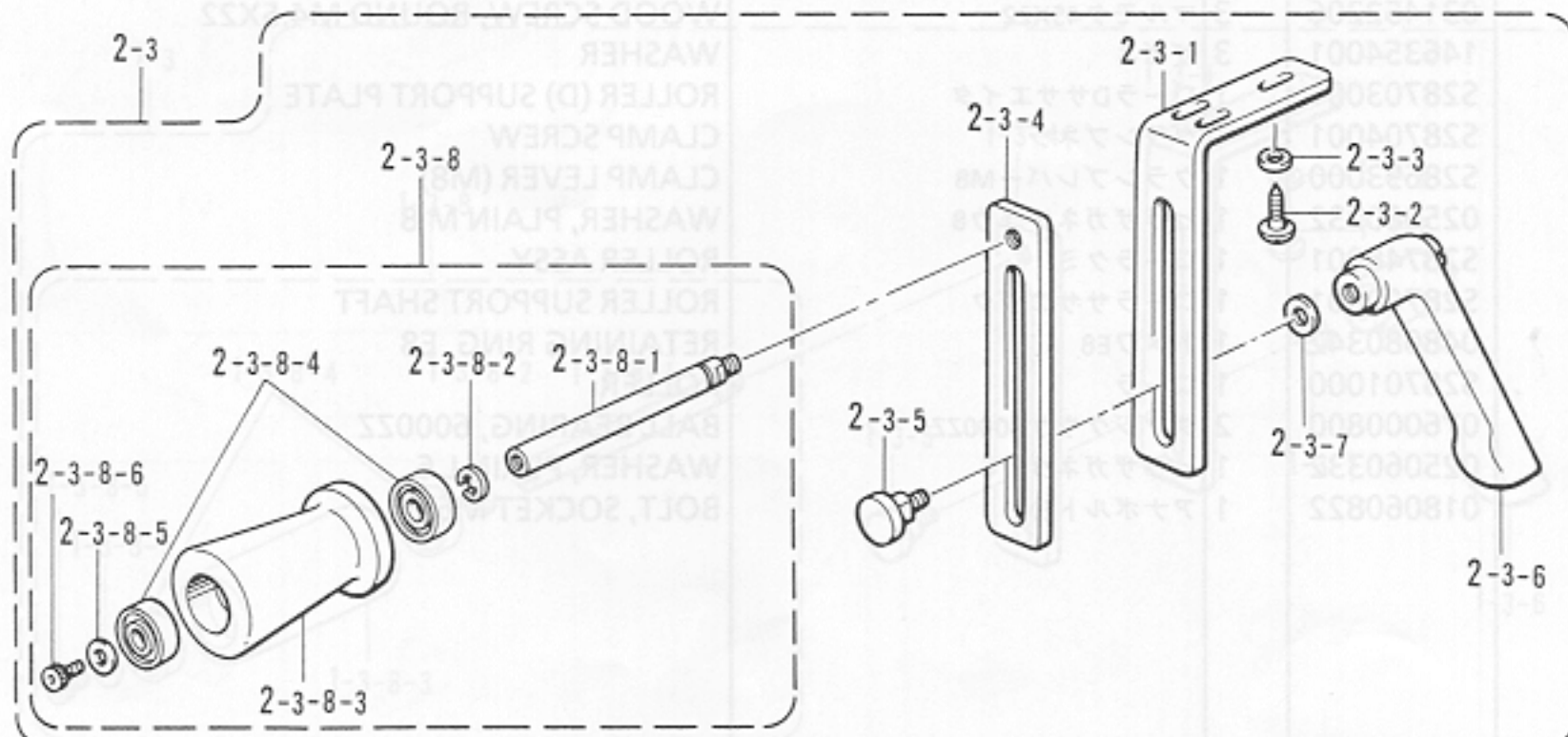
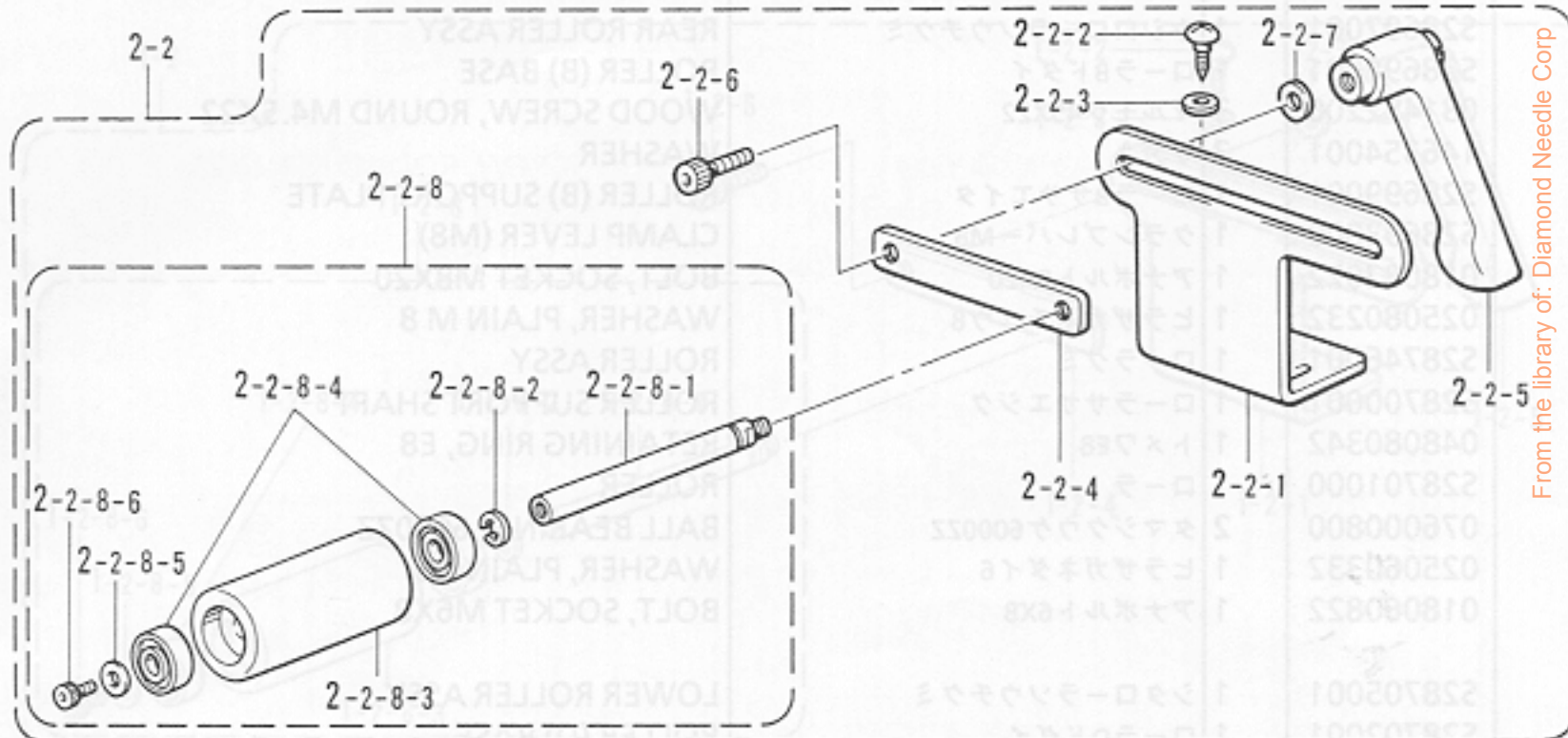
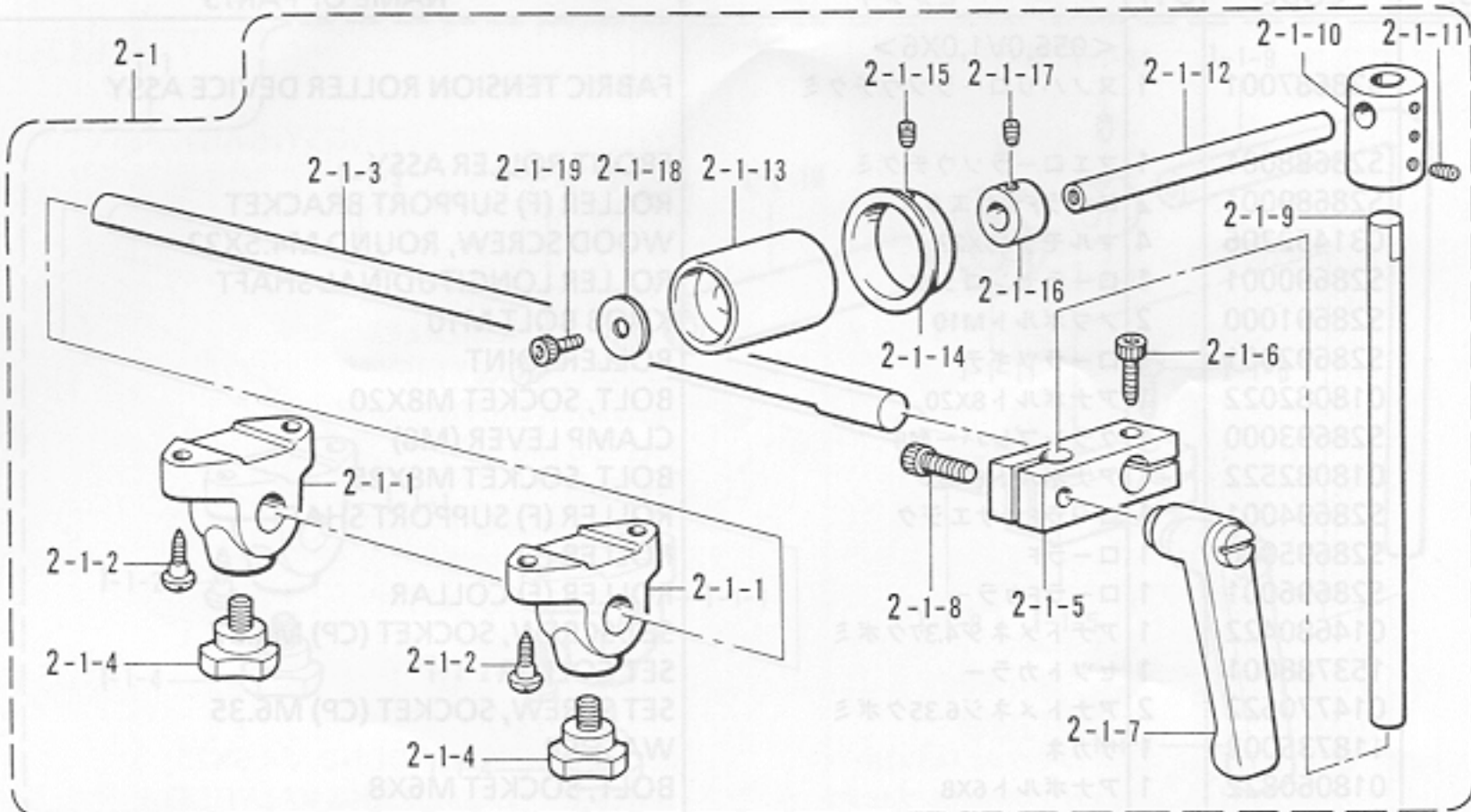

From the library of: Diamond Needle Corp

W2. 布張ローラ装置関係 / Fabric tension roller device set / Stoffspannrollervorrichtung /  
Dispositif de rouleaux de tension du tissu / Dispositivo de rodillo tensor de tela

| REF.NO. | CODE      | Q'TY | ヒンメイ                  | NAME OF PARTS                     | RM |
|---------|-----------|------|-----------------------|-----------------------------------|----|
| 2       | S28706001 | 1    | <0W1><br>ヌノハリローラソウチクミ | FABRIC TENSION ROLLER DEVICE ASSY |    |
| 2-1     | S28707001 | 1    | マエローラソウチクミ            | FRONT ROLLER ASSY                 |    |
| 2-1-1   | S28689001 | 2    | ローラFササエダイ             | ROLLER (F) SUPPORT BRACKET        |    |
| 2-1-2   | 031452206 | 4    | マルモク45X22             | WOOD SCREW, ROUND M4.5X22         |    |
| 2-1-3   | S28690001 | 1    | ローラゼンゴジク              | ROLLER LONGITUDINAL SHAFT         |    |
| 2-1-4   | S28691000 | 2    | ノブボルトM10              | KNOB BOLT M10                     |    |
| 2-1-5   | S28692001 | 1    | ローラツギテ                | ROLLER JOINT                      |    |
| 2-1-6   | 018082022 | 1    | アナボルト8X20             | BOLT, SOCKET M8X20                |    |
| 2-1-7   | S28693000 | 1    | クランプレバーM8             | CLAMP LEVER (M8)                  |    |
| 2-1-8   | 018082522 | 1    | アナボルト8X25             | BOLT, SOCKET M8X25                |    |
| 2-1-9   | S28708001 | 1    | ローラFタテジク              | ROLLER (F) VERTICAL SHAFT         |    |
| 2-1-10  | S28709001 | 1    | ローラFツギテ               | ROLLER (F) JOINT                  |    |
| 2-1-11  | 014770622 | 3    | アナトメネジ6.35クボミ         | SET SCREW, SOCKET (CP) M6.35      |    |
| 2-1-12  | S28710001 | 1    | ローラFジク                | ROLLER (F) SHAFT                  |    |
| 2-1-13  | S28711000 | 1    | ローラF                  | ROLLER (F)                        |    |
| 2-1-14  | S28712001 | 1    | ローラFカラー               | ROLLER (F) COLLAR                 |    |
| 2-1-15  | 014770622 | 1    | アナトメネジ6.35クボミ         | SET SCREW, SOCKET (CP) M6.35      |    |
| 2-1-16  | 153788001 | 1    | セットカラー                | SET COLLAR                        |    |
| 2-1-17  | 014770622 | 2    | アナトメネジ6.35クボミ         | SET SCREW, SOCKET (CP) M6.35      |    |
| 2-1-18  | 025060332 | 1    | ヒラザガネダイ6              | WASHER, PLAIN L 6                 |    |
| 2-1-19  | 018060822 | 1    | アナボルト6X8              | BOLT, SOCKET M6X8                 |    |
| 2-2     | S28697001 | 1    | ウシロローラソウチクミ           | REAR ROLLER ASSY                  |    |
| 2-2-1   | S28698001 | 1    | ローラBドダイ               | ROLLER (B) BASE                   |    |
| 2-2-2   | 031452206 | 3    | マルモク45X22             | WOOD SCREW, ROUND M4.5X22         |    |
| 2-2-3   | 146354001 | 3    | ザガネ                   | WASHER                            |    |
| 2-2-4   | S28699001 | 1    | ローラBササエイタ             | ROLLER (B) SUPPORT PLATE          |    |
| 2-2-5   | S28693000 | 1    | クランプレバーM8             | CLAMP LEVER (M8)                  |    |
| 2-2-6   | 018082022 | 1    | アナボルト8X20             | BOLT, SOCKET M8X20                |    |
| 2-2-7   | 025080232 | 1    | ヒラザガネチユウ8             | WASHER, PLAIN M 8                 |    |
| 2-2-8   | S28746001 | 1    | ローラクミ                 | ROLLER ASSY                       |    |
| 2-2-8-1 | S28700001 | 1    | ローラササエジク              | ROLLER SUPPORT SHAFT              |    |
| 2-2-8-2 | 048080342 | 1    | トメワE8                 | RETAINING RING, E8                |    |
| 2-2-8-3 | S28701000 | 1    | ローラ                   | ROLLER                            |    |
| 2-2-8-4 | 076000800 | 2    | タマジクウケ6000ZZ          | BALL BEARING, 6000ZZ              |    |
| 2-2-8-5 | 025060332 | 1    | ヒラザガネダイ6              | WASHER, PLAIN L 6                 |    |
| 2-2-8-6 | 018060822 | 1    | アナボルト6X8              | BOLT, SOCKET M6X8                 |    |
| 2-3     | S28714001 | 1    | シタローラソウチクミ            | LOWER ROLLER ASSY                 |    |
| 2-3-1   | S28702001 | 1    | ローラDドダイ               | ROLLER (D) BASE                   |    |
| 2-3-2   | 031452206 | 3    | マルモク45X22             | WOOD SCREW, ROUND M4.5X22         |    |
| 2-3-3   | 146354001 | 3    | ザガネ                   | WASHER                            |    |
| 2-3-4   | S28703001 | 1    | ローラDササエイタ             | ROLLER (D) SUPPORT PLATE          |    |
| 2-3-5   | S28704001 | 1    | クランプネジ                | CLAMP SCREW                       |    |
| 2-3-6   | S28693000 | 1    | クランプレバーM8             | CLAMP LEVER (M8)                  |    |
| 2-3-7   | 025080232 | 1    | ヒラザガネチユウ8             | WASHER, PLAIN M 8                 |    |
| 2-3-8   | S28747001 | 1    | ローラクミ                 | ROLLER ASSY                       |    |
| 2-3-8-1 | S28700001 | 1    | ローラササエジク              | ROLLER SUPPORT SHAFT              |    |
| 2-3-8-2 | 048080342 | 1    | トメワE8                 | RETAINING RING, E8                |    |
| 2-3-8-3 | S28716000 | 1    | ローラ                   | ROLLER                            |    |
| 2-3-8-4 | 076000800 | 2    | タマジクウケ6000ZZ          | BALL BEARING, 6000ZZ              |    |
| 2-3-8-5 | 025060332 | 1    | ヒラザガネダイ6              | WASHER, PLAIN L 6                 |    |
| 2-3-8-6 | 018060822 | 1    | アナボルト6X8              | BOLT, SOCKET M6X8                 |    |

From the library of: Diamond Needle Corp

X1. 付属アタッチメント / Attachment set / Anbausatz / Jeu d'accessoires / Juego de fijación

056 0X1  
 0V1 0X6  
 0W1

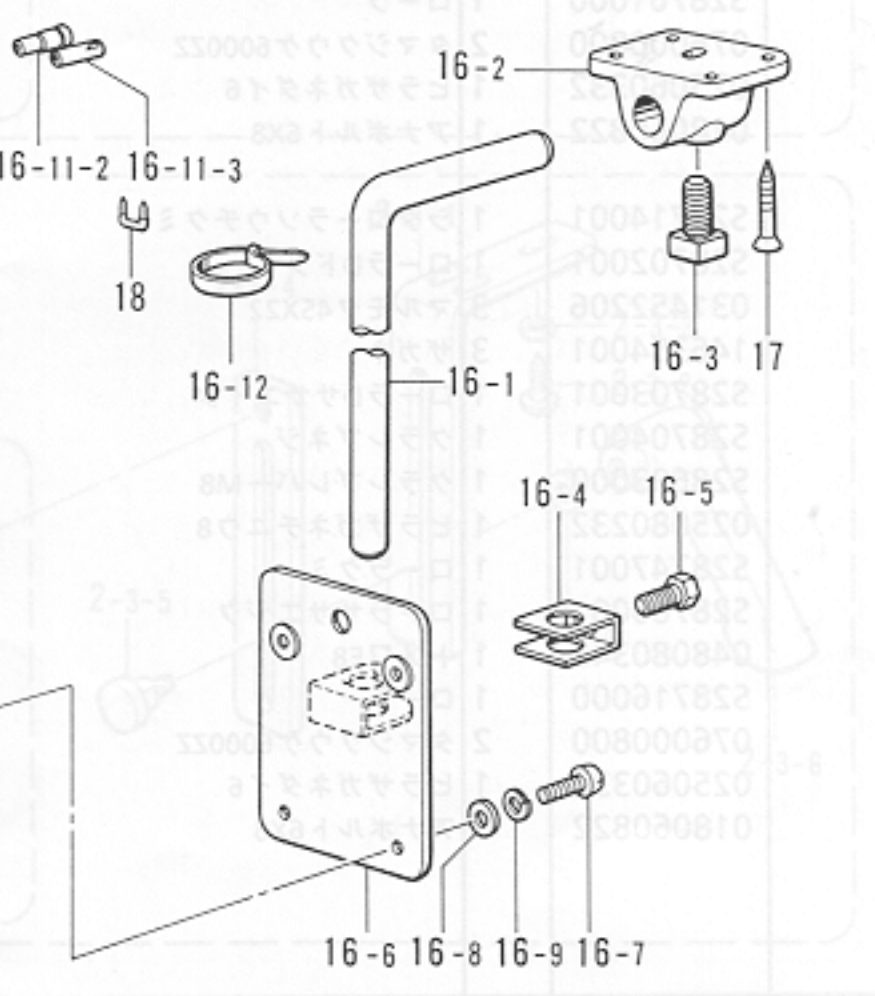
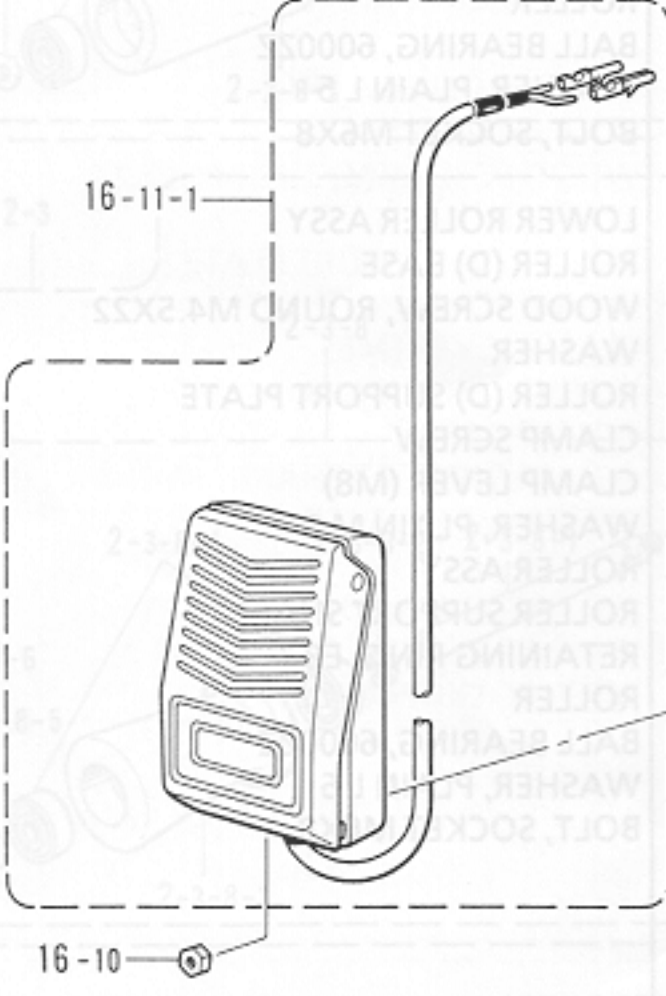
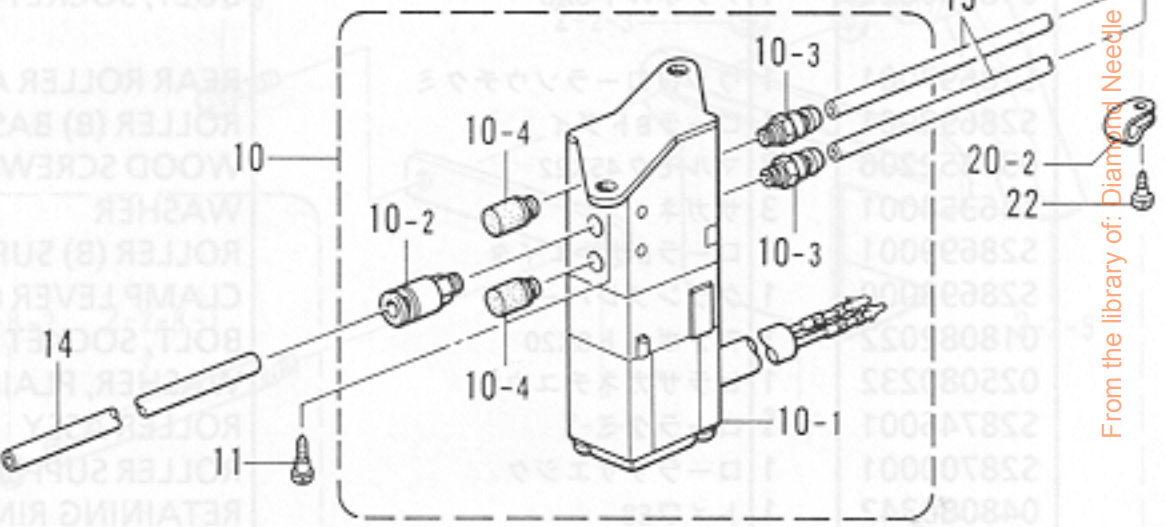
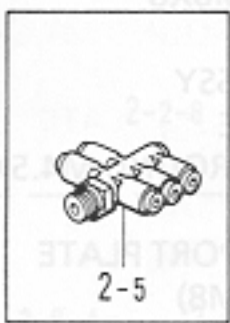
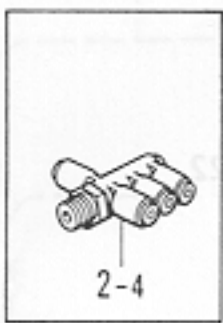
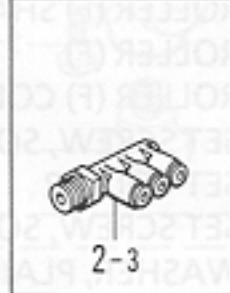
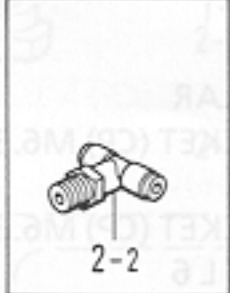
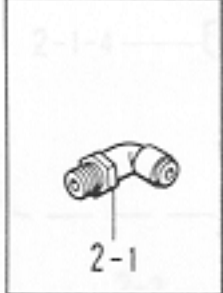
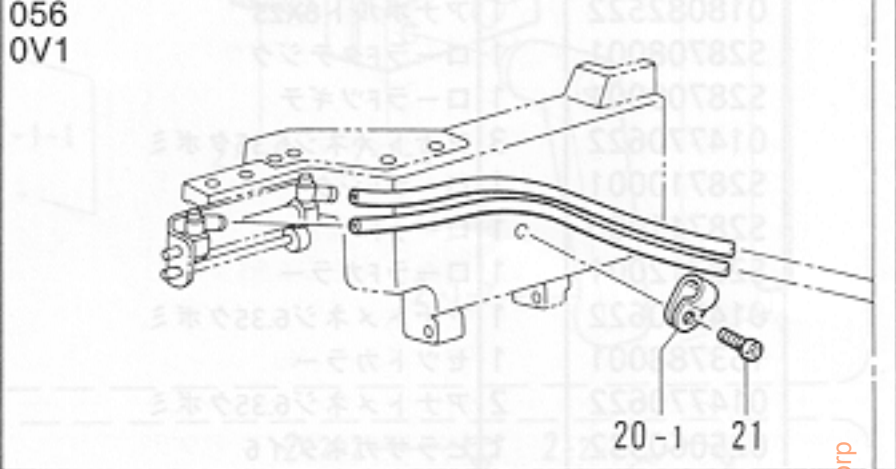
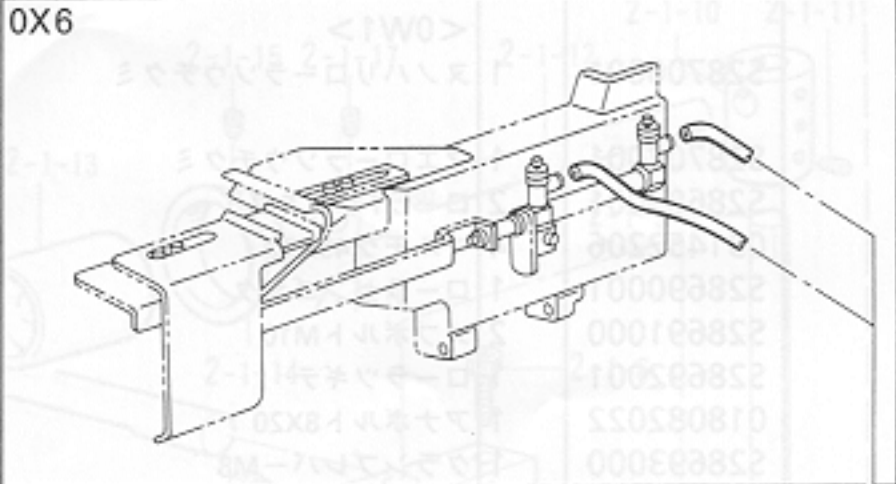
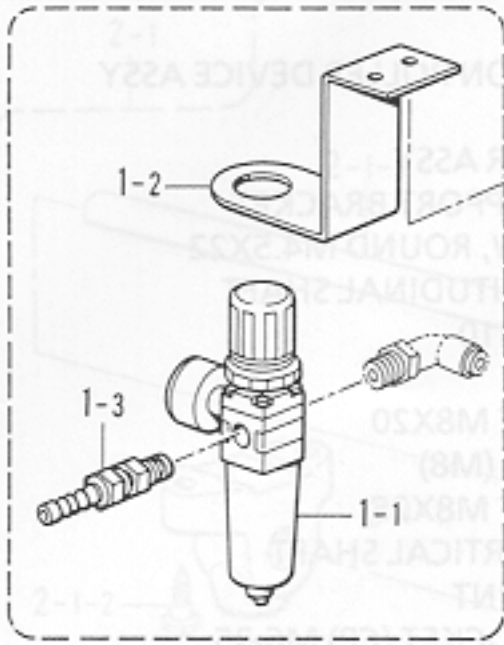

From the library of: Diamond Needle Corp

X1. 付属アタッチメント / Attachment set / Anbausatz / Jeu d'accessoires / Juego de fijación

| REF.NO.                            | CODE      | Q'TY | ヒンメイ              | NAME OF PARTS             | RM |
|------------------------------------|-----------|------|-------------------|---------------------------|----|
| <b>&lt;056,0V1,0W1,0X1,0X6&gt;</b> |           |      |                   |                           |    |
| 1                                  | S28468001 | 1    | エアーユニットクミ         | AIR UNIT ASSY             |    |
| 1-1                                | S21352001 | 1    | フィルターレギュレータ       | FILTER REGULATOR          |    |
| 1-2                                | S21353001 | 1    | エアーユニットトリツケイタ     | AIR UNIT SET PLATE        |    |
| 1-3                                | 140678000 | 1    | ホースツギテ            | AIR TUBE JOINT            |    |
| 2-1                                | S04896000 | 1    | エルボユニオン           | ELBOW UNION (1)           |    |
| 2-2                                | S28469000 | 1    | チーズユニオン           | T-UNION (2)               |    |
| 2-3                                | S28470000 | 1    | トリプルバンジヨー         | TRIPLE JOINT (3)          |    |
| 2-4                                | S28471000 | 1    | トリプルバンジヨー         | TRIPLE JOINT (4)          |    |
| 2-5                                | S28472000 | 1    | トリプルバンジヨー         | TRIPLE JOINT (5)          |    |
| 3                                  | 101118001 | 2    | マルモクネジ4.5X20      | WOOD SCREW, ROUND M4.5X20 |    |
| <b>&lt;056,0V1,0X6&gt;</b>         |           |      |                   |                           |    |
| 10                                 | S28726001 | 1    | ソレノイドバルブクミ        | SOLENOID VALVE ASSY       |    |
| 10-1                               | S28727000 | 1    | ソレノイドバルブ          | SOLENOID VALVE            |    |
| 10-2                               | S14145000 | 1    | ハーフユニオン06-M5      | HALF UNION 06-M5          |    |
| 10-3                               | S28742000 | 2    | ハーフユニオン           | HALF UNION                |    |
| 10-4                               | 153269001 | 2    | サイレンサー            | SILENCER                  |    |
| 11                                 | 031311302 | 2    | マルモクネジ3.1X13      | WOOD SCREW, ROUND M3.1X13 |    |
| 14                                 | S28685000 | 1    | エアーチューブ (L = 310) | AIR TUBE (L = 310)        |    |
| 15                                 | S28730000 | 2    | エアーチューブ (L = 930) | AIR TUBE (L = 930)        |    |
| 16                                 | S28720009 | 1    | ヒザスイッチクミ          | KNEE SWITCH ASSY          |    |
| 16-1                               | 142026003 | 1    | ヒザスイッチタテジク        | KNEE SWITCH SHAFT         |    |
| 16-2                               | 142027001 | 1    | ヒザスイッチタテジクウケ      | KNEE SWITCH SHAFT BRACKET |    |
| 16-3                               | 100463001 | 1    | 4カクボルト7.94        | BOLT, M7.94               |    |
| 16-4                               | 114967001 | 1    | ヒザアテストツバ          | KNEE LIFTER PLATE STOPPER |    |
| 16-5                               | 110087001 | 1    | ボルト5.95           | BOLT, M5.95               |    |
| 16-6                               | S07027001 | 1    | ヒザスイッチトリツケイタ      | KNEE LIFTER SWITCH PLATE  |    |
| 16-7                               | 062401006 | 4    | ナベコ4X10           | SCREW, PAN M4X10          |    |
| 16-8                               | 025040233 | 4    | ヒラザガネチユウ4         | WASHER, PLAIN M 4         |    |
| 16-9                               | 028040243 | 4    | バネザガネ2-4          | WASHER, SPRING 2-4        |    |
| 16-10                              | 021400164 | 4    | ナツト1シユ4           | NUT, 1 M4                 |    |
| 16-11                              | S28721009 | 1    | スイッチコードクミ         | SWITCH CORD ASSY          |    |
| 16-11-1                            | S28722009 | 1    | フットスイッチクミ         | FOOT SWITCH ASSY          |    |
| 16-11-2                            | 146046000 | 1    | ナイロンコネクター         | NYLON CONNECTOR           |    |
| 16-11-3                            | 146194000 | 1    | ナイロンコネクター         | NYLON CONNECTOR           |    |
| 16-12                              | 149799000 | 1    | タイラツプS            | BEAD BAND (S)             |    |
| 17                                 | 034422503 | 4    | +サラモクネジ4.1X25     | WOOD SCREW, FLAT M4.1X25  |    |
| 18                                 | 200190001 | 1    | ステツプル             | STAPLE                    |    |
| 20-2                               | S00480000 | 1    | コードホルダ#5          | CORD HOLDER (5N)          |    |
| 22                                 | 031311302 | 1    | マルモクネジ3.1X13      | WOOD SCREW, ROUND M3.1X13 |    |
| <b>&lt;056,0V1&gt;</b>             |           |      |                   |                           |    |
| 20-1                               | S00480000 | 1    | コードホルダ#5          | CORD HOLDER (5N)          |    |
| 21-2                               | 062680712 | 1    | ナベコ437-40X7       | SCREW, PAN M4.37-40X7     |    |
| <b>&lt;0X1,0X6&gt;</b>             |           |      |                   |                           |    |
| 56                                 | S28479000 | 1    | ホース               | HOSE ASSY                 |    |
| 56-1                               | S28480000 | 1    | ホース (L = 1500)    | HOSE (L = 1500)           |    |
| 56-2                               | S28481000 | 1    | ホース               | HOSE                      |    |
| 57                                 | S28745001 | 3    | サドル               | SADDLE                    |    |
| 58                                 | 031311302 | 6    | マルモクネジ3.1X13      | WOOD SCREW, ROUND M3.1X13 |    |

From the library of: Diamond Needle Corp

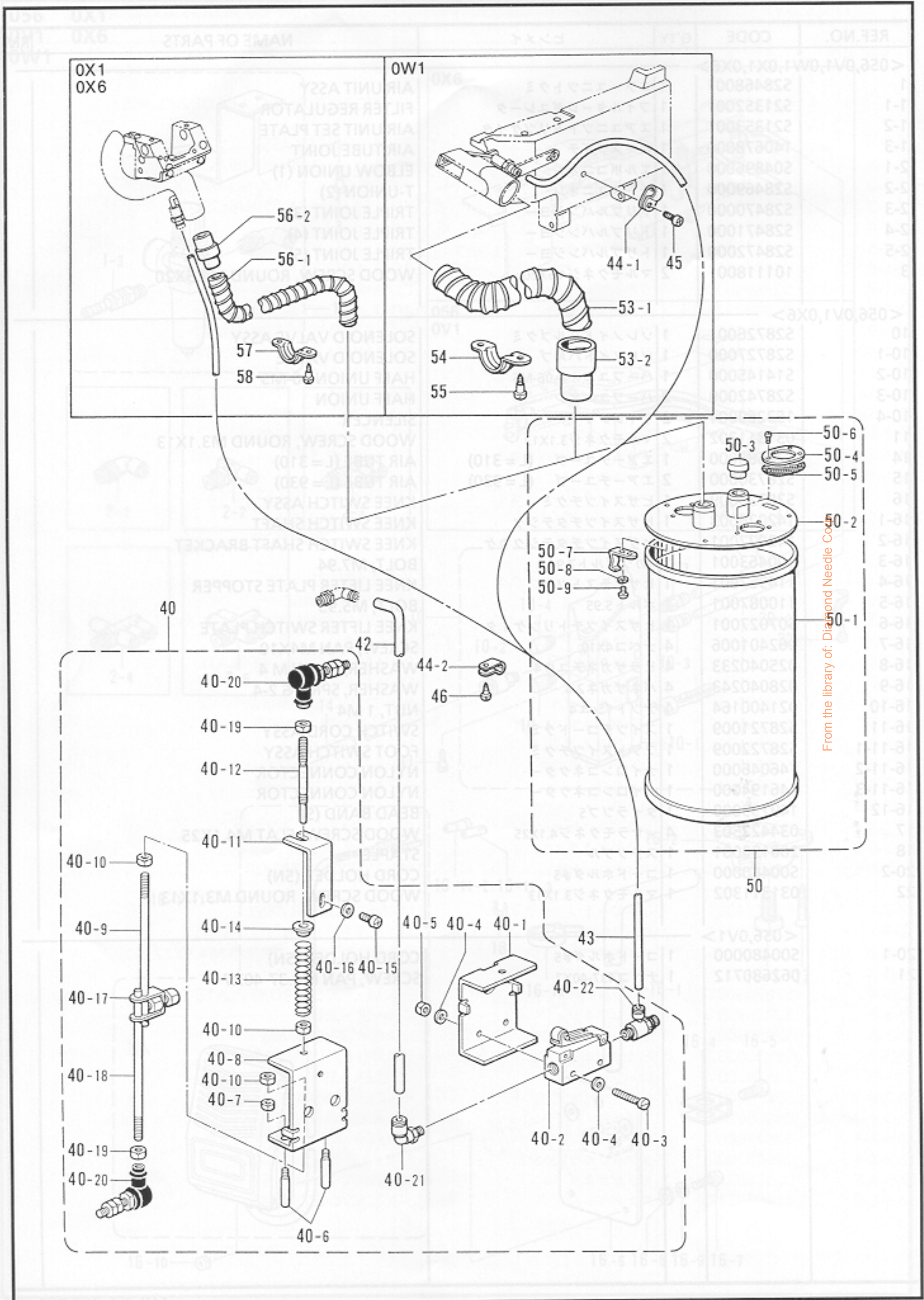

X2. 付属アタッチメント / Attachment set / Anbausatz / Jeu d'accessoires / Juego de fijación

| REF.NO.                    | CODE      | Q'TY | ヒンメイ                | NAME OF PARTS             | RM |
|----------------------------|-----------|------|---------------------|---------------------------|----|
| <b>&lt;0W1,0X1,0X6&gt;</b> |           |      |                     |                           |    |
| 40                         | S28473001 | 1    | レンカンクミ              | CONNECTING ROD ASSY       |    |
| 40-1                       | S21356001 | 1    | バルブトリツケイタ           | VALVE SET PLATE           |    |
| 40-2                       | S01561000 | 1    | メカバルブ               | MICRO VALVE               |    |
| 40-3                       | 007402516 | 2    | ヒラネジ4X25            | SCREW, FLAT M4X25         |    |
| 40-4                       | 025040236 | 4    | ヒラザガネチユウ4           | WASHER, PLAIN M4          |    |
| 40-5                       | 021400106 | 2    | ナツト1シユ4             | NUT, 1 M4                 |    |
| 40-6                       | S21357001 | 2    | ガイドピン               | PIN                       |    |
| 40-7                       | 021400206 | 4    | 2シユナツト4             | NUT, 2 M4                 |    |
| 40-8                       | S21358001 | 1    | バルブサドウイタ            | VALVE DIFFERENTIAL PLATE  |    |
| 40-9                       | 146695001 | 1    | レンカンナカ              | CONNECTING ROD INNER      |    |
| 40-10                      | 021060306 | 3    | 3シユナツト6             | NUT, 3 M6                 |    |
| 40-11                      | S21359001 | 1    | バネチヨウセツイタ           | SPRING ADJUST PLATE       |    |
| 40-12                      | S21360001 | 1    | レンカンU               | CONNECTING ROD (U)        |    |
| 40-13                      | S21361001 | 1    | オシバネA               | SPRING (A)                |    |
| 40-14                      | S21362000 | 1    | バネウケ                | SPRING HOLDER             |    |
| 40-15                      | 060400616 | 1    | バインドM4X6            | SCREW, BIND M4X6          |    |
| 40-16                      | 025040236 | 1    | ヒラザガネチユウ4           | WASHER, PLAIN M4          |    |
| 40-17                      | 181225001 | 1    | レンカンダキクミ            | CONNECTING ROD CLAMP ASSY |    |
| 40-18                      | 146695001 | 1    | レンカンナカ              | CONNECTING ROD INNER      |    |
| 40-19                      | 021060306 | 2    | 3シユナツト6             | NUT, 3 M6                 |    |
| 40-20                      | 119712001 | 2    | ジョイントクミ             | JOINT ASSY                |    |
| 40-21                      | S01542000 | 1    | エルボユニオン61           | ELBOW UNION 61            |    |
| 40-22                      | S23647000 | 1    | スピードコントローラ          | SPEED CONTROLLER          |    |
| 42                         | S28474000 | 1    | エアータブ (L = 480)     | AIR TUBE (L = 480)        |    |
| 43                         | S08138000 | 1    | エアータブS-A (L = 1030) | AIR TUBE S-A (L = 1030)   |    |
| 44-2                       | S10243000 | 1    | ナイロンランプNK-3N        | CORD HOLDER (NK-3N)       |    |
| 46                         | 031311302 | 1    | マルモクネジ3.1X13        | WOOD SCREW, ROUND M3.1X13 |    |
| 50                         | 147246101 | 1    | フィルタボックスクミ          | FILTER BOX ASSY           |    |
| 50-1                       | 147247009 | 1    | フィルタボックス            | FILTER BOX                |    |
| 50-2                       | 147248009 | 1    | フィルタボックスフタクミ        | FILTER BOX COVER ASSY     |    |
| 50-3                       | 147251009 | 1    | メクラセン               | OIL CAP                   |    |
| 50-4                       | 144625009 | 2    | ロカモウオサエ             | FILTER FLANGE             |    |
| 50-5                       | 147252000 | 2    | フィルタ                | FILTER                    |    |
| 50-6                       | 060670512 | 6    | バインド357-40X5        | SCREW, BIND M3.57-40X5    |    |
| 50-7                       | 111032001 | 3    | メンイタトメイタバネL         | STOPPER PLATE SPRING (L)  |    |
| 50-8                       | 105248003 | 3    | ザガネ                 | WASHER                    |    |
| 50-9                       | S01297001 | 3    | シメネジ3.57X3.5        | SCREW, M3.57X3.5          |    |
| <b>&lt;0W1&gt;</b>         |           |      |                     |                           |    |
| 44-1                       | S10243000 | 1    | ナイロンランプNK-3N        | CORD HOLDER (NK-3N)       |    |
| 45                         | 062680712 | 1    | ナベコ437-40X7         | SCREW, PAN M4.37-40X7     |    |
| 53                         | S28476000 | 1    | ホースクミ               | HOSE ASSY                 |    |
| 53-1                       | S28477000 | 1    | ホース (L = 1500)      | HOSE (L = 1500)           |    |
| 53-2                       | S28478000 | 1    | カフス                 | CUFFS                     |    |
| 54                         | 143359001 | 3    | サドル                 | SADDLE                    |    |
| 55                         | 101118001 | 6    | マルモクネジ4.5X20        | WOOD SCREW, ROUND M4.5X20 |    |
| <b>&lt;0X1,0X6&gt;</b>     |           |      |                     |                           |    |
| 56                         | S28479000 | 1    | ホースクミ               | HOSE ASSY                 |    |
| 56-1                       | S28480000 | 1    | ホース (L = 1500)      | HOSE (L = 1500)           |    |
| 56-2                       | S28481000 | 1    | カフス                 | CUFFS                     |    |
| 57                         | S28745001 | 3    | サドルバンド              | SADDLE BAND               |    |
| 58                         | 031311302 | 6    | マルモクネジ3.1X13        | WOOD SCREW, ROUND M3.1X13 |    |

From the library of: Diamond Needle Corp



<オプションパーツ / OPTION PARTS>

<右メス用ヒザ上げレバー装置 / Knee lifer device for right knife>

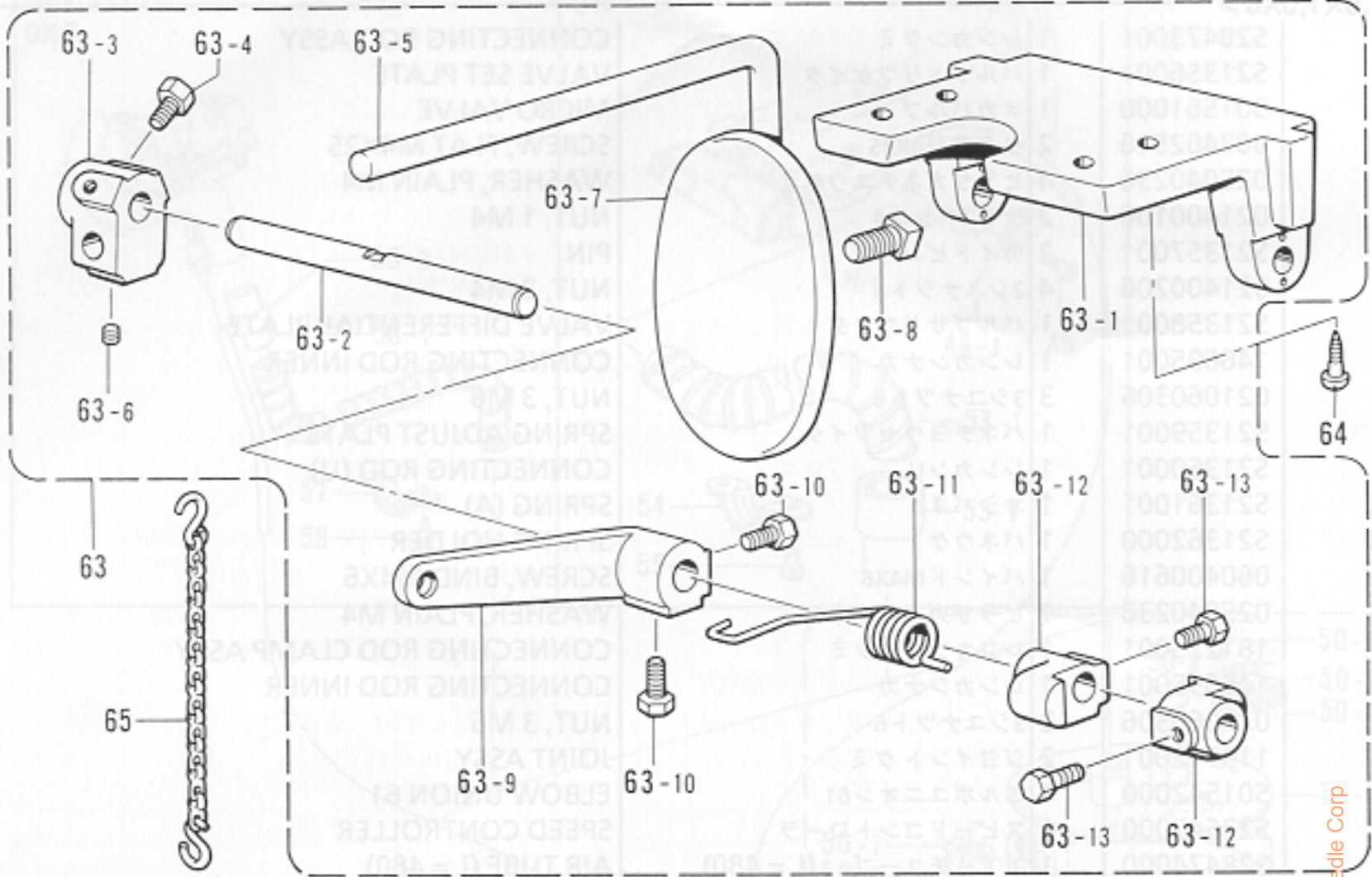

<コンデンスステッチ装置 / Condense stitch device>

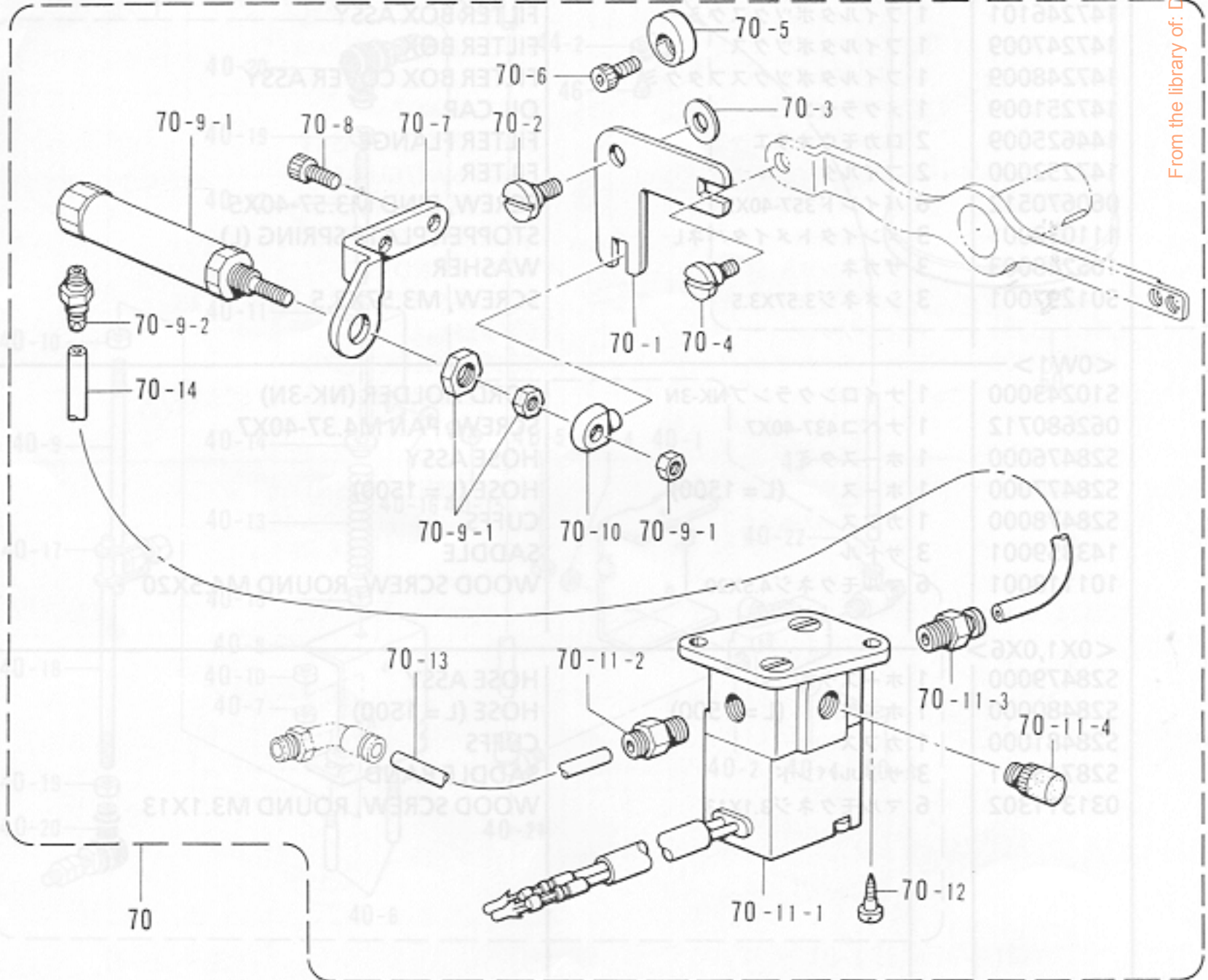

From the library of: Diamond Needle Corp

X3. 付属アタッチメント / Attachment set / Anbausatz / Jeu d'accessoires / Juego de fijación

| REF.NO. | CODE      | Q'TY | ヒンメイ                         | NAME OF PARTS                                | RM |
|---------|-----------|------|------------------------------|--|----|
| 63      | 155196309 | 1    | <オプションパーツ><br>サドウチヨウセツソウチクミ  | <OPTION PARTS><br>KNEE LIFTER DEVICE ASSY    |    |
| 63-1    | 155197101 | 1    | ヒザアテヨコジクウケ                   | KNEE LIFTER SHAFT BRACKET                    |    |
| 63-2    | 155198101 | 1    | ヨコジク                         | KNEE LIFTER SHAFT                            |    |
| 63-3    | 155199101 | 1    | ヒザアテツギテ                      | KNEE LIFTER BRACKET                          |    |
| 63-4    | 017781012 | 2    | ボルト6.35X10                   | BOLT, M6.35X10                               |    |
| 63-5    | 148797001 | 1    | ヒザアゲタテジクS                    | KNEE LIFTER BAR (S)                          |    |
| 63-6    | 014780622 | 1    | アナトメネジ6.35クボミ                | SET SCREW, SOCKET (CP) M6.35                 |    |
| 63-7    | 148798009 | 1    | ヒザアテL                        | KNEE LIFTER PLATE (L)                        |    |
| 63-8    | 100463001 | 1    | 4カクボルト7.94                   | BOLT, M7.94                                  |    |
| 63-9    | 155201101 | 1    | ヒザアテレバー                      | KNEE LIFTER LEVER                            |    |
| 63-10   | 017781012 | 2    | ボルト6.35X10                   | BOLT, M6.35X10                               |    |
| 63-11   | 155202001 | 1    | ヒザアテレバーバネ                    | SPRING                                       |    |
| 63-12   | S21378001 | 2    | ヨコジクトメグ                      | COLLAR                                       |    |
| 63-13   | 017781012 | 4    | ボルト6.35X10                   | BOLT, M6.35X10                               |    |
| 64      | 032422505 | 4    | +マルモクネジ4.1X25                | WOOD SCREW, ROUND M4.1X25                    |    |
| 65      | S28357001 | 1    | クサリクミ                        | CHAIN ASSY                                   |    |
| 70      | S28731001 | 1    | <オプションパーツ><br>コンデンスステッチソウチクミ | <OPTION PARTS><br>CONDENSE STITCH DEVICE SET |    |
| 70-1    | S28732001 | 1    | コンデンスステッチレバー                 | CONDENSE STITCH LEVER                        |    |
| 70-2    | 145480101 | 1    | ダンネジ6.35                     | STUD SCREW, M6.35                            |    |
| 70-3    | 151439002 | 1    | ザガネ                          | WASHER                                       |    |
| 70-4    | 115559002 | 1    | ダンネジ4.76                     | STUD SCREW, M4.76                            |    |
| 70-5    | S28733001 | 1    | レバーストツパ                      | LEVER STOPPER                                |    |
| 70-6    | 018680822 | 1    | アナボルト4.37X8                  | BOLT, SOCKET M4.37X8                         |    |
| 70-7    | S28734001 | 1    | シリンダドダイ                      | CYLINDER BRACKET                             |    |
| 70-8    | 018681022 | 2    | アナボルト4.37X10                 | BOLT, SOCKET M4.37X10                        |    |
| 70-9    | S28735000 | 1    | エアシリンダクミ                     | AIR CYLINDER ASSY                            |    |
| 70-9-1  | S28736000 | 1    | エアシリンダ                       | AIR CYLINDER                                 |    |
| 70-9-2  | S28742000 | 1    | ハーフユニオン                      | HALF UNION                                   |    |
| 70-10   | S28737001 | 1    | レバークドウピン                     | LEVER DRIVING PIN                            |    |
| 70-11   | S28738000 | 1    | ソレノイドバルブクミ                   | SOLENOID VALVE ASSY                          |    |
| 70-11-1 | S28739000 | 1    | ソレノイドバルブ                     | SOLENOID VALVE                               |    |
| 70-11-2 | S01522000 | 1    | ハーフユニオン                      | HALF UNION                                   |    |
| 70-11-3 | S04910000 | 1    | ハーフユニオン                      | HALF UNION                                   |    |
| 70-11-4 | 159874000 | 1    | サイレンサー                       | SILENCER                                     |    |
| 70-12   | 032422505 | 2    | +マルモクネジ4.1X25                | WOOD SCREW, ROUND M4.1X25                    |    |
| 70-13   | S28740000 | 1    | エアチューブ (L=220)               | AIR TUBE (L=220)                             |    |
| 70-14   | S28741000 | 1    | エアチューブ (L=300)               | AIR TUBE (L=300)                             |    |
| 118-3-3 | S28893001 | 1    | アイゲージ                        | GAUGE PLATE (6.4)                            |    |
| 118-3-4 | S28894001 | 1    | アイゲージ                        | GAUGE PLATE (6.4)                            |    |
| 118-3-5 | S28895001 | 1    | アイゲージ                        | GAUGE PLATE (6.4)                            |    |

From the library of: Diamond Needle Corp

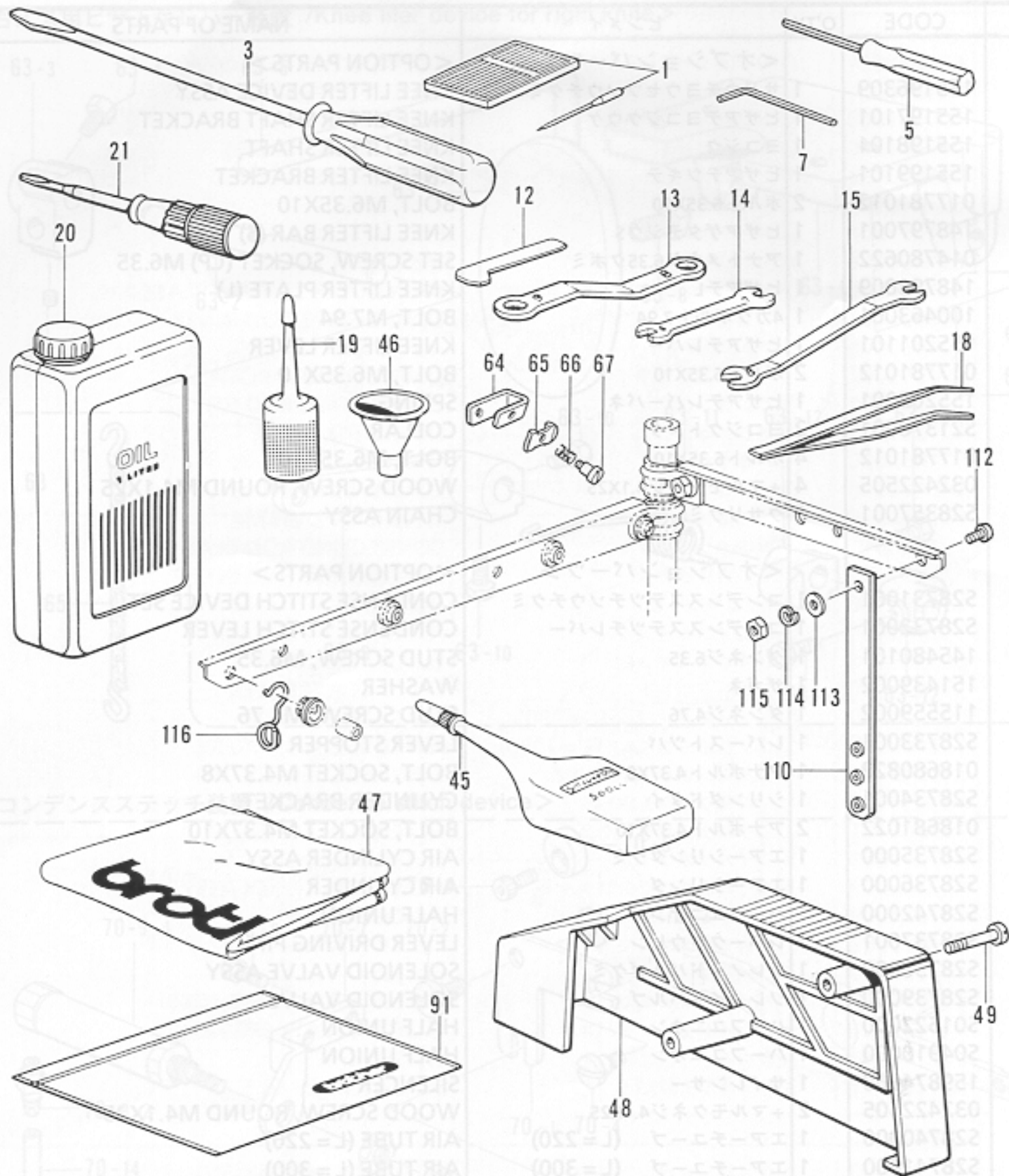

From the library of: Diamond Needle Corp

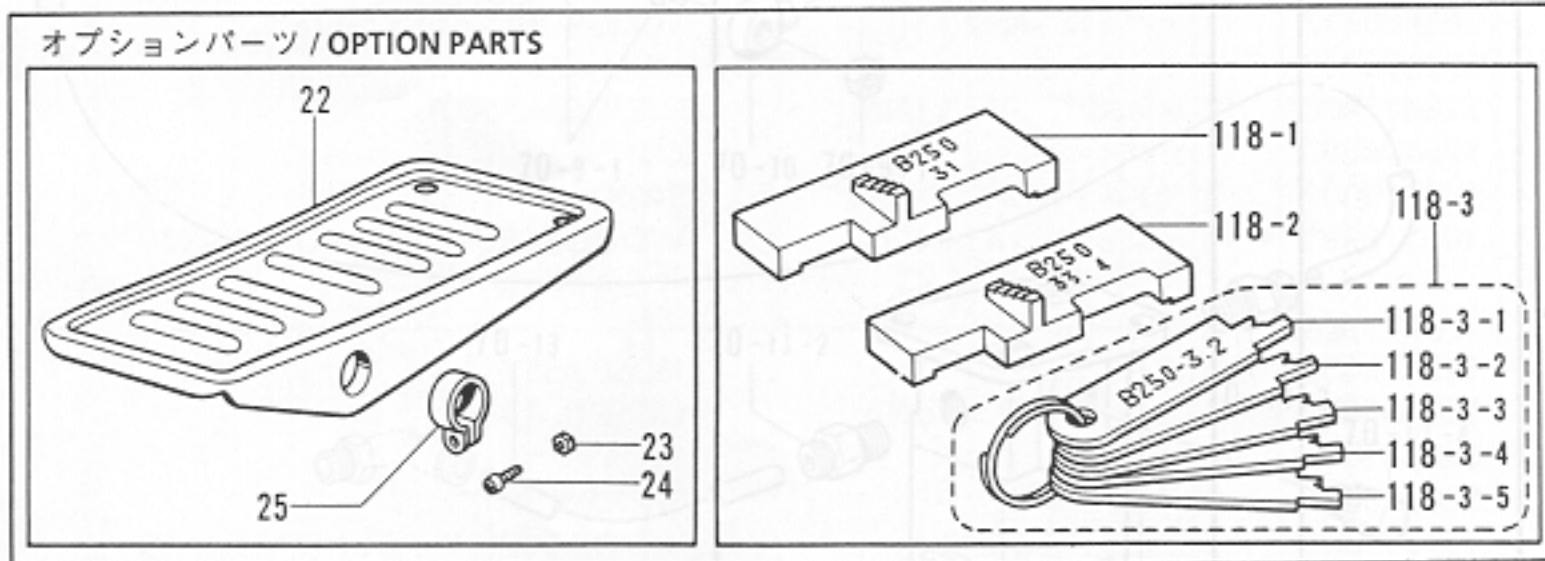

- ◎ 付属品の明細は変更することがあります。
- ◎ The details of included accessories are subject to change.
- ◎ Änderungen in der Aufstellung der Mitgelieferten Zubehöre sind vorbehalten.
- ◎ Les détails des accessoires inclus sont sujets à des changements.
- ◎ Los detalles de los accesorios incluidos pueden variar.

| REF.NO.    | CODE      | Q'TY | ヒンメイ           | NAME OF PARTS           | RM |
|------------|-----------|------|----------------|-------------------------|----|
| 1          | S08715010 | 10   | ミシンハリUYX128GAS | NEEDLE UYX128GAS        |    |
| 3          | 101572101 | 1    | ネジマワシ5.5X190   | SCREW DRIVER 5.5X190    |    |
| 5          | S01943001 | 1    | 6カクボウネジマワシ1.6  | SCREW DRIVER 1.6        |    |
| 7          | 142721001 | 1    | 6カクボウスパナ3      | HEXAGONAL WRENCH 3      |    |
| 12         | 156309001 | 1    | Lガタネジマワシ       | L-TYPE SCREW DRIVER     |    |
| 13         | 105343001 | 1    | メガネレンチ8X9      | WRENCH 8X9              |    |
| 14         | 107779001 | 1    | スパナ6X7         | SPANNER 6X7             |    |
| 15         | 143566001 | 1    | スパナ8           | SPANNER 8               |    |
| 18         | 117466000 | 1    | ピンセット          | PINCETTE                |    |
| 19         | S06701000 | 1    | ポリオイラークミ       | POLY OILER ASSY         |    |
| 20         | 145277105 | 1    | オイルタンク         | OIL TANK                |    |
| 21         | 118837001 | 1    | ネジマワシ3.4X70    | SCREW DRIVER 3.4X70     |    |
| 45         | S06704001 | 1    | シリコンオイル        | SILICONE OIL            |    |
| 46         | 140759000 | 1    | ジョーゴ           | FUNNEL                  |    |
| 47         | 144224001 | 1    | トウブカバー         | HEAD COVER              |    |
| 48         | S09002009 | 1    | ベルトカバー         | BELT COVER              |    |
| 49         | 102424004 | 2    | シメネジ4.37       | SCREW, M4.37            |    |
| 64         | S08984001 | 1    | サブテンションダイ      | SUB TENSION BASE        |    |
| 65         | 112300001 | 1    | ハリイトオサエ        | NEEDLE THREAD CLAMP     |    |
| 66         | 112299001 | 1    | ハリイトアンナイオシバネ   | COIL SPRING             |    |
| 67         | 112301001 | 1    | ダンネジ3.18       | STUD SCREW, M3.18       |    |
| 91         | 122991001 | 1    | フゾクヒンポリフクロ     | ACCESSORY BAG           |    |
| 110        | S21943001 | 1    | イトアンナイクミ       | THREAD GUIDE ASSY       |    |
| 112        | 062501006 | 1    | ナベコ5X10        | SCREW, PAN M5X10        |    |
| 113        | 025050236 | 1    | ヒラザガネチユウ-5     | WASHER, PLAIN M 5       |    |
| 114        | 028050246 | 1    | バネザガネ2-5       | WASHER, SPRING 2-5      |    |
| 115        | 021500106 | 1    | 1シユナツト5        | NUT, 1 M5               |    |
| 116        | S02747101 | 1    | イトカケバネ         | SPRING                  |    |
| <オプションパーツ> |           |      |                | <OPTION PARTS>          |    |
| 22         | 147893009 | 1    | オサエアゲフミイタ      | TREADLE PEDAL           |    |
| 23         | 021400106 | 2    | ナツト1シユ4        | NUT, 1 M4               |    |
| 24         | 062401406 | 2    | ナベコ4X14        | SCREW, PAN M4X14        |    |
| 25         | 116016001 | 2    | ベタルトメ          | PEDAL STOPPER           |    |
| 118        | S28887001 | 1    | デアイゲージセット      | LOOPER TIMING GAUGE SET |    |
| 118-1      | S28888001 | 1    | デアイゲージブロックS    | GAUGE BLOCK (S)         |    |
| 118-2      | S28889001 | 1    | デアイゲージブロックH    | GAUGE BLOCK (H)         |    |
| 118-3      | S28890001 | 1    | デアイゲージイタクミ     | GAUGE PLATE ASSY        |    |
| 118-3-1    | S28891001 | 1    | デアイゲージイタ3.2    | GAUGE PLATE (3.2)       |    |
| 118-3-2    | S28892001 | 1    | デアイゲージイタ4.0    | GAUGE PLATE (4.0)       |    |
| 118-3-3    | S28893001 | 1    | デアイゲージイタ4.8    | GAUGE PLATE (4.8)       |    |
| 118-3-4    | S28894001 | 1    | デアイゲージイタ5.6    | GAUGE PLATE (5.6)       |    |
| 118-3-5    | S28895001 | 1    | デアイゲージイタ6.4    | GAUGE PLATE (6.4)       |    |
|            | 118064001 |      | 6カクボウスパナ4      | HEXAGONAL WRENCH 4      |    |
|            | 154125001 |      | 6カクボウスパナ2.5    | HEXAGONAL WRENCH 2.5    |    |
|            | 12,21,22> |      |                |                         |    |
|            | 21,32,42> |      |                |                         |    |
|            | 149247001 |      | クサリクミ          | CHAIN ASSY              |    |
|            | S09001101 |      | クサリガイド         | CHAIN GUIDE             |    |
|            | 060680712 |      | バインド437-40X7   | SCREW BIND M4 37-40X7   |    |
|            | 14>       |      |                |                         |    |
|            | 34>       |      |                |                         |    |
|            | S21942001 |      | クサリクミ          | CHAIN ASSY              |    |
|            | S09001101 |      | クサリガイド         | CHAIN GUIDE             |    |
|            | 060680712 |      | バインド437-40X7   | SCREW BIND M4 37-40X7   |    |

輸出用 / FOR EXPORT

011  
033  
051  
053  
061  
OX1

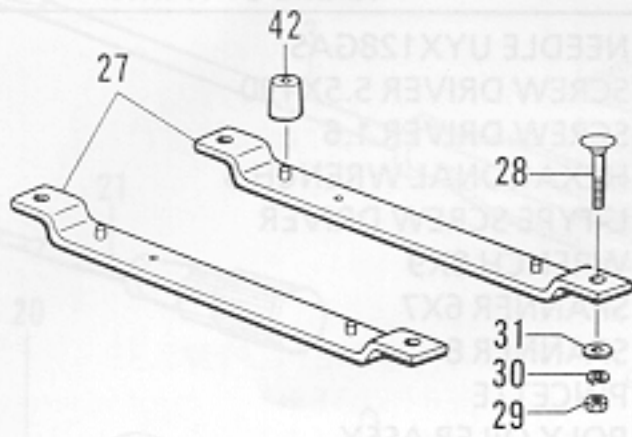

056  
0V1  
0W1  
OX6

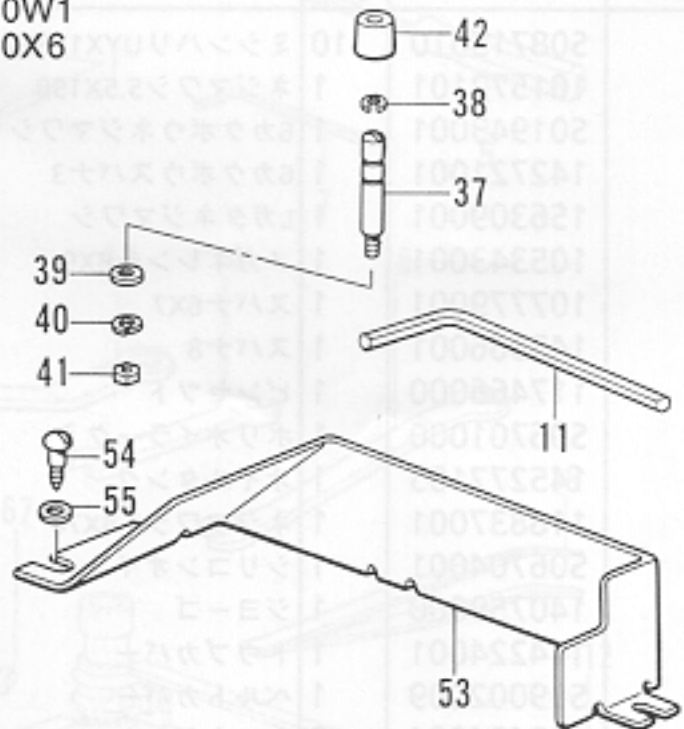

011

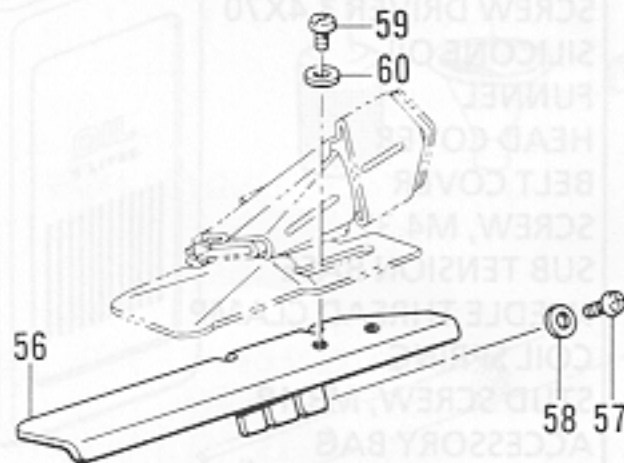

056

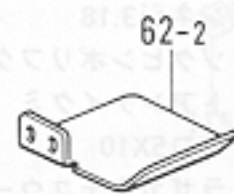

OX6

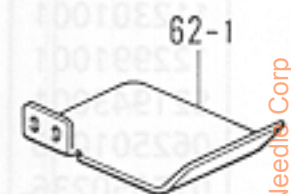

056  
061  
0V1  
0W1  
OX6



011

033  
051  
053

056  
061  
0V1  
0W1



OX1  
OX6



B256-UT11, 12, 21, 22  
B257-UT11, 21, 32, 42

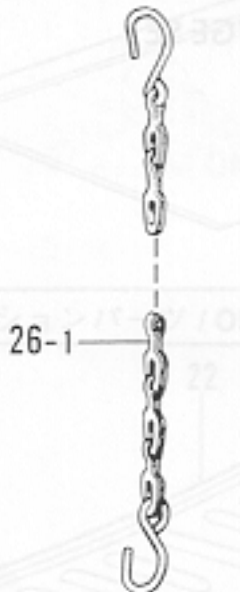

26-1

B256-UT13, 14  
B257-UT13, 34

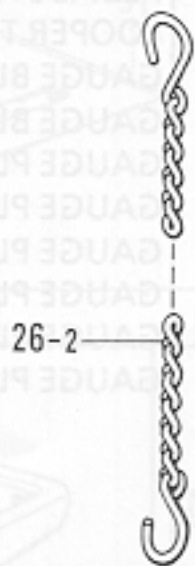

26-2



43

44

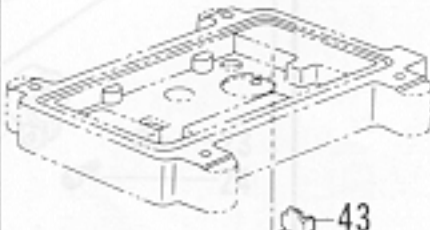

43

44

0W1



2

B257-UT32, 34, 42, 44



10

9

From the library of: Diamond Needle Corp

◎ 付属品の明細は変更することがあります。  
 ◎ The details of included accessories are subject to change.  
 ◎ Änderungen in der Aufstellung der Mitgelieferten Zubehöre sind vorbehalten.  
 ◎ Les détails des accessoires inclus sont sujets à des changements.  
 ◎ Los detalles de los accesorios incluidos pueden variar.

22. 付属品関係 / Accessories / Zubehör / Accessoires / Accesorios

| REF.NO.                                       | CODE      | Q'TY | ヒンメイ         | NAME OF PARTS          | RM |
|---|-----------|------|--------------|------------------------|----|
| <輸出用 / FOR EXPORT > <011,033,051,053,061,0X1> |           |      |              |                        |    |
| 27  | S28830001 | 2    | -----        | HEAD PLATE ASSY        |    |
| 28  | 211964001 | 4    | -----        | BOLT, M8X55            |    |
| 29  | 021080106 | 4    | -----        | NUT, 1 M8              |    |
| 30  | 028080242 | 4    | -----        | WASHER, SPRING 2-8     |    |
| 31  | 025080236 | 4    | -----        | WASHER, PLAIN M 8      |    |
| 42  | 147919002 | 4    | -----        | RUBBER CUSHION         |    |
| <056,0V1,0W1,0X6>                             |           |      |              |                        |    |
| 11  | 115157001 | 1    | 6カクボウスパナ6    | HEXAGONAL WRENCH 6     |    |
| 37  | S28441001 | 4    | ボウシンゴムピン     | RUBBER CUSHION PIN     |    |
| 38  | S28442001 | 4    | トメワU5        | RETAINING RING, U5     |    |
| 39  | 025060236 | 4    | ヒラザガネチユウ6    | WASHER, PLAIN M 6      |    |
| 40  | 028060242 | 4    | バネザガネ2-6     | WASHER, SPRING 2-6     |    |
| 41  | 021060106 | 4    | 1シユナツト6      | NUT, 1 M6              |    |
| 42  | 147919002 | 4    | ボウジンゴム       | RUBBER CUSHION         |    |
| 53  | S28444001 | 1    | ホジヨベルトカバー    | SUB BELT COVER         |    |
| 54  | 100666002 | 3    | マルモクネジ5.5X20 | SCREW, OVAL M5.5X20    |    |
| 55  | 025750132 | 3    | ヒラザガネシヨウ5.56 | WASHER, PLAIN S 5.56   |    |
| <011>   |           |      |              |                        |    |
| 56  | S28445001 | 1    | ホジヨイタ        | SUPPORT PLATE          |    |
| 57  | 062710812 | 2    | ナベコ476-32X8  | SCREW, PAN M4.76-32X8  |    |
| 58  | 113431002 | 2    | ザガネ          | WASHER                 |    |
| 59  | 062710812 | 2    | ナベコ476-32X8  | SCREW, PAN M4.76-32X8  |    |
| 60  | 116662003 | 2    | ザガネ          | WASHER                 |    |
| <056,061,0V1,0W1,0X6>                         |           |      |              |                        |    |
| 16  | 107780001 | 1    | スパナ10X12     | SPANNER 10X12          |    |
| 84  | S09021000 | 1    | グリス          | GREASE                 |    |
| <056>   |           |      |              |                        |    |
| 62-2  | S28107101 | 1    | ヌノオサエ        | CLOTH PRESSER          |    |
| <0X6>   |           |      |              |                        |    |
| 62-1  | S28105001 | 1    | ヌノオサエ        | CLOTH PRESSER          |    |
| <011,033,051,053,056,061,0V1,0W1>             |           |      |              |                        |    |
| 4   | 146700001 | 1    | 6カクボウネジマワシ2  | SCREW DRIVER 2         |    |
| <0X1,0X6>                                     |           |      |              |                        |    |
| 6   | 146049001 | 1    | 6カクボウスパナ2    | HEXAGONAL WRENCH 2     |    |
| <0W1>   |           |      |              |                        |    |
| 2   | S28849000 | 1    | ネジマワシ6X35    | SCREW DRIVER 6X35      |    |
| <B257-UT32,34,42,44>                          |           |      |              |                        |    |
| 9   | 118064001 | 1    | 6カクボウスパナ4    | HEXAGONAL WRENCH 4     |    |
| 10  | 154125001 | 1    | 6カクボウスパナ2.5  | HEXAGONAL WRENCH 2.5   |    |
| <B256-UT11,12,21,22>                          |           |      |              |                        |    |
| <B257-UT11,21,32,42>                          |           |      |              |                        |    |
| 26-1  | 149247001 | 1    | クサリクミ        | CHAIN ASSY             |    |
| 43  | S09001101 | 1    | クサリガイド       | CHAIN GUIDE            |    |
| 44  | 060680712 | 1    | バインド437-40X7 | SCREW, BIND M4.37-40X7 |    |
| <B256-UT13,14>                                |           |      |              |                        |    |
| <B257-UT13,34>                                |           |      |              |                        |    |
| 26-2  | S21942001 | 1    | クサリクミ        | CHAIN ASSY             |    |
| 43  | S09001101 | 1    | クサリガイド       | CHAIN GUIDE            |    |
| 44  | 060680712 | 1    | バインド437-40X7 | SCREW, BIND M4.37-40X7 |    |

From the library of: Diamond Needle Corp

B256

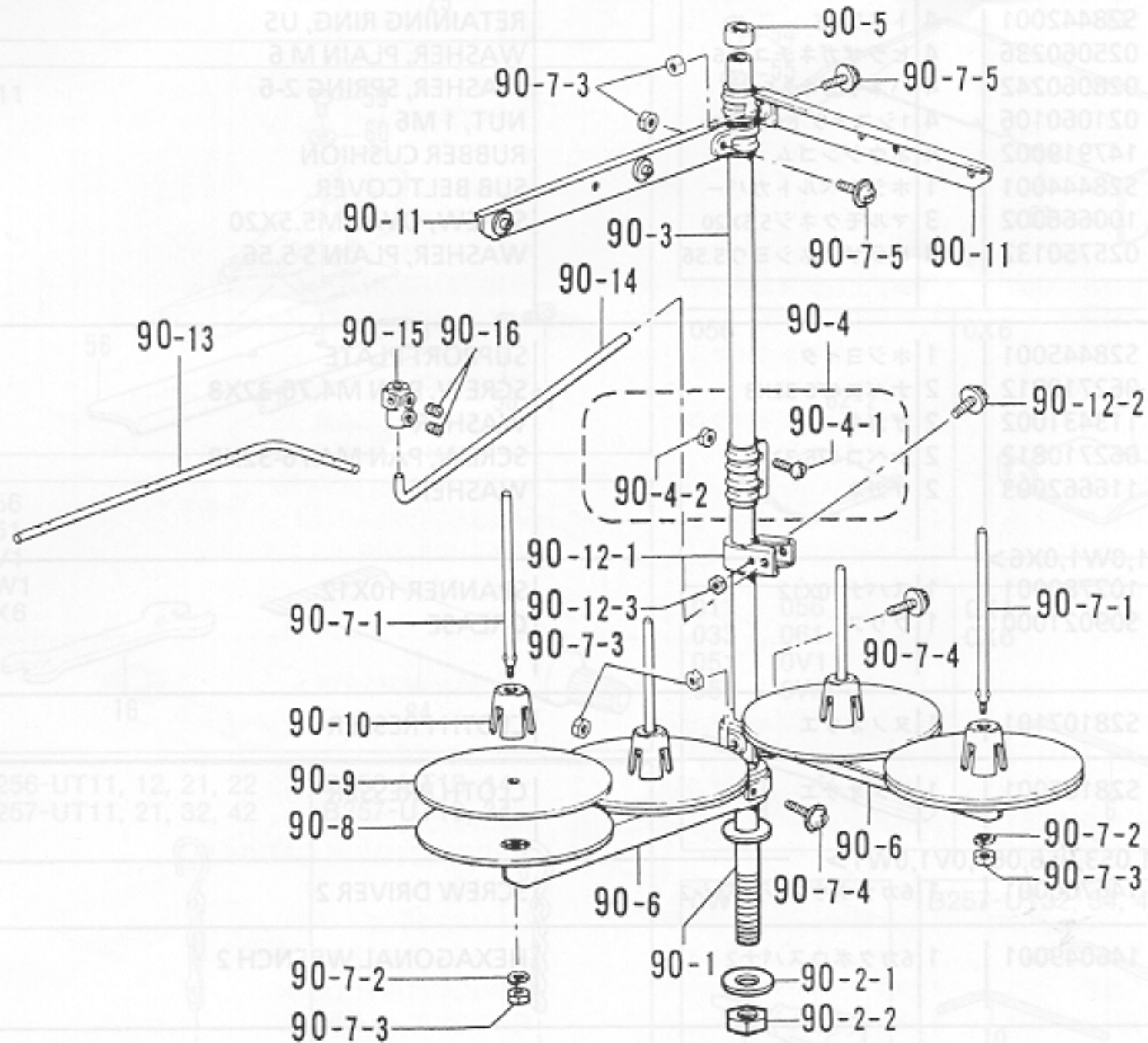

- ◎ 付属品の明細は変更することがあります。
- ◎ The details of included accessories are subject to change.
- ◎ Änderungen in der Aufstellung der Mitgelieferten Zubehöre sind vorbehalten.
- ◎ Les détails des accessoires inclus sont sujets à des changements.
- ◎ Los detalles des accesorios incluidos pueden variar.

| REF.NO. | CODE      | Q'TY | ヒンメイ                      | NAME OF PARTS                | RM |
|---------|-----------|------|---------------------------|------------------------------|----|
|         |           |      | <B256>                    |                              |    |
| 90      | S29854009 | 1    | イトタテダイクミ4DTHF             | COTTON STAND ASSY 4DTHF      |    |
| 90-1    | 156112003 | 1    | コラムパイプD                   | COLUMN PIPE (D)              |    |
| 90-2    | S02775001 | 1    | パイプネジセットA                 | PIPE SCREW SET (A)           |    |
| 90-2-1  | 150206002 | 1    | ヒラザガネ16                   | WASHER, PLAIN 16             |    |
| 90-2-2  | 150191002 | 1    | 6カクナツト5/8                 | NUT, 5/8                     |    |
| 90-3    | 150172003 | 1    | コラムパイプ                    | COLUMN PIPE                  |    |
| 90-4    | 150106003 | 1    | コラムジョイントクミ                | COLUMN JOINT ASSY            |    |
| 90-4-1  | 062501406 | 2    | ナベコ5X14                   | SCREW, PAN M5X14             |    |
| 90-4-2  | 021500106 | 2    | 1シユナツト5                   | NUT, 1 M5                    |    |
| 90-5    | 150174000 | 1    | コラムキャップ                   | COLUMN CAP                   |    |
| 90-6    | S02778002 | 2    | スプールホルダー2                 | SPOOL HOLDER 2               |    |
| 90-7    | S02780001 | 2    | スプールネジセット2                | SPOOL SCREW SET 2            |    |
| 90-7-1  | 150179002 | 4    | スプールジク                    | SPOOL SHAFT (B)              |    |
| 90-7-2  | 028050246 | 4    | バネザガネ2-5                  | WASHER, SPRING 2-5           |    |
| 90-7-3  | 021500106 | 8    | 1シユナツト5                   | NUT, 1 M5                    |    |
| 90-7-4  | 0A1503006 | 2    | +ナベザクミ5X30A               | SCREW, PAN (P WASHER) M5X30A |    |
| 90-7-5  | 0A1501406 | 2    | +ナベザクミ5X14A               | SCREW, PAN (P WASHER) M5X14A |    |
| 90-8    | 150180001 | 4    | ウケザラ                      | SPOOL STAND BASE             |    |
| 90-9    | 150182000 | 4    | スプリームツ                    | SPOOL MAT                    |    |
| 90-10   | 126863001 | 4    | スプリームクッション                | SPOOL CUSHION                |    |
| 90-11   | S02786002 | 2    | スレツドハンガークミ2               | THREAD HANGER ASSY 2         |    |
| 90-12   | 150145009 | 1    | イトアンナイホルダークミ              | THREAD GUIDE HOLDER ASSY     |    |
| 90-12-1 | 150185009 | 1    | イトアンナイホルダー                | THREAD GUIDE HOLDER          |    |
| 90-12-2 | 0A1503006 | 1    | +ナベザクミ5X30A               | SCREW, PAN (P WASHER) M5X30A |    |
| 90-12-3 | 021500106 | 1    | 1シユナツト5                   | NUT, 1 M5                    |    |
| 90-13   | 142998101 | 1    | イトアンナイ4                   | THREAD GUIDE 4               |    |
| 90-14   | S04109001 | 1    | イトアンナイササエボウ               | THREAD GUIDE SUPPORT BAR     |    |
| 90-15   | 138843001 | 1    | ササエボウツギテ                  | JOINT                        |    |
| 90-16   | 014060632 | 2    | アナトメ6X6クボミ                | SET SCREW, SOCKET (CP) M6X6  |    |
| 91-13-2 | 062501406 | 2    | ナベコ5X14                   | SCREW, PAN M5X14             |    |
| 91-13-3 | 021500106 | 2    | 1シユナツト5                   | NUT, 1 M5                    |    |
| 91-13-4 | 031122005 | 2    | WOOD SCREW, ROUND M4.5X22 | WOOD SCREW, ROUND M4.5X22    |    |
| 91-14   | S02786002 | 2    | スレツドハンガークミ2               | THREAD HANGER ASSY 2         |    |
| 91-15   | S02780001 | 2    | スプールネジセット2                | SPOOL SCREW SET 2            |    |
| 91-16   | 150185009 | 1    | イトアンナイホルダー                | THREAD GUIDE HOLDER          |    |
| 91-16-1 | 150185009 | 1    | イトアンナイホルダー                | THREAD GUIDE HOLDER          |    |
| 91-16-2 | 0A1503006 | 1    | +ナベザクミ5X30A               | SCREW, PAN (P WASHER) M5X30A |    |
| 91-16-3 | 021500106 | 1    | 1シユナツト5                   | NUT, 1 M5                    |    |
| 91-17   | 142999101 | 1    | イトアンナイ4                   | THREAD GUIDE 4               |    |
| 91-18   | S04109001 | 1    | イトアンナイササエボウ               | THREAD GUIDE SUPPORT BAR     |    |
| 91-19   | 138843001 | 1    | ササエボウツギテ                  | JOINT                        |    |
| 91-20   | 014060632 | 2    | アナトメ6X6クボミ                | SET SCREW, SOCKET (CP) M6X6  |    |

From the library of: Diamond Needle Corp



B257

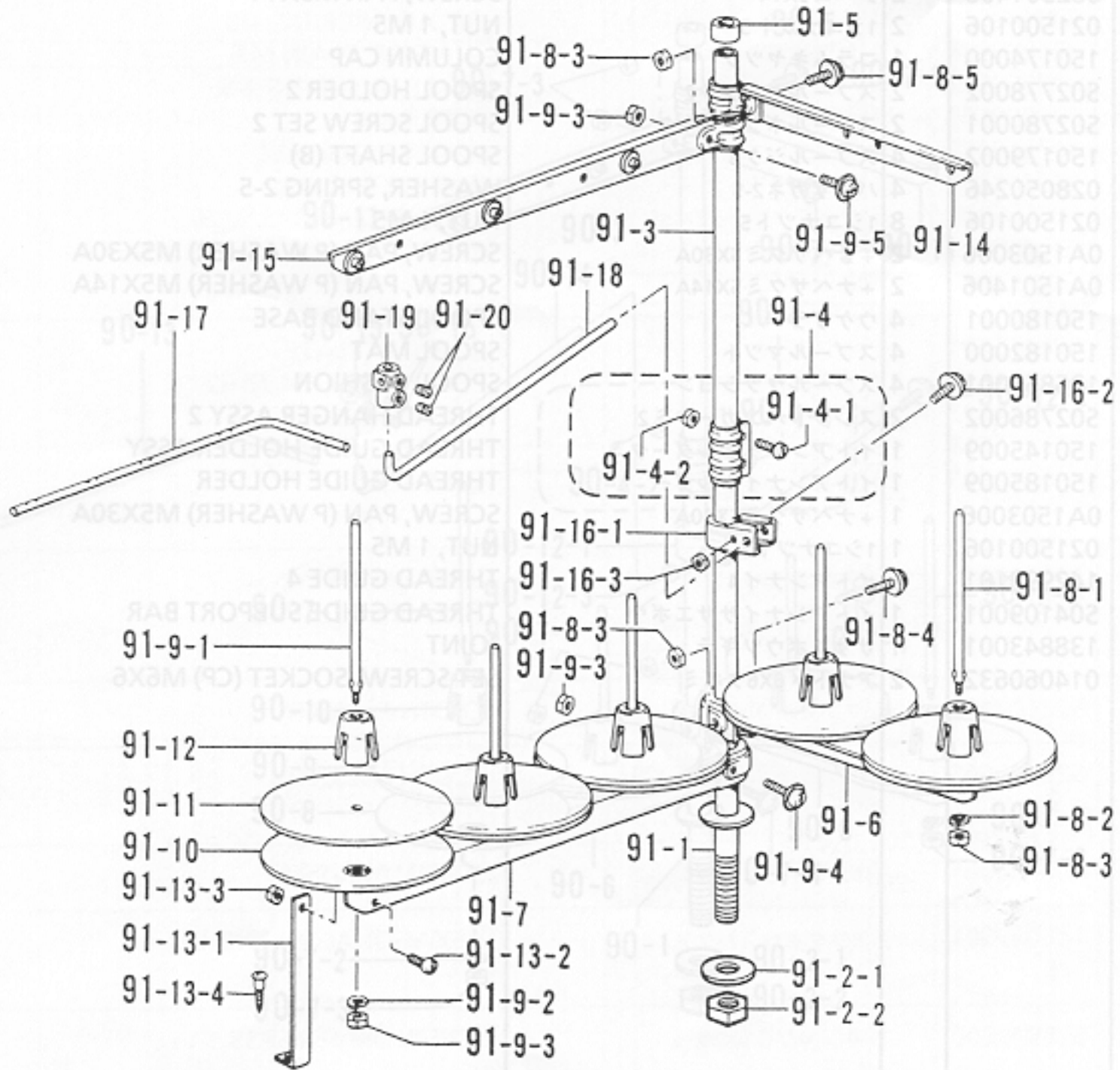

From the library of: Diamond Needle Corp

- ◎ 付属品の明細は変更することがあります。
- ◎ The details of included accessories are subject to change.
- ◎ Änderungen in der Aufstellung der Mitgelieferten Zubehöre sind vorbehalten.
- ◎ Les détails des accessoires inclus sont sujets à des changements.
- ◎ Los detalles de los accesorios incluidos pueden variar.

Z4. 付属品関係 / Accessories / Zubehör / Accessoires / Accesorios

| REF.NO. | CODE      | Q'TY | ヒンメイ          | NAME OF PARTS                | RM |
|---------|-----------|------|---------------|------------------------------|----|
|         |           |      | <B257>        |                              |    |
| 91      | S29855009 | 1    | イトタテダイクミ5DTHF | COTTON STAND ASSY (5DTHF)    |    |
| 91-1    | 156112003 | 1    | コラムパイプD       | COLUMN PIPE (D)              |    |
| 91-2    | S02775001 | 1    | パイプネジセットA     | PIPE SCREW SET (A)           |    |
| 91-2-1  | 150206002 | 1    | ヒラザガネ16       | WASHER, PLAIN 16             |    |
| 91-2-2  | 150191002 | 1    | 6カクナツト5/8     | NUT, 5/8                     |    |
| 91-3    | 150172003 | 1    | コラムパイプ        | COLUMN PIPE                  |    |
| 91-4    | 150106003 | 1    | コラムジョイントクミ    | COLUMN JOINT ASSY            |    |
| 91-4-1  | 062501406 | 2    | ナベコ5X14       | SCREW, PAN M5X14             |    |
| 91-4-2  | 021500106 | 2    | 1シユナツト5       | NUT, 1 M5                    |    |
| 91-5    | 150174000 | 1    | コラムキャップ       | COLUMN CAP                   |    |
| 91-6    | S02778002 | 1    | スプールホルダー2     | SPOOL HOLDER 2               |    |
| 91-7    | S02779009 | 1    | スプールホルダー3     | SPOOL HOLDER 3               |    |
| 91-8    | S02780001 | 1    | スプールネジセット2    | SPOOL SCREW SET 2            |    |
| 91-8-1  | 150179002 | 2    | スプールジクB       | SPOOL SHAFT (B)              |    |
| 91-8-2  | 028050246 | 2    | バネザガネ2-5      | WASHER, SPRING 2-5           |    |
| 91-8-3  | 021500106 | 4    | 1シユナツト5       | NUT, 1 M5                    |    |
| 91-8-4  | 0A1503006 | 1    | +ナベザクミ5X30A   | SCREW, PAN (P WASHER) M5X30A |    |
| 91-8-5  | 0A1501406 | 1    | +ナベザクミ5X14A   | SCREW, PAN (P WASHER) M5X14A |    |
| 91-9    | S02782001 | 1    | スプールネジセット3    | SPOOL SCREW SET 3            |    |
| 91-9-1  | 150179002 | 3    | スプールジクB       | SPOOL SHAFT (B)              |    |
| 91-9-2  | 028050246 | 3    | バネザガネ2-5      | WASHER, SPRING 2-5           |    |
| 91-9-3  | 021500106 | 5    | 1シユナツト5       | NUT, 1 M5                    |    |
| 91-9-4  | 0A1503006 | 1    | +ナベザクミ5X30A   | SCREW, PAN (P WASHER) M5X30A |    |
| 91-9-5  | 0A1501406 | 1    | +ナベザクミ5X14A   | SCREW, PAN (P WASHER) M5X14A |    |
| 91-10   | 150180001 | 5    | ウケザラ          | SPOOL STAND BASE             |    |
| 91-11   | 150182000 | 5    | スプールのマット      | SPOOL MAT                    |    |
| 91-12   | 126863001 | 5    | スプールのクッション    | SPOOL CUSHION                |    |
| 91-13   | S02784009 | 1    | ホルダーササエAセット   | HOLDER SUPPORT (A) SET       |    |
| 91-13-1 | 150188009 | 1    | スプールホルダーササエA  | SPOOL HOLDER SUPPORT (A)     |    |
| 91-13-2 | 062501006 | 1    | ナベコ5X10       | SCREW, PAN M5X10             |    |
| 91-13-3 | 021500106 | 1    | 1シユナツト5       | NUT, 1 M5                    |    |
| 91-13-4 | 031452206 | 1    | マルモク45X22     | WOOD SCREW, ROUND M4.5X22    |    |
| 91-14   | S02786002 | 1    | スレツドハンガークミ2   | THREAD HANGER ASSY 2         |    |
| 91-15   | S02788009 | 1    | スレツドハンガークミ3   | THREAD HANGER ASSY 3         |    |
| 91-16   | 150145009 | 1    | イトアンナイホルダークミ  | THREAD GUIDE HOLDER ASSY     |    |
| 91-16-1 | 150185009 | 1    | イトアンナイホルダー    | THREAD GUIDE HOLDER          |    |
| 91-16-2 | 0A1503006 | 1    | +ナベザクミ5X30A   | SCREW, PAN (P WASHER) M5X30A |    |
| 91-16-3 | 021500106 | 1    | 1シユナツト5       | NUT, 1 M5                    |    |
| 91-17   | 142999101 | 1    | イトアンナイ5       | THREAD GUIDE 5               |    |
| 91-18   | S04109001 | 1    | イトアンナイササエボウ   | THREAD GUIDE SUPPORT BAR     |    |
| 91-19   | 138843001 | 1    | ササエボウツギテ      | JOINT                        |    |
| 91-20   | 014060632 | 2    | アナトメ6X6クボミ    | SET SCREW, SOCKET (CP) M6X6  |    |

From the library of: Diamond Needle Corp

索引/INDEX/VERZEICHIS/  
INDEX/INDICE

| CODE      | REF.NO.      | Page |
|-----------|--------------|------|
| J00102001 | Q - 1        | 58   |
| J00103001 | Q - 1-9      | 58   |
| S00075000 | A4 - 14-1-3  | 12   |
| S00313009 | A1 - 31      | 2    |
| S00356001 | K1 - 51      | 38   |
|           | K2 - 51      | 42   |
| S00383001 | K1 - 52      | 38   |
|           | K2 - 52      | 42   |
| S00480000 | X1 - 20-1    | 78   |
|           | X1 - 20-2    | 78   |
| S00879001 | C1 - 25      | 18   |
| S01295001 | A2 - 139     | 6    |
|           | S1 - 1-27    | 60   |
|           | S2 - 1-27    | 64   |
| S01297001 | X2 - 50-9    | 80   |
| S01374001 | C2 - 40-1-4  | 20   |
|           | C2 - 40-2-4  | 20   |
|           | C2 - 40-3-4  | 20   |
|           | C2 - 40-6-4  | 22   |
| S01522000 | V - 7-1-2    | 72   |
|           | S2 - 66-2    | 66   |
|           | X3 - 70-11-2 | 82   |
| S01542000 | S2 - 66-3    | 66   |
|           | X2 - 40-21   | 80   |
| S01561000 | X2 - 40-2    | 80   |
| S01694001 | S1 - 1-25    | 60   |
|           | S2 - 1-25    | 64   |
| S01696001 | M - 96       | 50   |
|           | T - 14       | 68   |
| S01696002 | A1 - 89      | 4    |
| S01943001 | Z1 - 5       | 84   |
| S02556001 | M - 33       | 48   |
| S02592009 | U - 1-1-5    | 70   |
| S02606000 | A1 - 5       | 2    |
| S02745001 | U - 1-1-3-4  | 70   |
|           | S1 - 45      | 62   |
|           | S2 - 45      | 66   |
| S02747101 | Z1 - 116     | 84   |
| S02775001 | Z3 - 90-2    | 88   |
|           | Z4 - 91-2    | 90   |
| S02778002 | Z3 - 90-6    | 88   |
|           | Z4 - 91-6    | 90   |
| S02779009 | Z4 - 91-7    | 90   |
| S02780001 | Z3 - 90-7    | 88   |
|           | Z4 - 91-8    | 90   |
| S02782001 | Z4 - 91-9    | 90   |
| S02784009 | Z4 - 91-13   | 90   |
| S02786002 | Z3 - 90-11   | 88   |
|           | Z4 - 91-14   | 90   |
| S02788009 | Z4 - 91-15   | 90   |
| S02874001 | D - 4-3      | 22   |
| S03421001 | J - 13       | 36   |
| S04109001 | Z3 - 90-14   | 88   |
|           | Z4 - 91-18   | 90   |
| S04159000 | S1 - 44      | 62   |
|           | S1 - 54      | 62   |
|           | S2 - 44      | 66   |
|           | S2 - 54      | 66   |
| S04896000 | V - 3-1      | 72   |
|           | X1 - 2-1     | 78   |
| S04910000 | X3 - 70-11-3 | 82   |
| S05246000 | E2 - 102     | 28   |
| S05981000 | U - 1-1-3-8  | 70   |
| S05982000 | U - 1-1-3-9  | 70   |
| S06701000 | Z1 - 19      | 84   |

| CODE      | REF.NO.     | Page |
|-----------|-------------|------|
| S06704001 | Z1 - 45     | 84   |
| S07027001 | X1 - 16-6   | 78   |
| S07317001 | A4 - 14-1-6 | 12   |
|           | A4 - 14-2-6 | 12   |
| S07350001 | T - 2       | 68   |
| S08138000 | X2 - 43     | 80   |
| S08238000 | K1 - 107    | 40   |
|           | K2 - 107    | 44   |
| S08627001 | A1 - 2-1    | 2    |
| S08628000 | A1 - 3      | 2    |
| S08629009 | A1 - 12-1   | 2    |
| S08630201 | A1 - 16-1   | 2    |
| S08631000 | A1 - 17     | 2    |
| S08632009 | A1 - 23-1   | 2    |
| S08682001 | B - 3       | 14   |
| S08683000 | B - 4       | 14   |
| S08684101 | B - 6       | 14   |
| S08685001 | B - 6-1     | 14   |
| S08686101 | B - 6-2     | 14   |
| S08688001 | B - 9       | 14   |
| S08692101 | B - 17      | 14   |
| S08693001 | B - 17-1    | 14   |
| S08694001 | B - 17-2    | 14   |
| S08696000 | B - 24      | 14   |
| S08697000 | B - 25      | 14   |
| S08698001 | B - 26      | 14   |
| S08715010 | B - 31      | 16   |
|           | B - 31      | 16   |
|           | Z1 - 1      | 84   |
| S08758009 | D - 1       | 22   |
| S08760009 | D - 1-1     | 22   |
| S08761100 | D - 3       | 22   |
| S08769001 | C1 - 6      | 18   |
| S08770000 | C1 - 12     | 18   |
|           | K1 - 49     | 38   |
|           | K2 - 49     | 42   |
| S08771001 | C1 - 14     | 18   |
| S08774001 | C1 - 18     | 18   |
| S08775000 | C1 - 28     | 18   |
| S08776001 | C1 - 30     | 18   |
| S08777001 | C1 - 31     | 18   |
|           | K1 - 114    | 40   |
|           | K2 - 114    | 44   |
| S08782101 | C2 - 40-1-1 | 20   |
|           | C2 - 40-2-1 | 20   |
|           | C2 - 40-3-1 | 20   |
| S08783101 | C2 - 40-1-3 | 20   |
|           | C2 - 40-2-3 | 20   |
|           | C2 - 40-3-3 | 20   |
|           | C2 - 40-6-3 | 22   |
| S08784001 | C2 - 40-1-6 | 20   |
|           | C2 - 40-2-6 | 20   |
|           | C2 - 40-3-6 | 20   |
|           | C2 - 40-6-6 | 22   |
| S08785001 | C2 - 40-1-8 | 20   |
|           | C2 - 40-2-8 | 20   |
|           | C2 - 40-3-8 | 20   |
| S08806101 | C2 - 40-4-2 | 20   |
|           | C2 - 40-5-2 | 22   |
| S08807101 | C2 - 40-4-4 | 20   |
|           | C2 - 40-5-4 | 22   |
| S08808001 | C2 - 40-4-7 | 20   |
|           | C2 - 40-5-7 | 22   |
| S08809001 | C2 - 40-4-9 | 20   |
|           | C2 - 40-5-9 | 22   |

| CODE      | REF.NO.      | Page |
|-----------|--------------|------|
| S08810001 | C2 - 40-4-10 | 20   |
|           | C2 - 40-5-10 | 22   |
| S08812001 | C2 - 40-4-14 | 20   |
|           | C2 - 40-5-16 | 22   |
| S08889101 | F - 1        | 30   |
| S08890001 | F - 1-1      | 30   |
| S08892001 | F - 7        | 30   |
| S08923101 | J - 1        | 36   |
| S08925000 | J - 1-2      | 36   |
| S08926101 | J - 4        | 36   |
| S08927001 | J - 10       | 36   |
| S08928001 | J - 15       | 36   |
| S08931001 | J - 19       | 36   |
| S08932000 | J - 20       | 36   |
| S08933001 | J - 24       | 36   |
| S08943000 | H - 10       | 34   |
| S08944001 | H - 11       | 34   |
| S08945001 | H - 14       | 34   |
| S08946000 | H - 16       | 34   |
| S08947001 | H - 17       | 34   |
| S08948001 | H - 20       | 34   |
| S08956000 | H - 44       | 34   |
| S08957001 | H - 45       | 34   |
| S08961101 | K1 - 1       | 38   |
|           | K2 - 1       | 42   |
| S08962109 | K1 - 6       | 38   |
|           | K2 - 6       | 42   |
| S08963001 | K1 - 10      | 38   |
|           | K2 - 10      | 42   |
| S08969101 | K1 - 40      | 38   |
|           | K2 - 40      | 42   |
| S08970001 | K1 - 91      | 38   |
|           | K1 - 126     | 40   |
|           | K2 - 43      | 42   |
|           | K2 - 91      | 44   |
|           | K2 - 126     | 44   |
| S08971201 | K1 - 45      | 38   |
|           | K2 - 45      | 42   |
| S08973101 | K1 - 45-2    | 38   |
|           | K2 - 45-2    | 42   |
| S08976001 | K1 - 50      | 38   |
|           | K2 - 50      | 42   |
| S08977001 | K1 - 54      | 38   |
|           | K2 - 54      | 42   |
| S08978001 | K1 - 57      | 38   |
|           | K2 - 57      | 42   |
| S08979001 | K2 - 60      | 42   |
| S08980001 | K2 - 61      | 42   |
| S08981001 | K1 - 68      | 38   |
|           | K2 - 68      | 42   |
| S08982001 | K1 - 70      | 38   |
|           | K2 - 70      | 42   |
| S08983001 | K1 - 72      | 38   |
|           | K2 - 72      | 42   |
| S08984001 | Z1 - 64      | 84   |
| S08985001 | K2 - 79      | 42   |
| S08986001 | K2 - 81      | 44   |
| S08987001 | K2 - 82      | 44   |
| S08988001 | K2 - 86      | 44   |
| S09001101 | Z2 - 43      | 86   |
|           | Z2 - 43      | 86   |
| S09002009 | Z1 - 48      | 84   |
| S09021000 | Z2 - 84      | 86   |
| S09039001 | M - 36-2     | 48   |
| S09043000 | N1 - 19      | 52   |

| CODE      | REF.NO.    | Page |
|-----------|------------|------|
| S09043000 | S1 - 22    | 60   |
|           | S2 - 22    | 64   |
| S09120001 | B - 17-3   | 14   |
| S09121001 | B - 44     | 14   |
|           | B - 44     | 16   |
|           | N2 - 143   | 54   |
| S09124001 | N2 - 104   | 54   |
| S09637001 | U - 1-1-12 | 70   |
| S10243000 | R - 29     | 58   |
|           | X2 - 44-1  | 80   |
|           | X2 - 44-2  | 80   |
| S10656001 | J - 1-1    | 36   |
| S10657001 | K1 - 45-1  | 38   |
|           | K2 - 45-1  | 42   |
| S10696027 | A1 - 114   | 4    |
| S10696028 | A1 - 114   | 4    |
| S10696029 | A1 - 114   | 4    |
| S10696030 | A1 - 114   | 4    |
| S10696031 | A1 - 114   | 4    |
| S10696032 | A1 - 114   | 4    |
| S10696033 | A1 - 114   | 4    |
| S10696034 | A1 - 114   | 4    |
| S10696035 | A1 - 114   | 4    |
| S10696036 | A1 - 114   | 4    |
| S10696037 | A1 - 114   | 4    |
| S10696038 | A1 - 114   | 4    |
| S10696039 | A1 - 114   | 4    |
| S11624000 | N1 - 57    | 52   |
| S12696001 | N1 - 28    | 52   |
|           | N2 - 131   | 54   |
| S12703001 | A2 - 2-2   | 6    |
|           | A3 - 2-2   | 8    |
|           | A4 - 2-2   | 10   |
|           | A4 - 2-2   | 10   |
| S12718000 | F - 15     | 30   |
|           | E1 - 91    | 26   |
| S12724001 | B - 8      | 14   |
| S12725101 | B - 11-2   | 16   |
| S12806001 | F - 9-1    | 30   |
| S12806002 | F - 9-2    | 30   |
| S12806003 | F - 9-3    | 30   |
| S12821001 | M - 1-4    | 48   |
| S12827000 | E1 - 95    | 26   |
| S12846001 | H - 24     | 34   |
| S12858000 | M - 46-1   | 50   |
| S12900001 | M - 36-5   | 48   |
| S12913201 | M - 1-1    | 48   |
| S12915001 | G - 27-1-3 | 32   |
|           | M - 1-2    | 48   |
| S12916001 | M - 1-3    | 48   |
| S12918000 | M - 14     | 48   |
| S12919001 | M - 16     | 48   |
| S12920001 | M - 18     | 48   |
| S12921001 | M - 19     | 48   |
| S12922001 | M - 20     | 48   |
| S12923001 | M - 22     | 48   |
| S12924001 | M - 26     | 48   |
| S12933001 | M - 32     | 48   |
| S12934101 | M - 36     | 48   |
| S12936001 | M - 37     | 48   |
| S12937101 | M - 39     | 48   |
| S12939001 | M - 43     | 48   |
| S12942001 | M - 49     | 50   |
| S12943001 | M - 51     | 50   |
| S12946001 | M - 59     | 50   |
| S12987001 | H - 42     | 34   |
| S13385001 | N2 - 105   | 54   |
| S13414201 | M - 1      | 48   |

| CODE      | REF.NO.    | Page |
|-----------|------------|------|
| S13415101 | M - 36-1   | 48   |
| S13809001 | J - 6      | 36   |
|           | N2 - 116   | 54   |
| S14085011 | R - 25     | 58   |
| S14145000 | X1 - 10-2  | 78   |
| S14621001 | B - 1-2    | 14   |
| S14622001 | F - 1-2    | 30   |
| S17773001 | M - 2      | 48   |
| S20500001 | E1 - 87-1  | 26   |
| S20500002 | E1 - 87-2  | 26   |
| S20500003 | E1 - 87-3  | 26   |
| S20549101 | E1 - 77    | 26   |
| S20550002 | E1 - 78    | 26   |
| S20560001 | E1 - 79    | 26   |
| S20598000 | G - 2      | 32   |
| S21352001 | V - 2-1    | 72   |
|           | X1 - 1-1   | 78   |
| S21353001 | V - 2-2    | 72   |
|           | X1 - 1-2   | 78   |
| S21356001 | X2 - 40-1  | 80   |
| S21357001 | X2 - 40-6  | 80   |
| S21358001 | X2 - 40-8  | 80   |
| S21359001 | X2 - 40-11 | 80   |
| S21360001 | X2 - 40-12 | 80   |
| S21361001 | X2 - 40-13 | 80   |
| S21362000 | X2 - 40-14 | 80   |
| S21378001 | X3 - 63-12 | 82   |
| S21829001 | C1 - 1     | 18   |
| S21830001 | C1 - 4     | 18   |
| S21867001 | R - 1      | 58   |
| S21868101 | R - 3      | 58   |
| S21871101 | R - 4      | 58   |
| S21872101 | R - 6      | 58   |
| S21873001 | R - 8      | 58   |
| S21874000 | R - 9      | 58   |
| S21875001 | R - 10     | 58   |
| S21876001 | R - 12     | 58   |
| S21877001 | R - 14     | 58   |
| S21878001 | K1 - 11    | 38   |
|           | K2 - 11    | 42   |
| S21879001 | K1 - 27    | 38   |
|           | K2 - 27    | 42   |
| S21880001 | K1 - 28    | 38   |
|           | K2 - 28    | 42   |
| S21881001 | K1 - 29    | 38   |
|           | K2 - 29    | 42   |
| S21882001 | K1 - 30    | 38   |
|           | K2 - 30    | 42   |
| S21883001 | K1 - 31    | 38   |
|           | K2 - 31    | 42   |
| S21884001 | K1 - 142   | 40   |
|           | K2 - 142   | 44   |
| S21885001 | K1 - 144   | 40   |
|           | K2 - 144   | 44   |
| S21886001 | K1 - 146   | 40   |
|           | K2 - 146   | 44   |
| S21887001 | K1 - 147   | 40   |
|           | K2 - 147   | 44   |
| S21888001 | K1 - 150   | 40   |
|           | K2 - 150   | 44   |
| S21891001 | K1 - 151   | 40   |
|           | K2 - 151   | 44   |
| S21893001 | K1 - 153   | 40   |
|           | K2 - 153   | 44   |
| S21894001 | K1 - 156   | 40   |
|           | K2 - 156   | 44   |
| S21895001 | S1 - 20    | 60   |
| S21896001 | S1 - 20-1  | 60   |

| CODE      | REF.NO.     | Page |
|-----------|-------------|------|
| S21897000 | S1 - 20-2   | 60   |
| S21898001 | S1 - 20-3   | 60   |
| S21899000 | U - 1-1-2-2 | 70   |
|           | S1 - 20-5   | 60   |
| S21900001 | S1 - 20-7   | 60   |
|           | S2 - 63     | 66   |
| S21901001 | S1 - 21     | 60   |
| S21902001 | S1 - 25     | 62   |
|           | S2 - 25     | 64   |
| S21903001 | S1 - 29     | 62   |
|           | S2 - 29     | 64   |
| S21904101 | S1 - 32     | 62   |
|           | S2 - 32     | 64   |
| S21906001 | S1 - 9      | 60   |
|           | S2 - 9      | 64   |
| S21907001 | S1 - 11     | 60   |
|           | S2 - 11     | 64   |
| S21933001 | S1 - 33     | 62   |
|           | S2 - 33     | 66   |
| S21934001 | S1 - 35     | 62   |
|           | S2 - 35     | 66   |
| S21935001 | S1 - 37     | 62   |
|           | S2 - 37     | 66   |
| S21937001 | S1 - 41     | 62   |
|           | S2 - 41     | 66   |
| S21938001 | S1 - 43     | 62   |
|           | S2 - 43     | 66   |
| S21940101 | S1 - 51     | 62   |
|           | S2 - 51     | 66   |
| S21941001 | Q - 3       | 58   |
| S21942001 | Z2 - 26-2   | 86   |
| S21943001 | Z1 - 110    | 84   |
| S21946101 | U - 1-1-1   | 70   |
| S21947001 | U - 1-1-1   | 70   |
| S21948101 | U - 1-1-2   | 70   |
| S21949101 | U - 1-1-2-1 | 70   |
| S21950009 | U - 1-1-3   | 70   |
| S21951001 | U - 1-1-3-1 | 70   |
| S21952101 | U - 1-2     | 70   |
| S21953001 | U - 1-1-11  | 70   |
| S21954001 | U - 1-1-15  | 70   |
| S21955001 | U - 1-1-16  | 70   |
| S21960001 | A4 - 16-3   | 12   |
| S21963001 | K2 - 140    | 44   |
| S21964001 | T - 1       | 68   |
| S21965001 | T - 4       | 68   |
| S21966001 | T - 6       | 68   |
| S21967001 | T - 8       | 68   |
| S21968001 | T - 9       | 68   |
| S21969001 | T - 13      | 68   |
| S21970001 | T - 15      | 68   |
| S21971001 | T - 17      | 68   |
| S21972001 | T - 19      | 68   |
| S21974001 | T - 21      | 68   |
| S21976001 | T - 22      | 68   |
| S21977001 | T - 24      | 68   |
| S21978000 | T - 28      | 68   |
| S21979001 | T - 29      | 68   |
| S21980001 | T - 30      | 68   |
| S21981001 | T - 32      | 68   |
| S21982101 | T - 34      | 68   |
| S21983001 | T - 35      | 68   |
| S21984001 | T - 36      | 68   |
| S21985001 | T - 37      | 68   |
| S21986001 | T - 39      | 68   |
| S21987001 | T - 41      | 68   |
| S21988001 | T - 43      | 68   |
| S23323001 | N1 - 15     | 52   |

| CODE      | REF.NO.    | Page |
|-----------|------------|------|
| S23647000 | X2 - 40-22 | 80   |
| S23660000 | R - 24     | 58   |
| S23671000 | A3 - 163-2 | 8    |
|           | A4 - 240-2 | 10   |
| S24021000 | R - 28     | 58   |
| S25818002 | E1 - 80    | 26   |
| S28007001 | A1 - 35    | 2    |
| S28008000 | A1 - 36    | 2    |
| S28011000 | A1 - 40    | 2    |
| S28012001 | A1 - 43    | 2    |
| S28014000 | A1 - 45    | 2    |
| S28021001 | A2 - 52-3  | 6    |
| S28022001 | A4 - 52-4  | 10   |
| S28024001 | A2 - 52-6  | 6    |
|           | A2 - 52-6  | 6    |
|           | A2 - 52-6  | 6    |
|           | A4 - 52-6  | 10   |
| S28027001 | A1 - 55-1  | 2    |
| S28029001 | A4 - 55-3  | 10   |
| S28030001 | A2 - 55-4  | 6    |
|           | A4 - 55-4  | 10   |
| S28031001 | A1 - 56    | 2    |
| S28032001 | A1 - 59    | 2    |
| S28033000 | A1 - 64    | 2    |
| S28034101 | A1 - 72    | 2    |
| S28035001 | A1 - 74    | 2    |
| S28036001 | A1 - 78    | 2    |
| S28037000 | A1 - 79    | 2    |
| S28038001 | A1 - 81-1  | 2    |
| S28039000 | A1 - 82    | 2    |
| S28040000 | A1 - 83    | 2    |
| S28041001 | A1 - 88-1  | 4    |
| S28042001 | A2 - 88-2  | 6    |
|           | A4 - 88-2  | 10   |
| S28043009 | A1 - 90    | 4    |
| S28044009 | A1 - 91    | 4    |
| S28045000 | A1 - 100   | 4    |
| S28046000 | A1 - 101   | 4    |
| S28052001 | A2 - 128   | 6    |
|           | A2 - 128   | 6    |
| S28053001 | A2 - 129   | 6    |
|           | A2 - 129   | 6    |
| S28054001 | A2 - 132   | 6    |
|           | A2 - 200   | 6    |
| S28055001 | A2 - 133   | 6    |
|           | A2 - 201   | 6    |
| S28056001 | A2 - 135   | 6    |
|           | A2 - 135   | 6    |
|           | A2 - 203   | 6    |
| S28059101 | A2 - 206   | 6    |
|           | A4 - 226   | 10   |
| S28060001 | A2 - 68-3  | 6    |
| S28061001 | N2 - 142   | 54   |
| S28063001 | B - 35-1   | 14   |
| S28064001 | B - 35-1-1 | 14   |
|           | B - 35-2-1 | 16   |
|           | B - 35-3-1 | 16   |
|           | B - 35-4-1 | 16   |
|           | B - 35-5-1 | 16   |
| S28065001 | B - 35-2   | 16   |
| S28066001 | B - 35-3   | 16   |
| S28068001 | B - 11-1   | 14   |
| S28069009 | B - 1      | 14   |
| S28070009 | B - 1-1    | 14   |
| S28075001 | B - 38     | 14   |
| S28087001 | B - 48     | 14   |
| S28088001 | B - 50     | 14   |
| S28090001 | B - 52     | 14   |

| CODE      | REF.NO.     | Page |
|-----------|-------------|------|
| S28090001 | B - 62      | 14   |
| S28091001 | B - 54      | 14   |
| S28092001 | B - 56      | 14   |
| S28094001 | B - 58      | 14   |
| S28095001 | B - 60      | 14   |
| S28096000 | B - 51      | 14   |
|           | B - 61      | 14   |
| S28097001 | B - 64      | 14   |
| S28099000 | D - 4-1     | 22   |
| S28100000 | D - 4-2     | 22   |
| S28101000 | D - 6       | 22   |
| S28104000 | D - 9       | 22   |
| S28105001 | C2 - 36-1   | 22   |
|           | Z2 - 62-1   | 86   |
| S28106001 | C2 - 36-2   | 22   |
| S28107101 | C2 - 36-3   | 20   |
|           | Z2 - 62-2   | 86   |
| S28108101 | C2 - 36-4   | 20   |
| S28131001 | C2 - 40-6-1 | 22   |
| S28156001 | A1 - 85     | 4    |
| S28157000 | A1 - 58     | 2    |
| S28159001 | E1 - 1      | 24   |
| S28160001 | E1 - 1-1    | 24   |
| S28161001 | E1 - 1-1-3  | 24   |
| S28163001 | E1 - 1-1-1  | 24   |
| S28164001 | E1 - 1-1-2  | 24   |
| S28165001 | G - 27-2    | 32   |
|           | E1 - 1-2    | 24   |
| S28166001 | E1 - 4      | 24   |
| S28167001 | E1 - 7      | 24   |
| S28168001 | E1 - 8      | 24   |
| S28170001 | E1 - 9      | 24   |
| S28171001 | E1 - 11     | 24   |
| S28172001 | E1 - 13     | 24   |
| S28173000 | E1 - 14     | 24   |
| S28174001 | E1 - 16     | 24   |
| S28175000 | E1 - 17     | 24   |
| S28176001 | E1 - 18     | 24   |
| S28177001 | E1 - 20     | 24   |
| S28179001 | E1 - 22     | 24   |
| S28180001 | E1 - 23     | 24   |
| S28181001 | E1 - 26     | 24   |
| S28182001 | E1 - 28     | 24   |
| S28183001 | E1 - 30     | 24   |
| S28184000 | G - 5       | 32   |
|           | E1 - 31     | 24   |
| S28185000 | E1 - 32     | 24   |
| S28186001 | E1 - 35     | 24   |
|           | E1 - 40     | 24   |
|           | E1 - 50-2   | 24   |
|           | E1 - 85-3   | 26   |
| S28188001 | E1 - 39     | 24   |
| S28189001 | E1 - 42     | 24   |
| S28190001 | E1 - 44     | 24   |
| S28191001 | E1 - 45     | 24   |
| S28192001 | E1 - 46     | 24   |
| S28193001 | E1 - 47     | 24   |
|           | E1 - 98     | 26   |
| S28194001 | E1 - 49     | 24   |
| S28198001 | E1 - 50-1   | 24   |
| S28199001 | E1 - 50-4   | 26   |
| S28200001 | E1 - 55     | 26   |
| S28201001 | E1 - 56     | 26   |
| S28202001 | E1 - 57     | 26   |
| S28203001 | E1 - 60     | 26   |
| S28204001 | E1 - 62     | 26   |
| S28205001 | E1 - 64     | 26   |
| S28206000 | E1 - 65     | 26   |

| CODE      | REF.NO.      | Page |
|-----------|--------------|------|
| S28207000 | E1 - 66      | 26   |
| S28208001 | E1 - 70      | 26   |
| S28209001 | E1 - 72      | 26   |
| S28210001 | E1 - 74      | 26   |
| S28211001 | E1 - 85      | 26   |
| S28212001 | E1 - 85-1    | 26   |
| S28213001 | E1 - 85-2    | 26   |
| S28214001 | E1 - 88-1    | 26   |
| S28215001 | E1 - 88-2    | 26   |
| S28216000 | E1 - 92      | 26   |
| S28217000 | E1 - 93      | 26   |
| S28218001 | E1 - 94      | 26   |
| S28219001 | E2 - 100-1   | 28   |
| S28220001 | E2 - 100-1-1 | 28   |
| S28221000 | E2 - 100-1-2 | 28   |
| S28222000 | E2 - 100-1-3 | 28   |
| S28223000 | E2 - 101     | 28   |
| S28224000 | E2 - 103     | 28   |
| S28225001 | E2 - 100-2   | 28   |
| S28226001 | E2 - 105     | 28   |
| S28227001 | E2 - 107     | 28   |
| S28228001 | E2 - 109     | 28   |
| S28229000 | E2 - 111     | 28   |
| S28231000 | E2 - 120     | 28   |
|           | N2 - 112     | 54   |
| S28232001 | E2 - 113     | 28   |
|           | E2 - 122     | 28   |
| S28233001 | E2 - 114     | 28   |
| S28234000 | E2 - 118     | 28   |
| S28235000 | E2 - 119     | 28   |
| S28236001 | E2 - 127     | 28   |
| S28248001 | E1 - 75      | 26   |
| S28249001 | E1 - 19      | 24   |
| S28250001 | M - 6        | 48   |
| S28252000 | M - 6-2      | 48   |
| S28253001 | M - 11       | 48   |
| S28254001 | M - 28       | 48   |
| S28256001 | M - 29       | 48   |
| S28260001 | M - 44       | 48   |
| S28261001 | M - 46       | 50   |
| S28263001 | M - 52       | 50   |
| S28264001 | M - 53       | 50   |
| S28265001 | M - 66       | 50   |
| S28266001 | M - 68       | 50   |
| S28267001 | M - 70       | 50   |
| S28268001 | M - 71       | 50   |
| S28269001 | M - 75       | 50   |
| S28270001 | M - 80       | 50   |
| S28271001 | M - 83-1     | 50   |
| S28272001 | M - 83-2     | 50   |
| S28273001 | M - 90       | 50   |
| S28274001 | M - 93       | 50   |
| S28275001 | M - 95       | 50   |
| S28276000 | M - 100-1    | 50   |
| S28277000 | M - 100-2    | 50   |
| S28278000 | M - 100-3    | 50   |
| S28279000 | M - 102-1    | 50   |
| S28282000 | M - 102-2    | 50   |
| S28283000 | M - 102-3    | 50   |
| S28287001 | N1 - 1       | 52   |
| S28289000 | N1 - 1-1     | 52   |
| S28290000 | N1 - 1-2     | 52   |
| S28292001 | N1 - 6       | 52   |
| S28293000 | N1 - 7       | 52   |
| S28295001 | N1 - 10      | 52   |
| S28297001 | N1 - 12      | 52   |
| S28298001 | N1 - 14      | 52   |
| S28299000 | N1 - 16      | 52   |

| CODE      | REF.NO.    | Page |
|-----------|------------|------|
| S28300001 | N1 - 18    | 52   |
| S28302001 | N1 - 20    | 52   |
| S28305001 | N1 - 22    | 52   |
| S28306001 | N1 - 27    | 52   |
|           | N2 - 130   | 54   |
| S28307001 | N1 - 29    | 52   |
| S28308001 | N1 - 31    | 52   |
| S28310001 | N1 - 35    | 52   |
| S28311001 | N1 - 36    | 52   |
|           | N2 - 135   | 54   |
| S28312001 | N1 - 38    | 52   |
| S28313001 | N1 - 39    | 52   |
| S28314000 | N1 - 41    | 52   |
| S28315001 | N1 - 42    | 52   |
| S28316001 | N1 - 44    | 52   |
| S28317001 | N1 - 47    | 52   |
| S28318001 | N1 - 48    | 52   |
|           | S1 - 1-33  | 60   |
|           | S2 - 1-33  | 64   |
| S28319001 | N1 - 50    | 52   |
| S28320001 | N1 - 51    | 52   |
| S28321001 | N1 - 53    | 52   |
| S28322001 | N1 - 55    | 52   |
| S28323001 | N1 - 58    | 52   |
| S28324001 | N1 - 60    | 52   |
| S28332001 | M - 72     | 50   |
| S28333001 | M - 61     | 50   |
| S28334001 | M - 41     | 48   |
| S28336001 | N2 - 100   | 54   |
| S28338000 | N2 - 100-1 | 54   |
| S28340001 | N2 - 106   | 54   |
| S28341000 | N2 - 110   | 54   |
| S28342000 | N2 - 111   | 54   |
| S28343001 | N2 - 114   | 54   |
| S28344001 | N2 - 119   | 54   |
| S28346001 | N2 - 121   | 54   |
| S28348001 | N2 - 123   | 54   |
| S28349001 | N2 - 125   | 54   |
| S28350001 | N2 - 132   | 54   |
| S28352001 | N2 - 134   | 54   |
| S28353001 | N2 - 108   | 54   |
| S28354001 | N2 - 139   | 54   |
| S28357001 | X3 - 65    | 82   |
| S28363001 | F - 10     | 30   |
| S28364001 | F - 10-1   | 30   |
| S28365001 | F - 10-2   | 30   |
| S28367011 | F - 21     | 30   |
| S28367012 | F - 21     | 30   |
| S28368011 | F - 22     | 30   |
| S28368012 | F - 22     | 30   |
| S28372000 | F - 13     | 30   |
| S28373001 | F - 16     | 30   |
| S28374000 | F - 18     | 30   |
| S28375000 | F - 19     | 30   |
| S28376000 | F - 20     | 30   |
| S28377001 | G - 4      | 32   |
| S28381000 | G - 33-1   | 32   |
| S28383001 | G - 17     | 32   |
| S28384001 | G - 18     | 32   |
| S28385000 | G - 20     | 32   |
| S28386001 | G - 21     | 32   |
| S28387001 | G - 22     | 32   |
| S28389001 | G - 25     | 32   |
| S28390001 | G - 27-1   | 32   |
| S28391001 | G - 27-1-1 | 32   |
| S28393001 | G - 27-1-2 | 32   |
| S28394001 | G - 30     | 32   |
| S28396001 | G - 36     | 32   |

| CODE      | REF.NO.    | Page |
|-----------|------------|------|
| S28397101 | H - 1      | 34   |
| S28398001 | H - 1-4    | 34   |
| S28400100 | H - 1-6    | 34   |
| S28401001 | H - 4      | 34   |
| S28403001 | H - 32     | 34   |
| S28405001 | H - 27     | 34   |
| S28406001 | H - 35     | 34   |
| S28409001 | H - 37     | 34   |
| S28411001 | H - 40     | 34   |
| S28415000 | H - 52     | 34   |
| S28416001 | H - 54     | 34   |
| S28417001 | K1 - 99    | 38   |
|           | K2 - 99    | 44   |
| S28420001 | K1 - 101   | 38   |
|           | K2 - 101   | 44   |
| S28421000 | K1 - 103   | 40   |
|           | K2 - 103   | 44   |
| S28422000 | K1 - 104   | 40   |
|           | K2 - 104   | 44   |
| S28423000 | K1 - 105   | 40   |
|           | K2 - 105   | 44   |
| S28424001 | K1 - 106   | 40   |
|           | K2 - 106   | 44   |
| S28425001 | K1 - 108   | 40   |
|           | K2 - 108   | 44   |
| S28427001 | K1 - 109   | 40   |
|           | K2 - 109   | 44   |
| S28431001 | K1 - 113-1 | 40   |
|           | K2 - 113-1 | 44   |
| S28434001 | K1 - 113-2 | 40   |
|           | K2 - 113-2 | 44   |
| S28435001 | K1 - 113-5 | 40   |
|           | K2 - 113-5 | 44   |
| S28436001 | K1 - 128   | 40   |
|           | K2 - 128   | 44   |
| S28437001 | K1 - 130   | 40   |
|           | K2 - 130   | 44   |
| S28438001 | K1 - 78    | 38   |
|           | K2 - 78    | 42   |
| S28441001 | Z2 - 37    | 86   |
| S28442001 | Z2 - 38    | 86   |
| S28444001 | Z2 - 53    | 86   |
| S28445001 | Z2 - 56    | 86   |
| S28468001 | V - 2      | 72   |
|           | X1 - 1     | 78   |
| S28469000 | V - 3-2    | 72   |
|           | X1 - 2-2   | 78   |
| S28470000 | V - 3-3    | 72   |
|           | X1 - 2-3   | 78   |
| S28471000 | V - 3-4    | 72   |
|           | X1 - 2-4   | 78   |
| S28472000 | V - 3-5    | 72   |
|           | X1 - 2-5   | 78   |
| S28473001 | X2 - 40    | 80   |
| S28474000 | X2 - 42    | 80   |
| S28476000 | X2 - 53    | 80   |
| S28477000 | X2 - 53-1  | 80   |
| S28478000 | X2 - 53-2  | 80   |
| S28479000 | X2 - 56    | 80   |
| S28480000 | X2 - 56-1  | 80   |
| S28481000 | X2 - 56-2  | 80   |
| S28490001 | S1 - 1-1   | 60   |
|           | S2 - 1-1   | 64   |
| S28492001 | A1 - 52-1  | 2    |
| S28493001 | A3 - 52-2  | 8    |
| S28494001 | A3 - 52-5  | 8    |
| S28495001 | A3 - 55-2  | 8    |
| S28496001 | A3 - 81-2  | 8    |

| CODE      | REF.NO.      | Page |
|-----------|--------------|------|
| S28497001 | A3 - 88-3    | 8    |
| S28500001 | A2 - 140     | 6    |
|           | A2 - 140     | 6    |
|           | A3 - 140     | 8    |
| S28502001 | A3 - 149     | 8    |
| S28503000 | A3 - 152     | 8    |
|           | A4 - 228     | 10   |
| S28504000 | A3 - 153     | 8    |
|           | A4 - 229     | 10   |
| S28505001 | A3 - 156     | 8    |
| S28506001 | A3 - 159     | 8    |
| S28507000 | A3 - 162     | 8    |
| S28508000 | A3 - 163     | 8    |
|           | A4 - 240     | 10   |
| S28509000 | A3 - 163-1   | 8    |
|           | A4 - 240-1   | 10   |
| S28510001 | A3 - 165     | 8    |
| S28512001 | B - 35-4     | 16   |
| S28513001 | B - 35-5     | 16   |
| S28515001 | A3 - 175     | 8    |
| S28516001 | A3 - 176     | 8    |
| S28517001 | A3 - 179     | 8    |
| S28518001 | A3 - 181     | 8    |
| S28519000 | A3 - 184     | 8    |
| S28521001 | A4 - 68-4    | 10   |
| S28523001 | A2 - 208     | 6    |
|           | A4 - 208     | 10   |
| S28525000 | A4 - 222     | 10   |
| S28526001 | A4 - 233     | 10   |
| S28527001 | A4 - 235     | 10   |
| S28528001 | A4 - 236     | 10   |
| S28529001 | A4 - 238     | 10   |
| S28532001 | A4 - 242     | 10   |
| S28533001 | A4 - 242     | 10   |
| S28558001 | C2 - 40-4-1  | 20   |
| S28560001 | C2 - 40-4-12 | 20   |
| S28567001 | C2 - 40-5-1  | 22   |
| S28569001 | C2 - 40-5-12 | 22   |
| S28570001 | C2 - 40-5-14 | 22   |
| S28591001 | J - 26       | 36   |
| S28596001 | V - 1-1      | 72   |
| S28597000 | V - 1-3      | 72   |
| S28598000 | V - 1-3-1    | 72   |
| S28599000 | V - 1-3-2    | 72   |
|           | S2 - 61-2    | 66   |
| S28600001 | V - 1-5      | 72   |
| S28601001 | L - 1        | 46   |
| S28602001 | L - 1-1-1    | 46   |
| S28604001 | L - 2-3      | 46   |
| S28606001 | L - 1-3      | 46   |
| S28609001 | L - 1        | 46   |
| S28610001 | L - 1-1-2    | 46   |
| S28614001 | L - 1        | 46   |
| S28615001 | L - 1-1-3    | 46   |
| S28619001 | L - 2        | 46   |
| S28620001 | L - 2-1-1    | 46   |
| S28622001 | L - 2        | 46   |
| S28623001 | L - 2-1-2    | 46   |
| S28625001 | L - 2        | 46   |
| S28626001 | L - 2-1-3    | 46   |
| S28629001 | P - 1        | 56   |
| S28630001 | P - 3        | 56   |
| S28631001 | P - 5        | 56   |
| S28632001 | P - 6        | 56   |
| S28633001 | P - 8        | 56   |
| S28634001 | P - 10       | 56   |
| S28635001 | P - 12       | 56   |
| S28636001 | P - 15       | 56   |

| CODE      | REF.NO.   | Page |
|-----------|-----------|------|
| S28637000 | P - 17    | 56   |
| S28638001 | P - 20    | 56   |
| S28639001 | P - 23    | 56   |
| S28640000 | P - 24    | 56   |
| S28641001 | P - 26    | 56   |
| S28642001 | P - 28    | 56   |
| S28643001 | P - 30    | 56   |
| S28644001 | S1 - 1-2  | 60   |
|           | S2 - 1-2  | 64   |
| S28645001 | S1 - 1-3  | 60   |
|           | S1 - 1-9  | 60   |
|           | S1 - 1-16 | 60   |
|           | S1 - 7    | 60   |
|           | S2 - 1-3  | 64   |
|           | S2 - 1-9  | 64   |
|           | S2 - 1-16 | 64   |
|           | S2 - 7    | 64   |
| S28646001 | S1 - 1-4  | 60   |
|           | S1 - 1-7  | 60   |
|           | S1 - 1-10 | 60   |
|           | S1 - 1-17 | 60   |
|           | S1 - 8    | 60   |
|           | S2 - 1-4  | 64   |
|           | S2 - 1-7  | 64   |
|           | S2 - 1-10 | 64   |
|           | S2 - 1-17 | 64   |
|           | S2 - 8    | 64   |
| S28647001 | S1 - 1-5  | 60   |
|           | S2 - 1-5  | 64   |
| S28648001 | S1 - 1-6  | 60   |
|           | S2 - 1-6  | 64   |
| S28649000 | S1 - 1-8  | 60   |
|           | S2 - 1-8  | 64   |
| S28650101 | S1 - 1-11 | 60   |
|           | S2 - 1-11 | 64   |
| S28651001 | S1 - 1-13 | 60   |
|           | S2 - 1-13 | 64   |
| S28652001 | S1 - 1-14 | 60   |
|           | S2 - 1-14 | 64   |
| S28653000 | S1 - 1-15 | 60   |
|           | S2 - 1-15 | 64   |
| S28654001 | S1 - 1-18 | 60   |
|           | S2 - 1-18 | 64   |
| S28655001 | S1 - 1-19 | 60   |
|           | S2 - 1-19 | 64   |
| S28656101 | S1 - 1-20 | 60   |
|           | S2 - 1-20 | 64   |
| S28657001 | S1 - 1-21 | 60   |
|           | S2 - 1-21 | 64   |
| S28658001 | S1 - 1-22 | 60   |
|           | S2 - 1-22 | 64   |
| S28659101 | S1 - 1-23 | 60   |
|           | S2 - 1-23 | 64   |
| S28660001 | S1 - 1-24 | 60   |
|           | S2 - 1-24 | 64   |
| S28661001 | S1 - 1-26 | 60   |
|           | S2 - 1-26 | 64   |
| S28662001 | S1 - 1-28 | 60   |
|           | S2 - 1-28 | 64   |
| S28663001 | S1 - 1-31 | 60   |
|           | S2 - 1-31 | 64   |
| S28665001 | S1 - 2    | 60   |
|           | S2 - 2    | 64   |
| S28666001 | S1 - 4    | 60   |
|           | S2 - 4    | 64   |
| S28667001 | S1 - 6    | 60   |
|           | S2 - 6    | 64   |
| S28668001 | S1 - 12   | 60   |

| CODE      | REF.NO.      | Page |
|-----------|--------------|------|
| S28668001 | S2 - 12      | 64   |
| S28669001 | S1 - 51-2    | 62   |
|           | S2 - 51-2    | 66   |
| S28670000 | S2 - 61      | 66   |
| S28671000 | S2 - 61-1    | 66   |
| S28674000 | S2 - 65      | 66   |
| S28675000 | S2 - 66      | 66   |
| S28676000 | S2 - 66-1    | 66   |
| S28677000 | S2 - 68      | 66   |
| S28678001 | S2 - 60      | 66   |
| S28680001 | V - 7-1-1    | 72   |
| S28681001 | V - 1        | 72   |
| S28682001 | V - 7        | 72   |
| S28683001 | V - 7-1      | 72   |
| S28685000 | V - 7-3      | 72   |
|           | X1 - 14      | 78   |
| S28686000 | V - 7-4      | 72   |
| S28687001 | W1 - 1       | 74   |
| S28688001 | W1 - 1-1     | 74   |
| S28689001 | W1 - 1-1-1   | 74   |
|           | W2 - 2-1-1   | 76   |
| S28690001 | W1 - 1-1-3   | 74   |
|           | W2 - 2-1-3   | 76   |
| S28691000 | W1 - 1-1-4   | 74   |
|           | W2 - 2-1-4   | 76   |
| S28692001 | W1 - 1-1-5   | 74   |
|           | W2 - 2-1-5   | 76   |
| S28693000 | W1 - 1-1-7   | 74   |
|           | W1 - 1-2-5   | 74   |
|           | W1 - 1-3-6   | 74   |
|           | W2 - 2-1-7   | 76   |
|           | W2 - 2-2-5   | 76   |
|           | W2 - 2-3-6   | 76   |
| S28694001 | W1 - 1-1-9   | 74   |
| S28695000 | W1 - 1-1-10  | 74   |
| S28696001 | W1 - 1-1-11  | 74   |
| S28697001 | W1 - 1-2     | 74   |
|           | W2 - 2-2     | 76   |
| S28698001 | W1 - 1-2-1   | 74   |
|           | W2 - 2-2-1   | 76   |
| S28699001 | W1 - 1-2-4   | 74   |
|           | W2 - 2-2-4   | 76   |
| S28700001 | W1 - 1-2-8-1 | 74   |
|           | W1 - 1-3-8-1 | 74   |
|           | W2 - 2-2-8-1 | 76   |
|           | W2 - 2-3-8-1 | 76   |
| S28701000 | W1 - 1-2-8-3 | 74   |
|           | W1 - 1-3-8-3 | 74   |
|           | W2 - 2-2-8-3 | 76   |
| S28702001 | W1 - 1-3-1   | 74   |
|           | W2 - 2-3-1   | 76   |
| S28703001 | W1 - 1-3-4   | 74   |
|           | W2 - 2-3-4   | 76   |
| S28704001 | W1 - 1-3-5   | 74   |
|           | W2 - 2-3-5   | 76   |
| S28705001 | W1 - 1-3     | 74   |
| S28706001 | W2 - 2       | 76   |
| S28707001 | W2 - 2-1     | 76   |
| S28708001 | W2 - 2-1-9   | 76   |
| S28709001 | W2 - 2-1-10  | 76   |
| S28710001 | W2 - 2-1-12  | 76   |
| S28711000 | W2 - 2-1-13  | 76   |
| S28712001 | W2 - 2-1-14  | 76   |
| S28714001 | W2 - 2-3     | 76   |
| S28716000 | W2 - 2-3-8-3 | 76   |
| S28720009 | X1 - 16      | 78   |
| S28721009 | X1 - 16-11   | 78   |
| S28722009 | X1 - 16-11-1 | 78   |

| CODE      | REF.NO.      | Page |
|-----------|--------------|------|
| S28726001 | X1 - 10      | 78   |
| S28727000 | X1 - 10-1    | 78   |
| S28730000 | X1 - 15      | 78   |
| S28731001 | X3 - 70      | 82   |
| S28732001 | X3 - 70-1    | 82   |
| S28733001 | X3 - 70-5    | 82   |
| S28734001 | X3 - 70-7    | 82   |
| S28735000 | X3 - 70-9    | 82   |
| S28736000 | X3 - 70-9-1  | 82   |
| S28737001 | X3 - 70-10   | 82   |
| S28738000 | X3 - 70-11   | 82   |
| S28739000 | X3 - 70-11-1 | 82   |
| S28740000 | X3 - 70-13   | 82   |
| S28741000 | X3 - 70-14   | 82   |
| S28742000 | N1 - 63      | 52   |
|           | N2 - 140     | 54   |
|           | X1 - 10-3    | 78   |
|           | X3 - 70-9-2  | 82   |
| S28744000 | R - 26       | 58   |
| S28745001 | X2 - 57      | 80   |
| S28746001 | W1 - 1-2-8   | 74   |
|           | W1 - 1-3-8   | 74   |
|           | W2 - 2-2-8   | 76   |
| S28747001 | W2 - 2-3-8   | 76   |
| S28750001 | D - 4        | 22   |
| S28759001 | S1 - 39      | 62   |
|           | S2 - 39      | 66   |
| S28760001 | S1 - 47      | 62   |
|           | S2 - 47      | 66   |
| S28765001 | A1 - 47-1    | 2    |
| S28766001 | A2 - 47-2    | 6    |
|           | A2 - 47-2    | 6    |
|           | A2 - 47-2    | 6    |
|           | A2 - 47-2    | 6    |
|           | A3 - 47-2    | 8    |
|           | A4 - 47-2    | 10   |
|           | A4 - 47-2    | 10   |
| S28790001 | E1 - 50      | 24   |
| S28793001 | E2 - 100     | 28   |
| S28795001 | G - 27       | 32   |
| S28796001 | K1 - 113     | 40   |
|           | K2 - 113     | 44   |
| S28797101 | S1 - 1       | 60   |
|           | S2 - 1       | 64   |
| S28798001 | C1 - 32-1    | 18   |
| S28800001 | C1 - 32-2    | 18   |
| S28801001 | C1 - 32-3    | 18   |
| S28802001 | A4 - 14-1    | 12   |
| S28803001 | A4 - 14-1-1  | 12   |
|           | A4 - 14-2-1  | 12   |
| S28804001 | A4 - 14-1-2  | 12   |
|           | A4 - 14-2-2  | 12   |
| S28805001 | A4 - 14-2    | 12   |
| S28806000 | A4 - 14-2-3  | 12   |
| S28807001 | A4 - 12-2    | 12   |
| S28809001 | A4 - 23-2    | 12   |
| S28810001 | A4 - 16-2    | 12   |
| S28811001 | A4 - 16-4    | 12   |
| S28812000 | A1 - 75      | 2    |
| S28814001 | A1 - 68-1    | 2    |
| S28815001 | A3 - 68-2    | 8    |
| S28818001 | A3 - 171-2   | 8    |
| S28819001 | A3 - 171-1   | 8    |
| S28820000 | A1 - 49      | 2    |
|           | N2 - 100-2   | 54   |
| S28821000 | U - 1-1-2-5  | 70   |
| S28822001 | A2 - 138     | 6    |
| S28823001 | G - 12       | 32   |

| CODE      | REF.NO.      | Page |
|-----------|--------------|------|
| S28824001 | G - 12-1     | 32   |
| S28825001 | G - 12-2     | 32   |
| S28826001 | G - 14       | 32   |
| S28828001 | G - 15       | 32   |
| S28830001 | Z2 - 27      | 86   |
| S28831001 | A2 - 211     | 6    |
|           | A4 - 211     | 10   |
| S28842001 | G - 6        | 32   |
| S28843001 | E2 - 116     | 28   |
|           | E2 - 123     | 28   |
| S28844001 | E1 - 37      | 24   |
| S28845000 | E1 - 90      | 26   |
| S28846001 | H - 29       | 34   |
| S28848000 | G - 9        | 32   |
| S28849000 | Z2 - 2       | 86   |
| S28850001 | A1 - 105     | 4    |
| S28851000 | H - 47       | 34   |
| S28852000 | H - 49       | 34   |
| S28866001 | A3 - 145     | 8    |
| S28867001 | A4 - 220     | 10   |
| S28869000 | G - 26       | 32   |
| S28885001 | G - 33       | 32   |
| S28887001 | Z1 - 118     | 84   |
| S28888001 | Z1 - 118-1   | 84   |
| S28889001 | Z1 - 118-2   | 84   |
| S28890001 | Z1 - 118-3   | 84   |
| S28891001 | Z1 - 118-3-1 | 84   |
| S28892001 | Z1 - 118-3-2 | 84   |
| S28893001 | Z1 - 118-3-3 | 84   |
| S28894001 | Z1 - 118-3-4 | 84   |
| S28895001 | Z1 - 118-3-5 | 84   |
| S28897001 | R - 20       | 58   |
| S28898001 | R - 21       | 58   |
| S28899001 | R - 23       | 58   |
| S28902000 | R - 27       | 58   |
| S29854009 | Z3 - 90      | 88   |
| S29855009 | Z4 - 91      | 90   |
| S30086001 | B - 17-4     | 14   |
| S30564000 | K1 - 17      | 38   |
|           | K2 - 17      | 42   |
| S30565001 | K1 - 26      | 38   |
|           | K2 - 26      | 42   |
| S30565002 | K1 - 23      | 38   |
|           | K2 - 23      | 42   |
| S30565003 | K1 - 21      | 38   |
|           | K2 - 21      | 42   |
|           | K2 - 25      | 42   |
| S30565004 | K1 - 22      | 38   |
|           | K2 - 22      | 42   |
| S31012001 | C1 - 19      | 18   |
| S31013001 | C1 - 20      | 18   |
| 0A1501406 | Z3 - 90-7-5  | 88   |
|           | Z4 - 91-8-5  | 90   |
|           | Z4 - 91-9-5  | 90   |
| 0A1503006 | Z3 - 90-7-4  | 88   |
|           | Z3 - 90-12-2 | 88   |
|           | Z4 - 91-8-4  | 90   |
|           | Z4 - 91-9-4  | 90   |
|           | Z4 - 91-16-2 | 90   |
| 003400804 | L - 1-2      | 46   |
|           | L - 2-2      | 46   |
| 007402516 | X2 - 40-3    | 80   |
| 014060622 | A1 - 32      | 2    |
|           | A1 - 97      | 4    |
| 014060632 | Z3 - 90-16   | 88   |
|           | Z4 - 91-20   | 90   |
| 014680422 | B - 49       | 14   |
|           | B - 53       | 14   |

| CODE      | REF.NO.      | Page |
|-----------|--------------|------|
| 014680422 | B - 55       | 14   |
|           | B - 56-1     | 14   |
|           | B - 59       | 14   |
|           | B - 63       | 14   |
|           | B - 65       | 14   |
|           | G - 19       | 32   |
|           | G - 37       | 32   |
|           | J - 23       | 36   |
|           | M - 13       | 48   |
|           | M - 67       | 50   |
|           | M - 94       | 50   |
|           | P - 9        | 56   |
|           | P - 16       | 56   |
|           | P - 29       | 56   |
|           | T - 5        | 68   |
|           | T - 12       | 68   |
|           | T - 20       | 68   |
|           | A3 - 169     | 8    |
|           | E1 - 5       | 24   |
|           | E1 - 10      | 24   |
|           | E1 - 36      | 24   |
|           | E1 - 41      | 24   |
|           | E1 - 50-3    | 24   |
|           | E1 - 85-4    | 26   |
|           | K1 - 5       | 38   |
|           | K1 - 71      | 38   |
|           | K1 - 110     | 40   |
|           | K1 - 148     | 40   |
|           | K1 - 152     | 40   |
|           | K2 - 5       | 42   |
|           | K2 - 71      | 42   |
|           | K2 - 110     | 44   |
|           | K2 - 148     | 44   |
|           | K2 - 152     | 44   |
|           | N1 - 13      | 52   |
|           | N1 - 34      | 52   |
|           | N1 - 40      | 52   |
|           | N1 - 43      | 52   |
|           | N1 - 45      | 52   |
|           | N1 - 56      | 52   |
|           | N2 - 109     | 54   |
|           | N2 - 138     | 54   |
|           | W1 - 1-1-12  | 74   |
| 014680622 | G - 27-1-1-1 | 32   |
|           | H - 15       | 34   |
|           | J - 1-1-1    | 36   |
|           | Q - 4        | 58   |
|           | A1 - 63      | 2    |
|           | E1 - 24      | 24   |
| 014710522 | U - 1-1-17   | 70   |
|           | N1 - 30      | 52   |
|           | N2 - 133     | 54   |
| 014760622 | B - 16       | 14   |
|           | B - 19-1     | 14   |
|           | M - 1-1-4    | 48   |
|           | M - 50       | 50   |
|           | P - 4        | 56   |
|           | P - 27       | 56   |
|           | C1 - 26      | 18   |
|           | E1 - 69      | 26   |
|           | E1 - 97      | 26   |
|           | S1 - 27      | 62   |
|           | S2 - 27      | 64   |
| 014770622 | B - 2        | 14   |
|           | B - 5        | 14   |
|           | B - 7        | 14   |
|           | B - 14       | 14   |
|           | F - 8        | 30   |

| CODE      | REF.NO.      | Page |
|-----------|--------------|------|
| 014770622 | F - 11       | 30   |
|           | G - 1        | 32   |
|           | J - 13-1     | 36   |
|           | J - 16       | 36   |
|           | M - 3        | 48   |
|           | M - 54       | 50   |
|           | E1 - 1-1-3-1 | 24   |
|           | E1 - 34      | 24   |
|           | E1 - 50-5    | 26   |
|           | E1 - 59      | 26   |
|           | E1 - 86      | 26   |
|           | K1 - 45-1-1  | 38   |
|           | K1 - 100     | 38   |
|           | K1 - 102     | 40   |
|           | K1 - 108-1   | 40   |
|           | K2 - 45-1-1  | 42   |
|           | K2 - 100     | 44   |
|           | K2 - 102     | 44   |
|           | K2 - 108-1   | 44   |
|           | S1 - 31      | 62   |
|           | S2 - 31      | 64   |
|           | W1 - 1-1-14  | 74   |
|           | W2 - 2-1-11  | 76   |
|           | W2 - 2-1-15  | 76   |
|           | W2 - 2-1-17  | 76   |
| 014780622 | F - 2        | 30   |
|           | G - 23       | 32   |
|           | E2 - 108     | 28   |
|           | X3 - 63-6    | 82   |
| 017681012 | M - 69       | 50   |
|           | M - 82       | 50   |
| 017711612 | C1 - 1       | 18   |
| 017771412 | G - 8        | 32   |
| 017781012 | X3 - 63-4    | 82   |
|           | X3 - 63-10   | 82   |
|           | X3 - 63-13   | 82   |
| 018060822 | H - 28       | 34   |
|           | A1 - 13      | 2    |
|           | W1 - 1-1-16  | 74   |
|           | W1 - 1-2-8-6 | 74   |
|           | W1 - 1-3-8-6 | 74   |
|           | W2 - 2-1-19  | 76   |
|           | W2 - 2-2-8-6 | 76   |
|           | W2 - 2-3-8-6 | 76   |
| 018061022 | M - 91       | 50   |
|           | E1 - 73      | 26   |
| 018061222 | V - 1-2      | 72   |
| 018061622 | H - 2        | 34   |
|           | M - 17       | 48   |
|           | M - 47       | 50   |
| 018061631 | U - 1-1-7    | 70   |
| 018062022 | G - 10       | 32   |
|           | S1 - 23      | 62   |
|           | S2 - 23      | 64   |
| 018063022 | M - 7        | 48   |
| 018081622 | A1 - 102     | 4    |
|           | E1 - 37-1    | 24   |
| 018082022 | W1 - 1-1-6   | 74   |
|           | W1 - 1-2-6   | 74   |
|           | W2 - 2-1-6   | 76   |
|           | W2 - 2-2-6   | 76   |
| 018082522 | W1 - 1-1-8   | 74   |
|           | W2 - 2-1-8   | 76   |
| 018300622 | T - 31       | 68   |
| 018400832 | U - 1-1-4    | 70   |
| 018401422 | F - 22-1     | 30   |
|           | F - 22-1     | 30   |
|           | T - 25       | 68   |



| CODE      | REF.NO.      | Page |
|-----------|--------------|------|
| 018401422 | K1 - 45-2-1  | 38   |
|           | K2 - 45-2-1  | 42   |
|           | N1 - 32      | 52   |
| 018501022 | T - 16       | 68   |
|           | A4 - 239     | 10   |
|           | N1 - 2       | 52   |
| 018501222 | S1 - 24      | 62   |
| 018501422 | N2 - 102     | 54   |
| 018502522 | N1 - 3       | 52   |
| 018503022 | N2 - 101     | 54   |
| 018505022 | V - 1-4      | 72   |
| 018680522 | P - 11       | 56   |
|           | P - 14       | 56   |
| 018680822 | T - 18       | 68   |
|           | A2 - 141     | 6    |
|           | A2 - 141     | 6    |
|           | A2 - 209     | 6    |
|           | A3 - 141     | 8    |
|           | A4 - 209     | 10   |
|           | X3 - 70-6    | 82   |
| 018681022 | B - 36-1     | 14   |
|           | B - 36-2     | 16   |
|           | R - 5        | 58   |
|           | R - 22       | 58   |
|           | N2 - 115     | 54   |
|           | X3 - 70-8    | 82   |
| 018681232 | A1 - 48      | 2    |
| 018771432 | F - 6        | 30   |
|           | G - 13       | 32   |
|           | J - 5        | 36   |
|           | M - 2-1      | 48   |
|           | C1 - 10      | 18   |
|           | E1 - 43      | 24   |
|           | E1 - 49-1    | 24   |
|           | E1 - 63      | 26   |
|           | K1 - 47      | 38   |
|           | K1 - 55      | 38   |
|           | K2 - 47      | 42   |
|           | K2 - 55      | 42   |
| 021060106 | Z2 - 41      | 86   |
| 021060306 | X2 - 40-10   | 80   |
|           | X2 - 40-19   | 80   |
| 021080106 | U - 1-3      | 70   |
|           | Z2 - 29      | 86   |
| 021080302 | U - 1-1-2-3  | 70   |
|           | U - 1-1-10   | 70   |
|           | U - 1-7      | 70   |
|           | V - 1-6      | 72   |
|           | S1 - 20-4    | 60   |
|           | S2 - 64      | 66   |
| 021400102 | T - 27       | 68   |
| 021400106 | X2 - 40-5    | 80   |
|           | Z1 - 23      | 84   |
| 021400164 | X1 - 16-10   | 78   |
| 021400206 | X2 - 40-7    | 80   |
| 021500106 | A3 - 160     | 8    |
|           | Z1 - 115     | 84   |
|           | Z3 - 90-4-2  | 88   |
|           | Z3 - 90-7-3  | 88   |
|           | Z3 - 90-12-3 | 88   |
|           | Z4 - 91-4-2  | 90   |
|           | Z4 - 91-8-3  | 90   |
|           | Z4 - 91-9-3  | 90   |
|           | Z4 - 91-13-3 | 90   |
|           | Z4 - 91-16-3 | 90   |
| 021660102 | C2 - 40-4-8  | 20   |
|           | C2 - 40-5-8  | 22   |
| 021710202 | P - 2        | 56   |

| CODE      | REF.NO.      | Page |
|-----------|--------------|------|
| 021710202 | P - 22       | 56   |
| 025030232 | A4 - 14-1-5  | 12   |
|           | A4 - 14-2-5  | 12   |
| 025030335 | Q - 1-4      | 58   |
| 025040233 | X1 - 16-8    | 78   |
| 025040236 | A3 - 164     | 8    |
|           | X2 - 40-4    | 80   |
|           | X2 - 40-16   | 80   |
| 025050132 | A1 - 61      | 2    |
| 025050232 | A4 - 14-1-8  | 12   |
|           | A4 - 14-2-8  | 12   |
| 025050236 | A3 - 161     | 8    |
|           | Z1 - 113     | 84   |
| 025060236 | Z2 - 39      | 86   |
| 025060332 | W1 - 1-2-8-5 | 74   |
|           | W1 - 1-3-8-5 | 74   |
|           | W2 - 2-1-18  | 76   |
|           | W2 - 2-2-8-5 | 76   |
|           | W2 - 2-3-8-5 | 76   |
| 025080232 | U - 1-1-2-4  | 70   |
|           | S1 - 20-6    | 60   |
|           | W1 - 1-2-7   | 74   |
|           | W1 - 1-3-7   | 74   |
|           | W2 - 2-2-7   | 76   |
|           | W2 - 2-3-7   | 76   |
| 025080236 | U - 1-5      | 70   |
|           | Z2 - 31      | 86   |
| 025350332 | H - 1-2      | 34   |
|           | P - 18       | 56   |
| 025630132 | S1 - 1-30    | 60   |
|           | S2 - 1-30    | 64   |
| 025680133 | A3 - 178     | 8    |
| 025710232 | P - 21       | 56   |
|           | P - 25       | 56   |
| 025750132 | Z2 - 55      | 86   |
| 028040243 | X1 - 16-9    | 78   |
| 028050246 | A4 - 14-1-7  | 12   |
|           | A4 - 14-2-7  | 12   |
|           | Z1 - 114     | 84   |
|           | Z3 - 90-7-2  | 88   |
|           | Z4 - 91-8-2  | 90   |
|           | Z4 - 91-9-2  | 90   |
| 028060242 | Z2 - 40      | 86   |
| 028080242 | U - 1-4      | 70   |
|           | Z2 - 30      | 86   |
| 031311302 | X1 - 11      | 78   |
|           | X1 - 22      | 78   |
|           | X2 - 46      | 80   |
|           | X2 - 58      | 80   |
| 031452206 | W1 - 1-1-2   | 74   |
|           | W1 - 1-2-2   | 74   |
|           | W1 - 1-3-2   | 74   |
|           | W2 - 2-1-2   | 76   |
|           | W2 - 2-2-2   | 76   |
|           | W2 - 2-3-2   | 76   |
|           | Z4 - 91-13-4 | 90   |
| 032422505 | V - 7-2      | 72   |
|           | X3 - 64      | 82   |
|           | X3 - 70-12   | 82   |
| 034422503 | X1 - 17      | 78   |
| 047140850 | N1 - 31-1    | 52   |
|           | N2 - 132-1   | 54   |
| 047200642 | D - 1-2      | 22   |
|           | K1 - 125     | 40   |
|           | K2 - 125     | 44   |
| 047400842 | M - 65       | 50   |
|           | E1 - 49-2    | 24   |
| 047402042 | G - 22-1     | 32   |

| CODE      | REF.NO.      | Page |
|-----------|--------------|------|
| 047501242 | E1 - 71      | 26   |
| 048015346 | C2 - 40-4-5  | 20   |
|           | C2 - 40-5-5  | 22   |
| 048020342 | C2 - 40-1-5  | 20   |
|           | C2 - 40-2-5  | 20   |
|           | C2 - 40-3-5  | 20   |
|           | C2 - 40-6-5  | 22   |
| 048030342 | K1 - 145     | 40   |
|           | K2 - 145     | 44   |
|           | N1 - 52      | 52   |
| 048040342 | U - 1-1-13   | 70   |
|           | A1 - 60      | 2    |
| 048050342 | T - 3        | 68   |
| 048080342 | W1 - 1-2-8-2 | 74   |
|           | W1 - 1-3-8-2 | 74   |
|           | W2 - 2-2-8-2 | 76   |
|           | W2 - 2-3-8-2 | 76   |
| 048090142 | M - 30       | 48   |
| 048090342 | K1 - 111     | 40   |
|           | K2 - 111     | 44   |
| 048180242 | H - 50       | 34   |
| 048240242 | H - 48       | 34   |
| 048470242 | F - 17       | 30   |
| 060400616 | X2 - 40-15   | 80   |
| 060630412 | C2 - 40-4-11 | 20   |
|           | C2 - 40-5-11 | 22   |
|           | E2 - 121     | 28   |
|           | N2 - 113     | 54   |
| 060670512 | R - 15       | 58   |
|           | A4 - 14-1-10 | 12   |
|           | A4 - 14-2-10 | 12   |
|           | X2 - 50-6    | 80   |
| 060670812 | B - 39       | 14   |
| 060680512 | T - 42       | 68   |
|           | K1 - 143     | 40   |
|           | K2 - 141     | 44   |
|           | K2 - 143     | 44   |
|           | S1 - 49      | 62   |
|           | S2 - 49      | 66   |
| 060680712 | A3 - 154     | 8    |
|           | A4 - 15      | 12   |
|           | A4 - 24-2    | 12   |
|           | A4 - 230     | 10   |
|           | C1 - 3       | 18   |
|           | K1 - 41      | 38   |
|           | K2 - 41      | 42   |
|           | K2 - 62      | 42   |
|           | K2 - 80      | 44   |
|           | N2 - 141     | 54   |
|           | S1 - 3       | 60   |
|           | S1 - 34      | 62   |
|           | S1 - 38      | 62   |
|           | S1 - 40      | 62   |
|           | S2 - 3       | 64   |
|           | S2 - 34      | 66   |
|           | S2 - 38      | 66   |
|           | S2 - 40      | 66   |
|           | Z2 - 44      | 86   |
|           | Z2 - 44      | 86   |
| 060681212 | A1 - 44      | 2    |
| 062020805 | S1 - 36      | 62   |
|           | S2 - 36      | 66   |
| 062300612 | N1 - 23      | 52   |
|           | N2 - 124     | 54   |
| 062301616 | S1 - 42      | 62   |
|           | S2 - 42      | 66   |
| 062303012 | S2 - 67      | 66   |
| 062350616 | E1 - 81      | 26   |

| CODE      | REF.NO.      | Page |
|-----------|--------------|------|
| 062401006 | X1 - 16-7    | 78   |
| 062401406 | Z1 - 24      | 84   |
| 062501006 | Z1 - 112     | 84   |
|           | Z4 - 91-13-2 | 90   |
| 062501406 | Z3 - 90-4-1  | 88   |
|           | Z4 - 91-4-1  | 90   |
| 062630412 | R - 13       | 58   |
|           | T - 33       | 68   |
|           | C2 - 37      | 20   |
|           | C2 - 37      | 20   |
|           | C2 - 37      | 22   |
|           | C2 - 37      | 22   |
| 062630612 | M - 1-5      | 48   |
| 062660512 | T - 38       | 68   |
|           | A4 - 14-1-4  | 12   |
|           | A4 - 14-2-4  | 12   |
|           | C2 - 40-1-7  | 20   |
|           | C2 - 40-2-7  | 20   |
|           | C2 - 40-3-7  | 20   |
|           | C2 - 40-6-7  | 22   |
| 062670412 | L - 1-3-1    | 46   |
|           | L - 2-3-1    | 46   |
|           | A3 - 145-1   | 8    |
|           | A4 - 220-1   | 10   |
|           | C2 - 40-5-15 | 22   |
|           | S1 - 5       | 60   |
|           | S2 - 5       | 64   |
| 062670512 | K1 - 154     | 40   |
|           | K2 - 154     | 44   |
|           | N1 - 61      | 52   |
| 062670612 | B - 22       | 14   |
|           | G - 27-3     | 32   |
|           | H - 6        | 34   |
|           | H - 8        | 34   |
|           | H - 12       | 34   |
|           | H - 18       | 34   |
|           | H - 21       | 34   |
|           | H - 36       | 34   |
|           | P - 19       | 56   |
|           | U - 1-1-3-3  | 70   |
|           | U - 1-1-6    | 70   |
|           | U - 1-1-9    | 70   |
|           | E1 - 1-3     | 24   |
|           | K1 - 69      | 38   |
|           | K1 - 113-3   | 40   |
|           | K1 - 117     | 40   |
|           | K2 - 69      | 42   |
|           | K2 - 113-3   | 44   |
|           | K2 - 117     | 44   |
|           | N2 - 126     | 54   |
| 062670812 | H - 1-3      | 34   |
|           | R - 11       | 58   |
|           | C1 - 33      | 18   |
|           | E1 - 76      | 26   |
| 062671012 | D - 7        | 22   |
|           | G - 33-2     | 32   |
|           | H - 1-8      | 34   |
|           | U - 1-1-3-2  | 70   |
| 062680512 | T - 7        | 68   |
|           | A2 - 207     | 6    |
|           | A4 - 221     | 10   |
|           | A4 - 224     | 10   |
|           | A4 - 227     | 10   |
|           | S1 - 26      | 62   |
|           | S2 - 26      | 64   |
| 062680612 | F - 4        | 30   |
|           | M - 45       | 48   |
|           | T - 23       | 68   |

| CODE      | REF.NO.     | Page |
|-----------|-------------|------|
| 062680612 | A2 - 204    | 6    |
|           | A4 - 237    | 10   |
|           | K1 - 92     | 38   |
|           | K1 - 127    | 40   |
|           | K1 - 129    | 40   |
|           | K2 - 44     | 42   |
|           | K2 - 92     | 44   |
|           | K2 - 127    | 44   |
|           | K2 - 129    | 44   |
| 062680663 | U - 1-1-3-5 | 70   |
|           | S1 - 46     | 62   |
|           | S2 - 46     | 66   |
| 062680712 | R - 17      | 58   |
|           | R - 30      | 58   |
|           | T - 45      | 68   |
|           | A1 - 86     | 4    |
|           | N1 - 49     | 52   |
|           | S1 - 53     | 62   |
|           | S2 - 53     | 66   |
|           | X1 - 21     | 78   |
|           | X2 - 45     | 80   |
| 062680812 | D - 5       | 22   |
|           | H - 41      | 34   |
|           | H - 43      | 34   |
|           | A1 - 37-1   | 2    |
|           | A1 - 76     | 2    |
|           | A3 - 150    | 8    |
|           | A3 - 157    | 8    |
|           | A3 - 177    | 8    |
|           | A3 - 180    | 8    |
|           | A4 - 232    | 10   |
|           | K1 - 2      | 38   |
|           | K1 - 74     | 38   |
|           | K2 - 2      | 42   |
|           | K2 - 74     | 42   |
| 062681012 | J - 27      | 36   |
|           | A1 - 4      | 2    |
|           | A2 - 37-2   | 6    |
|           | A3 - 37-2   | 8    |
|           | A4 - 20     | 12   |
|           | A4 - 37-2   | 10   |
|           | A4 - 37-2   | 10   |
|           | K1 - 7      | 38   |
|           | K1 - 58     | 38   |
|           | K2 - 7      | 42   |
|           | K2 - 58     | 42   |
| 062681212 | K1 - 32     | 38   |
|           | K2 - 32     | 42   |
|           | N1 - 21     | 52   |
|           | N2 - 122    | 54   |
| 062681412 | J - 25      | 36   |
|           | C1 - 29     | 18   |
| 062681612 | A1 - 18-1   | 2    |
|           | A1 - 80     | 2    |
|           | A4 - 18-2   | 12   |
|           | N1 - 54     | 52   |
| 062682012 | M - 55      | 50   |
| 062710612 | L - 1-4     | 46   |
|           | L - 2-4     | 46   |
|           | A1 - 73     | 2    |
|           | A3 - 146    | 8    |
| 062710712 | N1 - 59     | 52   |
| 062710812 | Z2 - 57     | 86   |
|           | Z2 - 59     | 86   |
| 062711012 | B - 10      | 14   |
| 062711212 | L - 1-5     | 46   |
|           | L - 2-5     | 46   |
|           | Q - 2       | 58   |

| CODE      | REF.NO.      | Page |
|-----------|--------------|------|
| 062711212 | A2 - 136     | 6    |
|           | A2 - 136     | 6    |
|           | A3 - 147     | 8    |
| 062711612 | A3 - 166     | 8    |
| 076000600 | Q - 1-3      | 58   |
| 076000800 | W1 - 1-2-8-4 | 74   |
|           | W1 - 1-3-8-4 | 74   |
|           | W2 - 2-2-8-4 | 76   |
|           | W2 - 2-3-8-4 | 76   |
| 081007070 | E1 - 25      | 24   |
| 081007670 | J - 21       | 36   |
| 081008070 | K1 - 112     | 40   |
|           | K2 - 112     | 44   |
| 081012070 | G - 24       | 32   |
|           | E1 - 15      | 24   |
| 081014670 | A1 - 6       | 2    |
| 081044070 | H - 46       | 34   |
| 081046870 | B - 12       | 14   |
| 100064005 | B - 17-4-1   | 14   |
|           | G - 14-1     | 32   |
|           | G - 15-1     | 32   |
|           | C2 - 40-1-2  | 20   |
|           | C2 - 40-2-2  | 20   |
|           | C2 - 40-3-2  | 20   |
|           | C2 - 40-4-3  | 20   |
|           | C2 - 40-5-3  | 22   |
|           | C2 - 40-6-2  | 22   |
| 100105005 | A2 - 112     | 6    |
|           | A4 - 112     | 10   |
|           | E1 - 29      | 24   |
|           | S1 - 29      | 60   |
|           | S2 - 29      | 64   |
| 100257010 | B - 45       | 16   |
| 100360003 | A2 - 34      | 6    |
|           | A2 - 202     | 6    |
| 100463001 | X1 - 16-3    | 78   |
|           | X3 - 63-8    | 82   |
| 100526003 | M - 26-1     | 48   |
| 100644005 | R - 2        | 58   |
|           | E2 - 110     | 28   |
|           | K1 - 157     | 40   |
|           | K2 - 157     | 44   |
| 100645003 | T - 26       | 68   |
|           | A1 - 77      | 2    |
|           | A1 - 87      | 4    |
|           | A2 - 142     | 6    |
|           | A2 - 142     | 6    |
|           | A2 - 205     | 6    |
|           | A2 - 210     | 6    |
|           | A3 - 142     | 8    |
|           | A3 - 151     | 8    |
|           | A3 - 158     | 8    |
|           | A3 - 183     | 8    |
|           | A4 - 210     | 10   |
|           | A4 - 222     | 10   |
|           | A4 - 225     | 10   |
|           | K1 - 59      | 38   |
| 100666002 | Z2 - 54      | 86   |
| 101118001 | V - 4        | 72   |
|           | X1 - 3       | 78   |
|           | X2 - 55      | 80   |
| 101482001 | J - 3        | 36   |
| 101572101 | Z1 - 3       | 84   |
| 101671002 | S1 - 1-32    | 60   |
|           | S2 - 1-32    | 64   |
| 102023005 | N1 - 4       | 52   |
| 102424004 | A1 - 57      | 2    |
|           | Z1 - 49      | 84   |

| CODE      | REF.NO.     | Page |
|-----------|-------------|------|
| 102538002 | M - 101     | 50   |
| 102630001 | B - 23      | 14   |
|           | U - 1-1-14  | 70   |
| 102716004 | N1 - 26     | 52   |
|           | N2 - 129    | 54   |
| 102836004 | T - 40      | 68   |
| 102843004 | A1 - 24-1   | 2    |
| 103810002 | M - 74      | 50   |
|           | M - 76      | 50   |
|           | K1 - 115    | 40   |
|           | K1 - 158    | 40   |
|           | K2 - 115    | 44   |
|           | K2 - 158    | 44   |
| 104449009 | A1 - 27     | 2    |
|           | A1 - 92     | 4    |
| 104450109 | A1 - 28     | 2    |
|           | A1 - 94     | 4    |
| 104464001 | B - 13      | 14   |
| 104521002 | S1 - 30     | 62   |
|           | S2 - 30     | 64   |
| 104830101 | A1 - 99     | 4    |
| 105130001 | A4 - 234    | 10   |
| 105161003 | D - 8       | 22   |
| 105161004 | L - 1-3-2   | 46   |
|           | L - 2-3-2   | 46   |
|           | M - 1-1-3   | 48   |
|           | A3 - 145-2  | 8    |
|           | A4 - 220-2  | 10   |
|           | E1 - 82     | 26   |
|           | K1 - 113-4  | 40   |
|           | K2 - 113-4  | 44   |
| 105234003 | M - 56      | 50   |
|           | M - 79      | 50   |
|           | A1 - 71     | 2    |
|           | A3 - 182    | 8    |
| 105237002 | R - 7       | 58   |
| 105248003 | N1 - 62     | 52   |
|           | X2 - 50-8   | 80   |
| 105288001 | K1 - 113-6  | 40   |
|           | K2 - 113-6  | 44   |
| 105343001 | Z1 - 13     | 84   |
| 105812003 | M - 35      | 48   |
| 106128004 | M - 38      | 48   |
|           | M - 42      | 48   |
| 106129001 | A4 - 14-1-9 | 12   |
|           | A4 - 14-2-9 | 12   |
| 106568003 | S1 - 1-12   | 60   |
|           | S2 - 1-12   | 64   |
| 106588003 | M - 64      | 50   |
| 106629002 | E1 - 27     | 24   |
|           | S1 - 1-34   | 60   |
|           | S2 - 1-34   | 64   |
| 107153001 | B - 18      | 14   |
|           | M - 34      | 48   |
| 107231002 | A1 - 69     | 2    |
| 107272002 | M - 31      | 48   |
|           | A1 - 42     | 2    |
|           | A3 - 172    | 8    |
| 107407003 | M - 84      | 50   |
|           | A1 - 41     | 2    |
| 107453001 | M - 24      | 48   |
| 107779001 | Z1 - 14     | 84   |
| 107780001 | Z2 - 16     | 86   |
| 108549001 | E1 - 67     | 26   |
| 108960002 | N1 - 5      | 52   |
| 109203001 | A1 - 104    | 4    |
| 109239001 | M - 60      | 50   |
| 109763002 | T - 11      | 68   |

| CODE      | REF.NO.     | Page |
|-----------|-------------|------|
| 110072001 | A2 - 130    | 6    |
|           | A2 - 130    | 6    |
| 110087001 | X1 - 16-5   | 78   |
| 110140001 | M - 25      | 48   |
|           | M - 27      | 48   |
|           | S1 - 10     | 60   |
|           | S2 - 10     | 64   |
| 110161006 | G - 32      | 32   |
|           | J - 8       | 36   |
|           | C1 - 16     | 18   |
|           | N2 - 118    | 54   |
| 110167001 | M - 57      | 50   |
|           | V - 1-7     | 72   |
| 110168001 | M - 58      | 50   |
|           | V - 1-8     | 72   |
| 110197001 | J - 22      | 36   |
| 110215002 | L - 1-1-2-2 | 46   |
|           | L - 1-1-3-2 | 46   |
|           | L - 2-1-2-2 | 46   |
|           | L - 2-1-3-2 | 46   |
| 110243001 | N1 - 25     | 52   |
|           | N2 - 128    | 54   |
| 110641002 | A1 - 103    | 4    |
| 110793001 | C1 - 7      | 18   |
| 110813001 | K1 - 12     | 38   |
|           | K2 - 12     | 42   |
| 110832009 | K1 - 14     | 38   |
|           | K2 - 14     | 42   |
| 111032001 | X2 - 50-7   | 80   |
| 112299001 | Z1 - 66     | 84   |
| 112300001 | Z1 - 65     | 84   |
| 112301001 | Z1 - 67     | 84   |
| 112351001 | H - 22      | 34   |
| 112359001 | H - 25      | 34   |
| 112364001 | H - 30      | 34   |
|           | H - 33      | 34   |
|           | H - 38      | 34   |
| 112467002 | H - 1-11    | 34   |
| 112700001 | M - 63      | 50   |
| 112743001 | H - 5       | 34   |
| 112751003 | E2 - 106    | 28   |
| 113431002 | A2 - 137    | 6    |
|           | A2 - 137    | 6    |
|           | Z2 - 58     | 86   |
| 113644001 | M - 1-1-1   | 48   |
| 114967001 | X1 - 16-4   | 78   |
| 115157001 | Z2 - 11     | 86   |
| 115559002 | X3 - 70-4   | 82   |
| 116016001 | Z1 - 25     | 84   |
| 116662003 | Z2 - 60     | 86   |
| 117466000 | Z1 - 18     | 84   |
| 117608001 | M - 8       | 48   |
|           | M - 48      | 50   |
|           | M - 92      | 50   |
| 117671002 | E1 - 33     | 24   |
|           | E1 - 58     | 26   |
| 117934009 | A1 - 22     | 2    |
| 118064001 | Z2 - 9      | 86   |
| 118735002 | T - 10      | 68   |
|           | W1 - 1-1-15 | 74   |
| 118770001 | H - 9       | 34   |
| 118837001 | Z1 - 21     | 84   |
| 118853001 | B - 15      | 14   |
|           | M - 36-1-1  | 48   |
|           | S1 - 28     | 62   |
|           | S2 - 28     | 64   |
| 119712001 | X2 - 40-20  | 80   |
| 121007001 | M - 40      | 48   |



















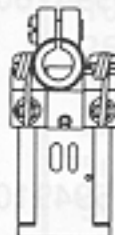

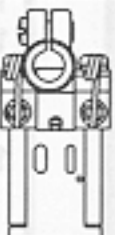
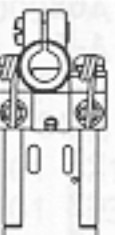
| CODE      | REF.NO.      | Page |
|-----------|--------------|------|
| 122991001 | Z1 - 91      | 84   |
| 126863001 | Z3 - 90-10   | 88   |
|           | Z4 - 91-12   | 90   |
| 138843001 | Z3 - 90-15   | 88   |
|           | Z4 - 91-19   | 90   |
| 140066009 | A1 - 93      | 4    |
| 140092001 | M - 12       | 48   |
| 140407001 | C1 - 22      | 18   |
| 140418000 | E1 - 6       | 24   |
| 140430001 | N1 - 11      | 52   |
| 140678000 | V - 2-3      | 72   |
|           | X1 - 1-3     | 78   |
| 140759000 | Z1 - 46      | 84   |
| 141208001 | C1 - 23      | 18   |
| 141542001 | P - 7        | 56   |
| 141544001 | L - 1-1-1-1  | 46   |
|           | L - 1-1-2-1  | 46   |
|           | L - 1-1-3-1  | 46   |
|           | L - 2-1-1-1  | 46   |
|           | L - 2-1-2-1  | 46   |
|           | L - 2-1-3-1  | 46   |
|           | C2 - 40-4-13 | 20   |
| 141728001 | C1 - 21      | 18   |
| 142026003 | X1 - 16-1    | 78   |
| 142027001 | X1 - 16-2    | 78   |
| 142268001 | U - 1-1-8    | 70   |
| 142274001 | D - 4-4      | 22   |
| 142274009 | A1 - 95      | 4    |
|           | A1 - 98      | 4    |
| 142359001 | H - 3        | 34   |
|           | H - 51       | 34   |
| 142721001 | Z1 - 7       | 84   |
| 142998101 | Z3 - 90-13   | 88   |
| 142999101 | Z4 - 91-17   | 90   |
| 143325001 | C1 - 5       | 18   |
| 143359001 | X2 - 54      | 80   |
| 143522000 | U - 1-1-3-6  | 70   |
| 143566001 | Z1 - 15      | 84   |
| 143602001 | K1 - 42      | 38   |
|           | K2 - 42      | 42   |
| 144075001 | M - 1-1-2    | 48   |
| 144103009 | K1 - 15      | 38   |
|           | K2 - 15      | 42   |
| 144104001 | K1 - 18      | 38   |
|           | K2 - 18      | 42   |
| 144110001 | K1 - 19      | 38   |
|           | K2 - 19      | 42   |
| 144224001 | Z1 - 47      | 84   |
| 144504001 | K2 - 83      | 44   |
| 144505000 | K2 - 84      | 44   |
| 144526001 | K1 - 149     | 40   |
|           | K1 - 155     | 40   |
|           | K2 - 149     | 44   |
|           | K2 - 155     | 44   |
| 144619000 | H - 1-1      | 34   |
| 144622001 | H - 1-5      | 34   |
| 144625009 | X2 - 50-4    | 80   |
| 144875001 | H - 1-9      | 34   |
| 144876001 | H - 1-10     | 34   |
| 145277105 | Z1 - 20      | 84   |
| 145446001 | K1 - 16      | 38   |
|           | K2 - 16      | 42   |
| 145472001 | C1 - 24      | 18   |
| 145480101 | X3 - 70-2    | 82   |
| 145688000 | B - 21       | 14   |
| 145737001 | H - 19       | 34   |
| 146046000 | X1 - 16-11-2 | 78   |
| 146049001 | Z2 - 6       | 86   |

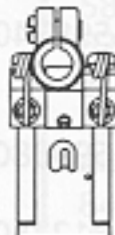
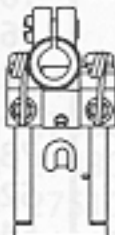
| CODE      | REF.NO.      | Page |
|-----------|--------------|------|
| 146194000 | X1 - 16-11-3 | 78   |
| 146254001 | U - 1-6      | 70   |
| 146354001 | A4 - 233     | 10   |
|           | W1 - 1-2-3   | 74   |
|           | W1 - 1-3-3   | 74   |
|           | W2 - 2-2-3   | 76   |
|           | W2 - 2-3-3   | 76   |
| 146427001 | B - 30-1     | 16   |
|           | B - 30-1     | 16   |
|           | P - 31       | 56   |
|           | C2 - 40-4-6  | 20   |
|           | C2 - 40-5-6  | 22   |
|           | K2 - 87      | 44   |
| 146522101 | C1 - 2       | 18   |
| 146547000 | J - 17       | 36   |
| 146598001 | A1 - 62      | 2    |
| 146695001 | X2 - 40-9    | 80   |
|           | X2 - 40-18   | 80   |
| 146700001 | Z2 - 4       | 86   |
| 146924000 | K1 - 113-1-1 | 40   |
|           | K2 - 113-1-1 | 44   |
| 147246101 | X2 - 50      | 80   |
| 147247009 | X2 - 50-1    | 80   |
| 147248009 | X2 - 50-2    | 80   |
| 147251009 | X2 - 50-3    | 80   |
| 147252000 | X2 - 50-5    | 80   |
| 147402001 | P - 13       | 56   |
|           | A3 - 168     | 8    |
| 147527000 | H - 1-7      | 34   |
| 147528100 | H - 1-12     | 34   |
| 147529000 | H - 1-13     | 34   |
| 147893009 | Z1 - 22      | 84   |
| 147919002 | Z2 - 42      | 86   |
|           | Z2 - 42      | 86   |
| 148084001 | A1 - 38      | 2    |
| 148120000 | M - 6-1      | 48   |
| 148144001 | N1 - 46      | 52   |
| 148186001 | E2 - 115     | 28   |
| 148196000 | J - 11       | 36   |
| 148197000 | J - 12       | 36   |
| 148294001 | M - 21       | 48   |
|           | A1 - 84      | 4    |
| 148559100 | E1 - 84      | 26   |
| 148797001 | X3 - 63-5    | 82   |
| 148798009 | X3 - 63-7    | 82   |
| 148834001 | J - 15-1     | 36   |
|           | J - 18       | 36   |
|           | A3 - 185     | 8    |
|           | N1 - 24      | 52   |
|           | N2 - 127     | 54   |
| 148847001 | G - 31       | 32   |
|           | J - 7        | 36   |
|           | L - 1-6      | 46   |
|           | L - 2-6      | 46   |
|           | M - 81       | 50   |
|           | A3 - 148     | 8    |
|           | N2 - 117     | 54   |
| 148857001 | E1 - 12      | 24   |
|           | E1 - 48      | 24   |
|           | E1 - 99      | 26   |
| 149247001 | Z2 - 26-1    | 86   |
| 149288003 | K1 - 131     | 40   |
|           | K2 - 131     | 44   |
| 149547000 | R - 16       | 58   |
|           | T - 44       | 68   |
| 149604001 | N1 - 20-1    | 52   |
|           | N2 - 121-1   | 54   |
| 149799000 | X1 - 16-12   | 78   |

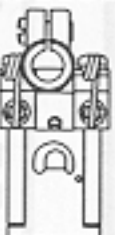
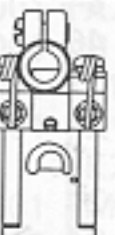
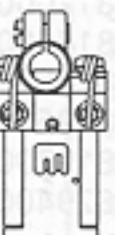





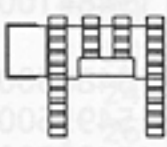
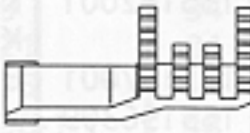



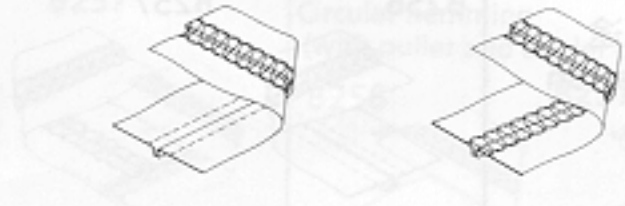







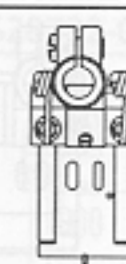
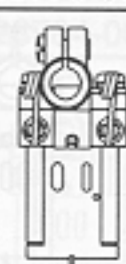
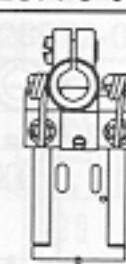

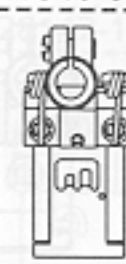
| CODE      | REF.NO.      | Page |
|-----------|--------------|------|
| 150106003 | Z3 - 90-4    | 88   |
|           | Z4 - 91-4    | 90   |
| 150145009 | Z3 - 90-12   | 88   |
|           | Z4 - 91-16   | 90   |
| 150172003 | Z3 - 90-3    | 88   |
|           | Z4 - 91-3    | 90   |
| 150174000 | Z3 - 90-5    | 88   |
|           | Z4 - 91-5    | 90   |
| 150179002 | Z3 - 90-7-1  | 88   |
|           | Z4 - 91-8-1  | 90   |
|           | Z4 - 91-9-1  | 90   |
| 150180001 | Z3 - 90-8    | 88   |
|           | Z4 - 91-10   | 90   |
| 150182000 | Z3 - 90-9    | 88   |
|           | Z4 - 91-11   | 90   |
| 150185009 | Z3 - 90-12-1 | 88   |
|           | Z4 - 91-16-1 | 90   |
| 150188009 | Z4 - 91-13-1 | 90   |
| 150191002 | Z3 - 90-2-2  | 88   |
|           | Z4 - 91-2-2  | 90   |
| 150206002 | Z3 - 90-2-1  | 88   |
|           | Z4 - 91-2-1  | 90   |
| 150604101 | M - 36-3     | 48   |
| 150605001 | M - 36-4     | 48   |
| 150644009 | K2 - 3       | 42   |
| 150645009 | K1 - 4       | 38   |
|           | K2 - 4       | 42   |
| 151090001 | G - 7        | 32   |
| 151429001 | H - 7        | 34   |
| 151439002 | X3 - 70-3    | 82   |
| 151987001 | M - 73       | 50   |
| 152718001 | B - 19-2     | 16   |
|           | N1 - 17      | 52   |
|           | N2 - 107     | 54   |
| 153195001 | A3 - 167     | 8    |
| 153208002 | B - 37-1     | 16   |
|           | B - 37-2     | 16   |
|           | N1 - 37      | 52   |
|           | N2 - 136     | 54   |
| 153269001 | X1 - 10-4    | 78   |
| 153353001 | N1 - 33      | 52   |
|           | N2 - 137     | 54   |
| 153675001 | F - 14       | 30   |
|           | E1 - 89      | 26   |
| 153734001 | F - 3        | 30   |
| 153788001 | W1 - 1-1-13  | 74   |
|           | W2 - 2-1-16  | 76   |
| 154125001 | Z2 - 10      | 86   |
| 154149001 | M - 78       | 50   |
| 154574001 | A1 - 70      | 2    |
| 154596000 | C1 - 27      | 18   |
| 154599000 | A3 - 170     | 8    |
| 154841009 | A1 - 29      | 2    |
|           | A1 - 33      | 4    |
| 154886001 | F - 5        | 30   |
| 154956001 | C1 - 9       | 18   |
| 154957001 | C1 - 11      | 18   |
| 155103001 | C2 - 40-5-13 | 22   |
| 155157001 | E2 - 117     | 28   |
|           | E2 - 124     | 28   |
| 155162001 | K1 - 56      | 38   |
|           | K2 - 56      | 42   |
| 155167001 | E1 - 61      | 26   |
| 155196309 | X3 - 63      | 82   |
| 155197101 | X3 - 63-1    | 82   |
| 155198101 | X3 - 63-2    | 82   |
| 155199101 | X3 - 63-3    | 82   |
| 155201101 | X3 - 63-9    | 82   |

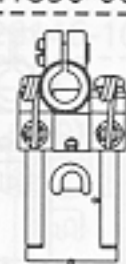







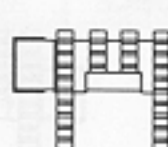
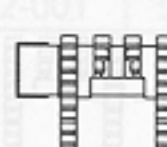
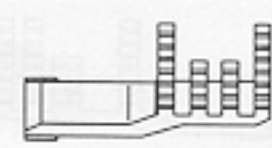
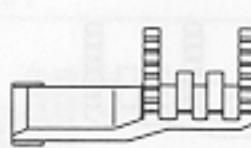

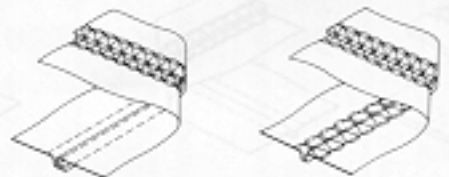

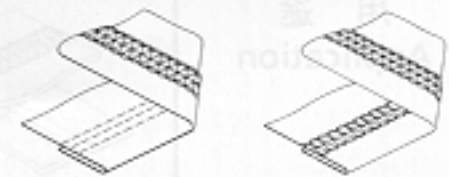





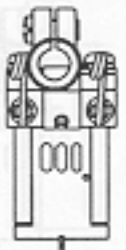

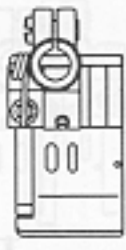
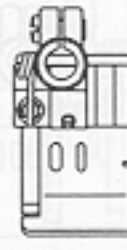
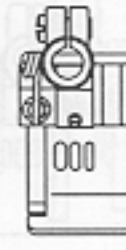
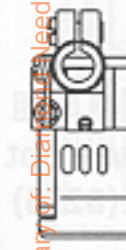
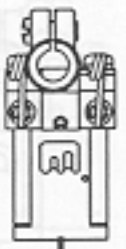

| CODE      | REF.NO.      | Page |
|-----------|--------------|------|
| 155202001 | X3 - 63-11   | 82   |
| 155220000 | C1 - 8       | 18   |
|           | K1 - 48      | 38   |
|           | K2 - 48      | 42   |
| 155318001 | K1 - 116     | 40   |
|           | K2 - 116     | 44   |
| 155510001 | K2 - 85      | 44   |
| 155539000 | C1 - 13      | 18   |
|           | K1 - 53      | 38   |
|           | K2 - 53      | 42   |
| 155559001 | G - 11       | 32   |
| 156112003 | Z3 - 90-1    | 88   |
|           | Z4 - 91-1    | 90   |
| 156217009 | A1 - 96      | 4    |
| 156265001 | M - 23       | 48   |
| 156309001 | Z1 - 12      | 84   |
| 156887001 | A1 - 34      | 4    |
| 156937001 | A4 - 19      | 12   |
| 157840000 | H - 13       | 34   |
| 159093009 | M - 62       | 50   |
| 159150009 | M - 15       | 48   |
|           | A1 - 7       | 2    |
|           | A2 - 30      | 6    |
|           | A3 - 30      | 8    |
|           | A4 - 30      | 10   |
|           | A4 - 30      | 10   |
| 159238001 | M - 77       | 50   |
| 159476000 | H - 23       | 34   |
|           | H - 26       | 34   |
|           | H - 31       | 34   |
|           | H - 34       | 34   |
|           | H - 39       | 34   |
| 159491001 | E1 - 68      | 26   |
|           | E1 - 96      | 26   |
| 159574101 | K1 - 13      | 38   |
|           | K2 - 13      | 42   |
| 159874000 | V - 7-1-3    | 72   |
|           | S2 - 66-4    | 66   |
|           | X3 - 70-11-4 | 82   |
| 159908001 | S1 - 13      | 60   |
|           | S2 - 13      | 64   |
| 181225001 | X2 - 40-17   | 80   |
| 183796201 | U - 1        | 70   |
| 200190001 | X1 - 18      | 78   |
| 211528001 | Q - 1-8      | 58   |
| 211964001 | Z2 - 28      | 86   |
| 215082001 | Q - 1-13     | 58   |
| 215083001 | Q - 1-5      | 58   |
| 216410003 | Q - 1-15     | 58   |
| 216870001 | Q - 1-12     | 58   |
| 219558000 | Q - 1-6-2    | 58   |
| 220077001 | U - 1-1-3-7  | 70   |
| 226391001 | Q - 1-16     | 58   |
| 230100001 | Q - 1-10     | 58   |
| 233193001 | S1 - 50      | 62   |
|           | S2 - 50      | 66   |
| 234141001 | Q - 1-1      | 58   |
| 234143001 | Q - 1-2      | 58   |
| 234144001 | Q - 1-6      | 58   |
| 234145001 | Q - 1-6-1    | 58   |
| 234146001 | Q - 1-7      | 58   |
| 234153001 | Q - 1-11     | 58   |
| 234154002 | Q - 1-14     | 58   |
| 340400001 | H - 53       | 34   |
| 415006002 | S2 - 62      | 66   |
| 525907000 | S1 - 52      | 62   |
|           | S2 - 52      | 66   |
| 575456001 | D - 2        | 22   |



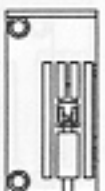





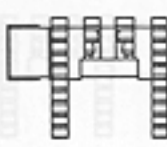
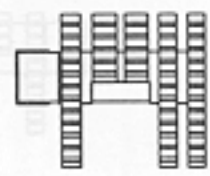
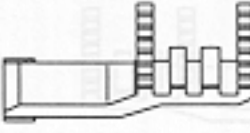
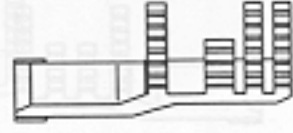

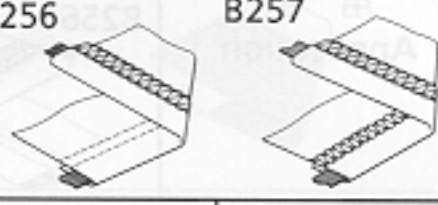

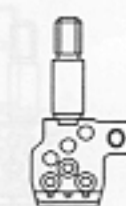







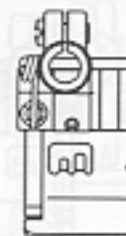

ゲージ部品一覧表 / GAUGE PARTS LIST / LEHRENLISTE /  
LISTE DES PIÈCES D'ECARTEMENT / LISTA DE PIEZAS DE CALIBRADORES

|                                    |   |   |   |   |   |   |
|------------------------------------|---|---|---|---|---|---|
| 機種<br>Model                        | B256<br>B257  | B256<br>B257  | B256<br>B257  | B256<br>B257  | B256<br>B257  | B256<br>B257  |
| 仕様<br>Specifications               | 011-1   | 011-2   | 011-3   | 011-4   | 011-5   | 011-6   |
| 仕様ラベル<br>Label                     | S08678-001  | S08678-002  | S08678-003  | S08678-004  | S08678-005  | S08678-006  |
| 用途<br>Application                  | 地縫用<br>Plain stitching  |   | B256<br>          | B257<br>         |   |   |
| 針数(本)<br>No. of needles            | 2   | 2   | 2   | 2   | 2   | 3   |
| 針幅(mm)<br>Needle spacing           | 3.2   | 4.0   | 4.8   | 5.6   | 6.4   | 4.8   |
| 針止×組<br>Needle clamp<br>assy       | <br>S28770-001 | <br>S28772-001 | <br>S28774-001 | <br>S28776-001 | <br>S28778-001 | <br>S28780-001 |
| 押工組<br>Presser foot assy<br>(B256) | <br>S21832-001 | <br>S21834-001 | <br>S21836-001 | <br>S21838-001 | <br>S21840-001 | <br>S21842-001 |
| 押工組<br>Presser foot assy<br>(B257) | <br>S08779-201 | <br>S08786-201 | <br>S08788-201 | <br>S08790-201 | <br>S08792-201 | <br>S08794-201 |
| 針板<br>Needle plate                 | <br>S08717-001 | <br>S08718-001 | <br>S08719-001 | <br>S08720-001 | <br>S08721-001 | <br>S08722-001 |
| 主送り歯<br>Main feed dog              |   |   |   | <br>S28237-001 |   |   |
| 差動送り歯<br>Differential feed<br>dog  |   |   |   | <br>S28242-001 |   |   |







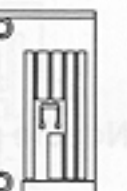
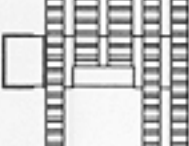
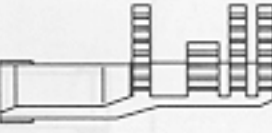



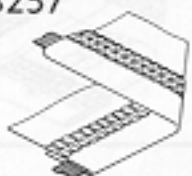

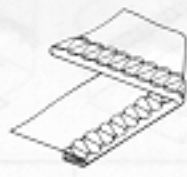



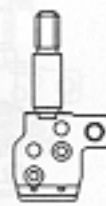
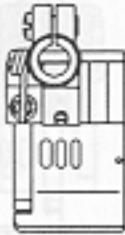

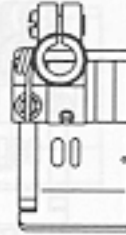
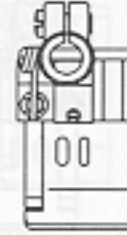
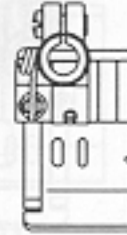

From the library of: Diamond Needle Corp



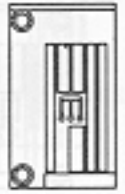



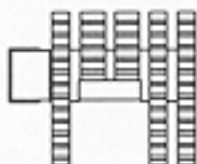



|                                    |   |   |   |   |   |   |
|------------------------------------|---|---|---|---|---|---|
| 機種<br>Model                        | B256<br>B257  | B256<br>B257  | B256<br>B257  | B256<br>B257  | B256<br>B257  | B256<br>B257  |
| 仕様<br>Specifications               | 011-7   | 011-8   | 033-3   | 033-4   | 033-5   | 033-6   |
| 仕様ラベル<br>Label                     | S08678-007  | S08678-008  | S08678-064  | S08678-065  | S08678-066  | S08678-067  |
| 用途<br>Application                  | 地縫用 / Plain stitching<br>B256 B257<br> |   | カバーリング用<br>Covering<br>B256 B257<br> |   |   |   |
| 針数 (本)<br>No. of needles           | 3   | 3   | 2   | 2   | 2   | 3   |
| 針幅 (mm)<br>Needle spacing          | 5.6   | 6.4   | 4.8   | 5.6   | 6.4   | 4.8   |
| 針止×組<br>Needle clamp<br>assy       | <br>S28782-001                        | <br>S28784-001  | <br>S28774-001                      | <br>S28776-001  | <br>S28778-001  | <br>S28780-001  |
| 押工組<br>Presser foot assy<br>(B256) | <br>S21844-001                       | <br>S21846-001 | <br>S21848-001                     | <br>S21850-001 | <br>S21582-001 | <br>S21854-001 |
| 押工組<br>Presser foot assy<br>(B257) | <br>S08796-201                       | <br>S08798-201 | <br>S08828-201                     | <br>S08830-201 | <br>S08832-201 | <br>S08834-201 |
| 針板<br>Needle plate                 | <br>S08723-001                       | <br>S08724-001 | <br>S21823-001                     | <br>S21824-001 | <br>S21825-001 | <br>S21826-001 |
| 主送り歯<br>Main feed dog              | <br>S28237-001                       |   | <br>S28239-001                     |   |   |   |
| 差動送り歯<br>Differential feed<br>dog  | <br>S28242-001                       |   | <br>S28244-001                     |   |   |   |





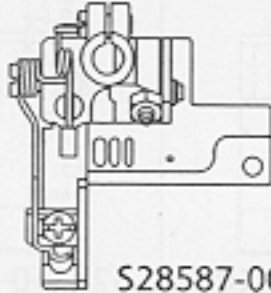
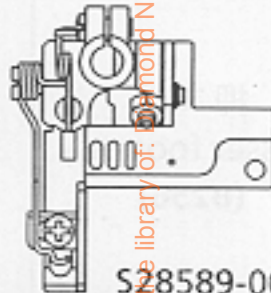
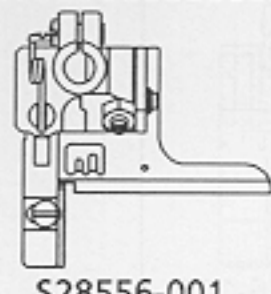
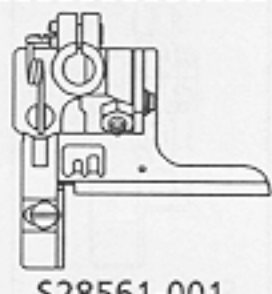
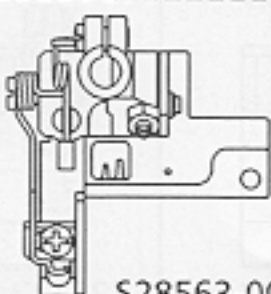
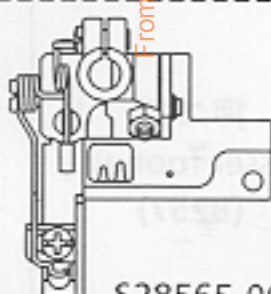



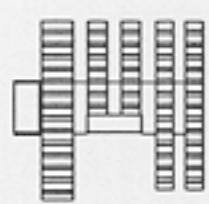
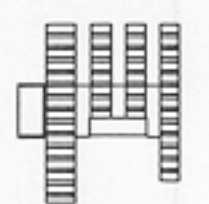
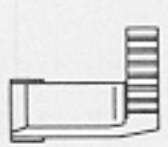
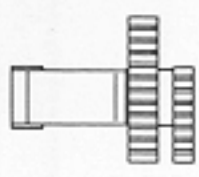



|                                    |  |   |   |   |   |   |
|------------------------------------|--|---|---|---|---|---|
| 機種<br>Model                        | B256<br>B257   | B256<br>B257  | B256<br>B257  | B256<br>B257  | B256<br>B257  | B256<br>B257  |
| 仕様<br>Specifications               | 033-7  | 033-8   | 051-2   | 051-3   | 051-7   | 051-8   |
| 仕様ラベル<br>Label                     | S08678-068   | S08678-069  | S08678-057  | S08678-058  | S08678-062  | S08678-063  |
| 用途<br>Application                  | カバーリング用 / Covering<br>B256 B257<br> |   | ヘム縫用 / Hem stitching<br>B256 B257<br> |   | B256 B257<br>    |   |
| 針数(本)<br>No. of needles            | 3  | 3   | 2   | 2   | 3   | 3   |
| 針幅(mm)<br>Needle spacing           | 5.6  | 6.4   | 4.0   | 4.8   | 5.6   | 6.4   |
| 針止×組<br>Needle clamp<br>assy       | <br>S28782-001                    | <br>S28784-001 | <br>S28772-001                     | <br>S28774-001 | <br>S28782-001 | <br>S28784-001 |
| 押工組<br>Presser foot assy<br>(B256) | <br>S21856-001                    | <br>S21858-001 | <br>S28140-101                     | <br>S28142-101 | <br>S28144-101 | <br>S28146-101 |
| 押工組<br>Presser foot assy<br>(B257) | <br>S08836-201                    | <br>S08838-201 | <br>S28121-101                     | <br>S28123-101 | <br>S28125-101 | <br>S28127-101 |
| 針板<br>Needle plate                 | <br>S21827-001                    | <br>S21828-001 | <br>S28079-001                     | <br>S28080-001 | <br>S28081-001 | <br>S28082-001 |
| 主送り歯<br>Main feed dog              | <br>S28239-001                    |   | <br>S28240-001                     |   |   |   |
| 差動送り歯<br>Differential feed<br>dog  | <br>S28244-001                    |   | <br>S28245-001                     |   |   |   |

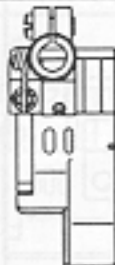
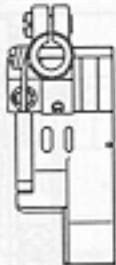
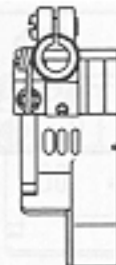
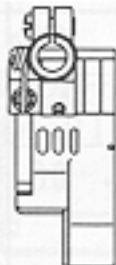

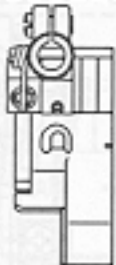
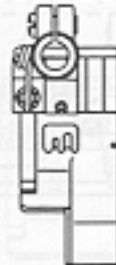





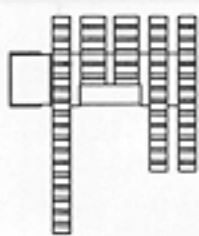
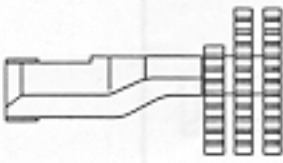

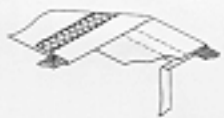





|                                    |  |   |   |   |   |   |
|------------------------------------|--|---|---|---|---|---|
| 機種<br>Model                        | B256<br>B257   | B256<br>B257  | B256<br>B257  | B256<br>B257  | B256<br>B257  | B256<br>B257  |
| 仕様<br>Specifications               | 053-2  | 053-3   | 053-7   | 053-8   | 056-2   | 056-3   |
| 仕様ラベル<br>Label                     | S08678-090   | S08678-091  | S08678-095  | S08678-096  | S08678-070  | S08678-071  |
| 用途<br>Application                  | へム縫用 / Hem stitching<br>B256      B257      B256      B257<br> |   |   |   | ゴム入れへム縫用<br>(プーラ装置・定規開閉装置付)<br>Circular hemming<br>(with puller and binder opener)<br>B256      B257<br> |   |
| 針数(本)<br>No. of needles            | 2  | 2   | 3   | 3   | 2   | 2   |
| 針幅(mm)<br>Needle spacing           | 4.0  | 4.8   | 5.6   | 6.4   | 4.0   | 4.8   |
| 針止×組<br>Needle clamp<br>assy       | <br>S28772-001  | <br>S28774-001 | <br>S28782-001 | <br>S28784-001 | <br>S28772-001   | <br>S28774-001 |
| 押工組<br>Presser foot assy<br>(B256) | <br>S28140-101  | <br>S28142-101 | <br>S28144-101 | <br>S28146-101 | <br>S28579-101   | <br>S28581-101 |
| 押工組<br>Presser foot assy<br>(B257) | <br>S28121-101  | <br>S28123-101 | <br>S28125-101 | <br>S28127-101 | <br>S28548-101   | <br>S28550-101 |
| 針板<br>Needle plate                 | <br>S28079-001  | <br>S28080-001 | <br>S28081-001 | <br>S28082-001 | <br>S28542-001   | <br>S28543-001 |
| 主送り歯<br>Main feed dog              | <br>S28240-001  |   |   |   |   |   |
| 差動送り歯<br>Differential feed<br>dog  | <br>S28245-001  |   |   |   |   |   |

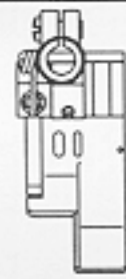
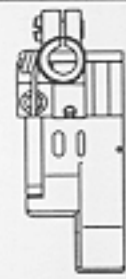

|                                    |   |   |  |   |   |  |
|------------------------------------|---|---|--|---|---|--|
| 機種<br>Model                        | B256<br>B257  | B256<br>B257  | B256<br>B257   | B256<br>B257  | B256<br>B257  |  |
| 仕様<br>Specifications               | 056-7   | 056-8   | 061-1  | 061-2   | 061-3   |  |
| 仕様ラベル<br>Label                     | S08678-072  | S08678-073  | S08678-074   | S08678-075  | S08678-076  |  |
| 用途<br>Application                  | ゴム入れヘム縫用<br>(プーラ装置・定規開閉装置付)<br>Circular hemming<br>(with puller and binder opener)<br>B256  B257  |   | 平ゴムタタキ縫用(プーラ装置付)<br>Elastic hemming (with puller)<br>B256  B257  |   |   |  |
| 針数(本)<br>No. of needles            | 3   | 3   | 2  | 2   | 2   |  |
| 針幅(mm)<br>Needle spacing           | 5.6   | 6.4   | 3.2  | 4.0   | 4.8   |  |
| 針止×組<br>Needle clamp<br>assy       | <br>S28782-001   | <br>S28784-001 | <br>S28770-001  | <br>S28772-001 | <br>S28774-001 |  |
| 押工組<br>Presser foot assy<br>(B256) | <br>S28583-101   | <br>S28585-101 | <br>S28138-101  | <br>S28140-101 | <br>S28142-101 |  |
| 押工組<br>Presser foot assy<br>(B257) | <br>S28552-101   | <br>S28554-101 | <br>S28118-101  | <br>S28121-101 | <br>S28123-101 |  |
| 針板<br>Needle plate                 | <br>S28544-001   | <br>S28545-001 | <br>S28078-001  | <br>S28079-001 | <br>S28080-001 |  |
| 主送り歯<br>Main feed dog              |   |   | <br>S28240-001  |   |   |  |
| 差動送り歯<br>Differential feed<br>dog  |   |   | <br>S28245-001   |   |   |  |

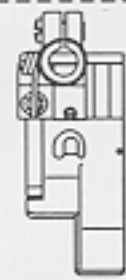
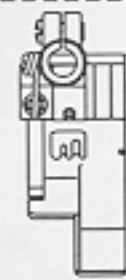
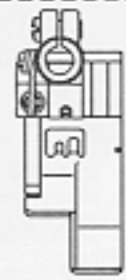
|                                    |  |  |  |   |
|------------------------------------|--|--|--|---|
| 機種<br>Model                        | B257   | B257   | B256<br>B257   | B256<br>B257  |
| 仕様<br>Specifications               | 0V1-7  | 0V1-8  | 0W1-7  | 0W1-8   |
| 仕様ラベル<br>Label                     | S08678-077   | S08678-078   | S08678-079   | S08678-080  |
| 用途<br>Application                  | エンドレススパンゴム付用<br>(プーラ装置・定規開閉装置付)<br>Spun knit elastic loop attaching<br>(with puller and binder opener)<br>B257<br> |  | エンドレス平ゴム付用(プーラ装置・右メス装置付)<br>Wide elastic loop attaching (with puller and right knife)<br>B256<br>B257<br> |   |
| 針数(本)<br>No. of needles            | 3  | 3  | 3  | 3   |
| 針幅(mm)<br>Needle spacing           | 5.6  | 6.4  | 5.6  | 6.4   |
| 針止×組<br>Needle clamp<br>assy       | <br>S28782-001  | <br>S28784-001 | <br>S28782-001  | <br>S28784-001 |
| 押工組<br>Presser foot assy<br>(B256) | —  | —  | <br>S28587-001  | <br>S28589-001 |
| 押工組<br>Presser foot assy<br>(B257) | <br>S28556-001  | <br>S28561-001 | <br>S28563-001  | <br>S28565-001 |
| 針板<br>Needle plate                 | <br>S28546-001  | <br>S28547-001 | <br>S08745-001  | <br>S08746-001 |
| 主送り歯<br>Main feed dog              | <br>S28595-001  |  | <br>S28238-001  |   |
| 差動送り歯<br>Differential feed<br>dog  | <br>S28243-001  |  | <br>S28246-001  |   |

|                                    |  |  |   |   |  |  |
|------------------------------------|--|--|---|---|--|--|
| 機種<br>Model                        | B256<br>B257   | B256<br>B257   | B256<br>B257  | B256<br>B257  |  |  |
| 仕様<br>Specifications               | 0X1-2  | 0X1-3  | 0X1-7   | 0X1-8   |  |  |
| 仕様ラベル<br>Label                     | S08678-081   | S08678-082   | S08678-083  | S08678-084  |  |  |
| 用途<br>Application                  | へム縫用(左メス装置付) / Hem stitching (with left knife)<br>B256                      B257                      B256                      B257<br> |  |   |   |  |  |
| 針数(本)<br>No. of needles            | 2  | 2  | 3   | 3   |  |  |
| 針幅(mm)<br>Needle spacing           | 4.0  | 4.8  | 5.6   | 6.4   |  |  |
| 針止メ組<br>Needle clamp<br>assy       | <br>S28772-001  | <br>S28774-001  | <br>S28782-001 | <br>S28784-001 |  |  |
| 押工組<br>Presser foot assy<br>(B256) | <br>S28148-101  | <br>S28150-101  | <br>S28152-101 | <br>S28154-101 |  |  |
| 押工組<br>Presser foot assy<br>(B257) | <br>S28129-101  | <br>S28132-101  | <br>S28134-101 | <br>S28136-101 |  |  |
| 針板<br>Needle plate                 | <br>S28083-001  | <br>S28084-001  | <br>S28085-001 | <br>S28086-001 |  |  |
| 主送り歯<br>Main feed dog              |  | <br>S28241-001 |   |   |  |  |
| 差動送り歯<br>Differential feed<br>dog  |  | <br>S28247-001 |   |   |  |  |

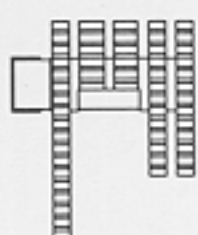
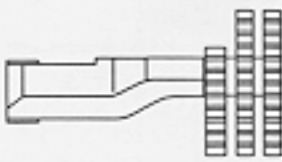
|                                    |   |   |   |   |  |  |
|------------------------------------|---|---|---|---|--|--|
| 機種<br>Model                        | B256<br>B257  | B256<br>B257  | B256<br>B257  | B256<br>B257  |  |  |
| 仕様<br>Specifications               | 0X6-2   | 0X6-3   | 0X6-7   | 0X6-8   |  |  |
| 仕様ラベル<br>Label                     | S08678-085  | S08678-086  | S08678-087  | S08678-088  |  |  |
| 用途<br>Application                  | ゴム入れヘム縫用(プーラ装置・定規開閉装置・左メス装置付)<br>Circular hemming (with puller, binder opener and left knife) |   |   |   |  |  |
|                                    | B256  | B257  | B256  | B257  |  |  |
|                                    |              |    |     |    |  |  |
| 針数(本)<br>No. of needles            | 2   | 2   | 3   | 3   |  |  |
| 針幅(mm)<br>Needle spacing           | 4.0   | 4.8   | 5.6   | 6.4   |  |  |
| 針止メ組<br>Needle clamp<br>assy       |            |  |  |  |  |  |
|                                    | S28772-001  | S28774-001  | S28782-001  | S28784-001  |  |  |
| 押工組<br>Presser foot assy<br>(B256) |            |  |  |  |  |  |
|                                    | S28751-101  | S28753-101  | S28755-101  | S28757-101  |  |  |
| 押工組<br>Presser foot assy<br>(B257) |            |  |  |  |  |  |
|                                    | S28571-101  | S28573-101  | S28575-101  | S28577-101  |  |  |
| 針板<br>Needle plate                 |            |  |  |  |  |  |
|                                    | S28083-001  | S28084-001  | S28085-001  | S28086-001  |  |  |
| 主送り歯<br>Main feed dog              |           |   |   |   |  |  |
|                                    | S28241-001  |   |   |   |  |  |
| 差動送り歯<br>Differential feed<br>dog  |           |   |   |   |  |  |
|                                    | S28247-001  |   |   |   |  |  |